

This is just a blank page instead of the cover page....

Table of Contents

Welcome to POF-USA.....2

STATE BY STATE WARNINGS3

FIREARM SAFETY RULES6

BREAK-IN PROCEDURES7

GENERAL OPERATION8

 OPERATION OF SAFETY.....8

 OPERATION OF BOLT CATCH.....9

 AMMUNITION11

 MAGAZINES.....12

 LOADING12

 INSERTING12

 REMOVING12

 LOAD AND FIRE WITH MAGAZINE13

 LOAD AND FIRE WITHOUT MAGAZINE14

 UNLOAD15

 TO RELOAD THE FIREARM.....15

 EXTRACT AND EJECT A CHAMBERED CARTRIDGE15

 REMOVE A BORE OBSTRUCTION.....16

 CLEAR A MALFUNCTION17

 MINIMIZE MALFUNCTIONS.....18

DISASSEMBLY19

REASSEMBLY20

 BOLT CARRIER GROUP21

 ADJUSTING THE GAS BLOCK PRESSURE - 5Position Gas Block.....22

 MODULAR HAND GUARD P-415 &P-30823

 MAGPUL MOE HANDGUARD.....23

 RENEGADE HANDGUARD24

 GAS BLOCK TUNING INSTRUCTIONS.....25

CARE AND CLEANING.....27

WARRANTY POLICIES28

DIAGRAMS28



Welcome to POF-USA

Patriot Ordnance Factory, Inc. (POF-USA) is an American owned and operated small business with facilities headquartered in Phoenix, Arizona. All POF-USA firearms are American made. POF-USA firearms are engineered and tested to assure they meet the highest standards for durability and performance. Read this manual in its entirety before attempting to operate your POF-USA firearm. In addition, POF-USA recommends that you receive proper training in the handling of firearms prior to handling any firearm.



WARNING



Please read the instructions and warnings contained in this manual BEFORE attempting to handle, load or utilize the POF-USA family of firearms. Even if you are familiar with the standard AR-10, AR-15, M-16, and/or M-4 family of firearms, you need to familiarize yourself with POF-USA firearms and their accessories before using them in any manner. Failure to do so could result in damage to the firearm, bodily injury to the shooter or bystanders, or even death.

The POF-USA firearms are designed for factory manufactured cartridges only. Using hand-loaded, remanufactured, reloaded, or other non-standard ammunition could result in serious malfunction, damage to the firearm, or serious bodily injury to the shooter or bystanders, or even death. POF-USA, Inc. is not liable for any damage to the weapon, bodily injury to person(s), or damage to any property resulting from the use or misuse of any firearm. This manual should accompany this firearm at all times. A replacement copy can be obtained anytime by visiting our website at www.pof-usa.com.

The safety warnings are for the protection of the owner and operator of this POF-USA firearm as well as the safety of others. Disregarding information in this manual or failure to follow the basic rules of safe firearms handling can result in property damage, bodily injury and even death.

- **Always wear eye and hearing protection**
- **Handle every firearm as if it were loaded**
- **Always keep the muzzle pointed in a safe direction**
- **Never chamber a round until you are ready to shoot**
- **Safety selector is on "SAFE" or engaged until ready to fire**

**PROTECT OUR CHILDREN
STORE YOUR FIREARMS RESPONSIBLY**



STATE BY STATE WARNINGS

Some states require by law that specified warning notices in “larger-than-normal” type be conspicuously included by the manufacturer, distributor, or retailer with firearms sold in that state. Since our products may be sold in those states we include the following:

California:



WARNING

“Children are attracted to and can operate firearms that can cause severe injuries or death. Prevent child access by always keeping guns locked away and unloaded when not in use. If you keep a loaded firearm where a child obtains and improperly uses it, you may be fined or sent to prison.”



ADVERTENCIA

“Los niños se sienten atraídos y se puede operar las armas de fuego que pueden causar lesiones graves o la muerte. Evitar el acceso niño siempre manteniendo las armas bajo llave y descargadas cuando no esté en uso. Si usted mantiene un arma de fuego cargada en que un niño obtiene y utiliza inadecuadamente, usted puede recibir una multa de enviado a la cárcel”.

Connecticut:

“UNLAWFUL STORAGE OF A LOADED FIREARM MAY RESULT IN IMPRISONMENT OR FINE”

Florida:

“IT IS UNLAWFUL, AND PUNISHABLE BY IMPRISONMENT AND FINE, FOR ANY ADULT TO STORE OR LEAVE A FIREARM IN ANY PLACE WITHIN THE REACH OR EASY ACCESS OF A MINOR UNDER 18 YEARS OF AGE OR TO KNOWINGLY SELL OR OTHERWISE TRANSFER OWNERSHIP OR POSSESSION OF A FIREARM TO A MINOR OR A PERSON OF UNSOUND MIND”

Maine:

“ENDANGERING THE WELFARE OF A CHILD IS A CRIME. IF YOU LEAVE A FIREARM AND AMMUNITION WITHIN EASY ACCESS OF A CHILD, YOU MAY BE SUBJECT TO FINE, IMPRISONMENT OR BOTH. KEEP FIREARMS AND AMMUNITION SEPARATE. KEEP FIREARMS AND AMMUNITION LOCKED UP. USE TRIGGER LOCKS.”

Maryland:

“WARNING: Children can operate firearms which may cause death or serious injury. It is a crime to store or leave a loaded firearm in any location where an individual knew or should have known that an unsupervised minor would gain access to the firearm. Store your firearm responsibly!”

Massachusetts:

“WARNING FROM THE MASSACHUSETTS ATTORNEY GENERAL: This handgun is not equipped with a device that fully blocks use by unauthorized users. More than 200,000 firearms like this are stolen from their owners every year in the United States. In addition, there are more than a thousand suicides each year by younger children and teenagers who get access to firearms. Hundreds more die from accidental discharge. It is likely that many more children sustain serious wounds, or inflict such wounds accidentally on others. In order to limit the chance of such misuse, it is imperative that you keep this weapon locked in a secure place and take steps necessary to limit the possibility of theft or accident. Failure to take reasonable preventive steps may result in innocent lives being lost, and in some circumstances may result in your liability for these deaths.”

“IT IS UNLAWFUL TO STORE OR KEEP A FIREARM, RIFLE, SHOTGUN, OR MACHINE GUN, IN ANY PLACE UNLESS THAT WEAPON IS EQUIPPED WITH A TAMPER-RESISTANT SAFETY DEVICE OR IS STORED OR KEPT IN A SECURLY LOCKED CONTAINER.”

New Jersey:

“IT IS A CRIMINAL OFFENSE TO LEAVE A LOADED FIREARM WITHIN EASY ACCESS OF A MINOR.”



North Carolina:

“IT IS UNLAWFUL TO STORE OR LEAVE A FIREARM THAT CAN BE DISCHARGED IN A MANNER THAT A REASONABLE PERSON SHOULD KNOW IS ACCESSIBLE TO A MINOR.”

Texas:

“IT IS UNLAWFUL TO STORE, TRANSPORT, OR ABANDON AN UNSECURED FIREARM IN A PLACE WHERE CHILDREN ARE LIKELY TO BE AND CAN OBTAIN ACCESS TO THE FIREARM.”

Wisconsin:

“IF YOU LEAVE A LOADED FIREARM WITHIN THE REACH OR EASY ACCESS OF A CHILD YOU MAY BE FINED OR IMPRISONED OR BOTH IF THE CHILD IMPROPERLY DISCHARGES, POSSESSES, OR EXIBITS THE FIREARM.”

As a responsible firearm owner it is your responsibility to be aware of any local, state, or federal laws governing the lawful ownership of firearms. The above is not all inclusive of all states and is subject to change. Please check with your local retailer, state police, and local law enforcement for current regulations in your area.

Visit the NRA website (www.nra.org) or the BATFE website (www.atf.gov) for further information.



FIREARM SAFETY RULES

1. **Treat all firearms as if they are loaded.** Always assume that a firearm is loaded even if you think it is unloaded. Every time a firearm is handled, for any reason, check to see that it is unloaded. If you are unable to check a firearm to see if it is unloaded, leave it alone and seek help from someone more knowledgeable about firearms.
2. **Keep the firearm pointed in the safest possible direction.** Always be aware of where a firearm is pointing. A "safe direction" is one where an accidental discharge of the firearm will not cause injury or damage. Only point a firearm at an object you intend to shoot. Never point a firearm toward yourself or another person.
3. **Keep your finger off the trigger until you are ready to shoot.** Always keep your finger off the trigger and outside the trigger guard until you are ready to shoot. Even though it may be comfortable to rest your finger on the trigger, it also is unsafe. If you are moving around with your finger on the trigger and stumble or fall, you could inadvertently pull the trigger. Sudden loud noises or movements can result in an accidental discharge because there is a natural tendency to tighten the muscles when startled. The trigger is for firing and the handle is for handling.
4. **Know your target, its surroundings and beyond.** Check that the areas in front of and behind your target are safe before shooting. Be aware that if the bullet misses or completely passes through the target, it could strike a person or object. Identify the target and make sure it is what you intend to shoot. If you are in doubt, DON'T SHOOT! Never fire at a target that is only a movement, color, sound or unidentifiable shape. Be aware of all the people around you before you shoot.
5. **Know how to properly operate your firearm.** It is important to become thoroughly familiar with your firearm. You should know its mechanical characteristics including how to properly load, unload and clear a malfunction from your firearm. Obviously, not all firearms are mechanically the same. Never assume that what applies to one make or model is exactly applicable to another. You should direct questions regarding the operation of your firearm to your firearms dealer, or contact the manufacturer directly.
6. **Store your firearm safely and securely to prevent unauthorized use.** Firearms and ammunition should be stored separately. When the firearm is not in your hands, you must still think of safety. Use a safety device on the firearm, such as a trigger lock or cable lock, so it cannot be fired. Store it unloaded in a locked container, such as a lock box or a firearm safe. Store your firearm in a different location than the ammunition. For maximum safety, you should use both a locking device and a storage container.
7. **Never use Alcohol, Over-The-Counter, Prescription, or other drugs before or while shooting.** These substances are likely to impair normal mental or physical bodily functions and must not be used before or while handling or shooting firearms.



BREAK-IN PROCEDURES

Please read "Breaking In Your New Weapon" and watch the video under "Cleaning Procedures" both of which can be found on our technical page. Make sure you clean and lube your weapon using the techniques shown in the video, especially the cleaning of the chamber (chamber brush attached to a drill).

Breaking In Your New Weapon

1. Thoroughly clean the chamber of your new weapon, and clean after every shooting session. Check out our links on the technical page for cleaning procedures and tips
<http://pof-usa.com/support/> & <https://youtu.be/AGQ-4avqHqA>
2. Generously lube the bolt carrier group (BCG) with your favorite firearm lubricant. As your weapon breaks in less lubrication will be needed and after a few hundred rounds just a light wipe will be sufficient.
3. Put a little lubricant in the buffer tube.
4. Never use lubrication in your gas system. The gas system should always be run without lubricant. You can clean the gas block the same as you would your barrel, just make sure you wipe it dry afterwards.
5. There is no break-in required for the barrel, just clean it at the end of each shooting session.
6. POF-USA only recommends the use of factory new ammo, and cannot offer you advice or tips regarding hand loading or re-loaded ammo.



GENERAL OPERATION

OPERATION OF SAFETY

The manual safety mechanism is located above the trigger on the left side (and right if ambidextrous equipped) of the lower receiver. The safety can be moved to “SAFE” anytime the hammer is cocked. When the safety is on, it blocks the trigger. The safety should always be kept in “SAFE” mode when loading or unloading the firearm and should be kept in “SAFE” mode at all times unless actually firing the firearm. Firearms are in the “SAFE” position when the lever is in a horizontal position. **(See Figures 1 & 2 below).**



Figure 1
“SAFE”



Figure 2
“FIRE”

Keep the safety on unless actually firing. Always move the safety fully to its intended position and check it. The safety is not “ON” unless it is completely “ON”. Never depend on a safety mechanism or any mechanical device to justify careless handling or permitting the firearm to point in an unsafe direction. The only “safe” firearm is one in which the bolt is open, the chamber is empty, and there is no magazine in the gun.

KNOW HOW TO USE THE SAFETY

OPERATION OF BOLT CATCH

POF-USA firearms are designed so that the bolt will remain open after the last shot has been fired, provided there is a magazine in the firearm. When the magazine is empty, the magazine follower engages the bolt catch, which retains the bolt carrier group (BCG), in the rearward position.

***WARNING: The bolt catch is NOT a safety device. It should not be used to hold back the bolt when there are cartridges in the magazine. A slight jar to the butt end of the firearm can cause the bolt catch to disengage and to feed a cartridge into the chamber.**

*The bolt catch should be used to hold the bolt in its rearward position only when the chamber is empty and an empty magazine is in place. The bolt catch is there for convenience when changing magazines.

To hold the carrier open:

1. Put safety on "SAFE".
2. Pull the charging handle all the way to the rear.
3. Depress the bottom part of the bolt catch plunger and allow the bolt carrier to move forward until it stops. **(See Figure 3)**
4. Newer P-308's and P-415's can also engage the bolt catch by pushing upward on the "button" inside the trigger guard. **(See Figure 4)**



Figure 3



Figure 4

To release the bolt carrier, allowing the bolt to move forward, KEEP SELECTOR ON SAFE and either:

1. Remove the magazine; draw the charging handle to the rear and release. Allow the handle to spring forward freely. Do not “ride” the charging handle or otherwise retard the forward motion.
2. Push the top part of the bolt catch toward the lower receiver and the bolt carrier will release. **(See Figure 5)**
3. On P-308's and P-415's, you also depress the bolt release lever on the right side of the firearm. **(See Figure 6)**



Figure 5



Figure 6

CAUTION: Bolt carrier is under heavy spring tension and can injure fingers when it slams shut.

AMMUNITION

POF-USA only recommends the use of factory new ammunition loaded in accordance with U.S. industry practice, and cannot offer any advice or tips regarding hand loaded or reloaded ammunition. Damages due to high pressure, reloaded, or non-standard ammunition is not covered under warranty.

Death, serious injury and damage can result from the use of wrong ammunition; bore obstructions, powder overloads, or incorrect cartridge components. Always wear eye protection and hearing protection.

**ONLY USE
FACTORY
AMMUNITION
LOADED TO U.S.
INDUSTRY
STANDARDS**

POF-USA SPECIFICALLY DISCLAIMS ANY RESPONSIBILITY FOR ANY DAMAGE OR INJURY WHATSOEVER OCCURRING IN CONNECTION WITH, OR AS A RESULT OF, THE USE IN POF-USA FIREARMS OF FAULTY, OR NON-STANDARD, OR "REMANUFACTURED", OR HAND LOADED (RELOADED) AMMUNITION, OR OF CARTRIDGES OTHER THAN THOSE FOR WHICH THE FIREARM WAS ORIGINALLY CHAMBERED

WARNING-LEAD EXPOSURE

Discharging firearms in poorly ventilated areas, cleaning firearms, or handling ammunition may result in exposure to lead and other substances known to the State of California to cause birth defects, reproductive harm, and other serious physical injury. Wash hands thoroughly after exposure.

SHOOTING OR CLEANING GUNS MAY EXPOSE YOU TO LEAD

MAGAZINES

- ❖ 5.56/.223 caliber firearms are normally supplied with one 30 round magazine.
- ❖ 7.62x51/.308 caliber firearms are normally supplied with one 20 round magazines.
- ❖ 7.62x39 caliber firearms are normally supplied with one 28 round magazine

Firearms supplied to states with magazine restrictions are shipped with the appropriate magazine

DAMAGED, NON-STANDARD, OR IMPROPERLY ASSEMBLED MAGAZINES

SHOULD NOT BE USED – THEY CAN CAUSE THE FIREARM TO MALFUNCTION

based upon the state restriction.

LOADING

Use only clean, dry ammunition of the proper caliber manufactured to U.S. Industry specifications, in good condition. With the short end of the magazine facing forward, place a round between the lips of the magazine with the bullet forward. Press the round down until it is held by the magazine lips. Place the next round and repeat until the desired number of cartridges are loaded.



INSERTING

The magazine may be inserted with the bolt carrier either closed or open (see OPERATION OF BOLT CATCH Page 9). More force will be required to insert the magazine with the bolt in the closed position in order to overcome the bolt carrier group.

1. Hold the magazine as shown and insert it into the magazine well until it is seated/latched.
2. Check to assure it is securely latched in place by pulling on the magazine, it should not come out.



REMOVING

To remove the magazine, push the magazine catch button towards the lower receiver from the right side (See Figure 7) or the magazine release lever from the left side on ambidextrous models (See Figure 8) until the magazine drops out of the magazine well. Avoid letting the magazine drop to

the ground, this will prevent the possibility of damage to the magazine and minimize the possibility of magazine related malfunctions.



Figure 7



Figure 8

LOAD AND FIRE WITH MAGAZINE

Safe firearm handling should be practiced with an unloaded firearm until you can perform each of the following steps with skill and confidence. Please read this manual completely prior to operating your POF-USA firearm.

1. Be certain the muzzle is pointed in a safe direction.
2. Verify the gas plug is set for "NORMAL" (see ADJUSTING THE GAS BLOCK PRESSURE Page 22).
3. Before inserting a loaded magazine, engage the bolt catch so that the bolt carrier is held open. Verify the chamber is empty. Move the safety selector to the "ON" or "SAFE" position.
4. Insert a loaded magazine into the magazine well and release the bolt catch by either depressing the pad on the left side or the lever on the right side. A cartridge will be stripped from the magazine and chambered by the motion of the bolt carrier moving forward.

WARNING: If cartridges do not feed smoothly from the magazine into the chamber then do not use the firearm until the problem is corrected (See CLEAR A MALFUNCTION, Page 17)

5. The firearm is now cocked and a cartridge is chambered. Visually check to be certain the safety is in the "ON" or the "SAFE" position, and the firearm is pointed in a safe direction.
6. When you are ready to fire, move the safety to the "FIRE" position.

WARNING: DO NOT TOUCH THE TRIGGER UNTIL YOU ARE ACTUALLY READY TO FIRE.

KEEP THE SAFETY "ON" UNLESS ACTUALLY FIRING

7. The firearm will fire one shot each time the trigger is pulled until the magazine is empty. Some of the gas produced by the combustion of the powder in the cartridge is used to drive the piston rearward; the piston drives the op-rod which in turn cycles the bolt carrier. This process ejects the fired cartridge case, re-cocks the firearm and loads a new cartridge from the magazine into the chamber.
8. Immediately following the firing of the shot and if no other shots are to be fired, put the safety in the "SAFE" position while the firearm is still pointed in a safe direction. The safety should always be moved to the "SAFE" position as soon as firing is completed, and it should be on "SAFE" at all times except when the firearm is on target and being fired.
9. When the last cartridge in the magazine has been fired, the bolt catch will automatically engage and hold the bolt carrier in the rearward open position.

IF DROPPED OR STRUCK WITH THE SAFETY "OFF", THE FIREARM MAY FIRE.

KEEP THE CHAMBER EMPTY UNLESS ACTUALLY FIRING!

KEEP THE SAFETY ON THE "SAFE" POSITION UNLESS ACTUALLY FIRING!

ANY GUN MAY FIRE IF DROPPED

LOAD AND FIRE WITHOUT MAGAZINE

Your firearm can be used as a single shot in the absence of a magazine or for training purposes. To do so, follow steps 1 & 2 above then manually load a cartridge into the chamber. Then follow steps 4 & 5 (disregard magazine). Note that the bolt will not automatically lock back after the cartridge is fired and ejected. Alternatively, the gas plug may be set to the "OFF" position as described in the section "ADJUSTING THE GAS BLOCK PRESSURE", however, the cartridge may be difficult to extract manually without the assistance of the gas system. Engage the safety between shots.



UNLOAD

WARNING: This sequence must be followed exactly as spelled out. Failure to do so can result in the rifle's chamber becoming unintentionally loaded with a cartridge!

1. Keep the muzzle pointed in a safe direction at all times and keep the fingers outside the trigger guard. Rotate the safety to the "SAFE" position.
2. Remove the magazine. **REMEMBER** that even though the magazine has been removed, a cartridge remaining in the chamber can still be fired!
3. Pull the charging handle all the way to the rear, extracting and ejecting the cartridge in the chamber.
4. When the bolt carrier is fully retracted, lock the bolt carrier back using the appropriate method laid out on page 9.
5. Always visually double check the chamber to be certain it is empty.
6. The only "safe" firearm is one in which the bolt carrier is open and the chamber and magazine are empty, and the muzzle is pointed in a safe direction.



TO RELOAD THE FIREARM

1. Firing all cartridges in the magazine and the chamber will cause the bolt carrier to automatically lock open. Keep the rifle pointed in a safe direction. Put the safety in the "SAFE" position. Removal of the magazine can be accomplished by pressing inward on the magazine catch button with the thumb or forefinger. The magazine will fall free of the rifle of its own weight. To avoid the possibility of damage to the magazine, do not let it fall to the ground.
2. Insert a loaded magazine. **WARNING:** The bolt catch is held in place by friction between the bolt face and the rear surface of the bolt catch. Therefore, when there is a loaded magazine in place and the rifle is jarred, the bolt can release and chamber a cartridge.
3. Release the bolt carrier by the methods described on page 10. A cartridge will be chambered when the bolt carrier shuts. **WARNING:** The rifle is ready for instant use once the bolt carrier moves forward. If the rifle is not to be fired immediately, keep the safety on "SAFE". When you are ready to fire, move the selector to the "FIRE" position and resume firing, putting the safety back on "SAFE" when you cease firing, even for a moment.

EXTRACT AND EJECT A CHAMBERED CARTRIDGE

When the rifle is fired, the same gas pressure that drives the bullet forward bleeds through the gas port to push the piston, op-rod, and bolt carrier to the rear. This action causes extraction and ejection of the fired cartridge case. If a cartridge fails to fire or if the shooter wishes to eject the chambered cartridge manually, follow the procedure described in "UNLOAD". When the charging handle is operated, there can be a failure to extract the cartridge from the chamber, or a failure to

eject the cartridge clear of the rifle. These failures usually are the result of the charging handle not being pulled rearward vigorously. From the foregoing, it is clear that the user must:

1. Always visually check the chamber after opening the action to eject a chambered cartridge. If the charging handle is not vigorously retracted, the extracted cartridge can be “ejected” into the magazine area.
 2. Thoroughly clean the chamber and the extractor as often as necessary. If an empty magazine is in the rifle when the charging handle is being retracted to extract a cartridge, the cartridge may drop on top of the magazine or remain held to the bolt face by the extractor. Then, when the bolt carrier goes forward, the cartridge will be chambered again!
- REMEMBER -- always remove the magazine before clearing the chamber, and visually check to ensure that no cartridges remain in the firearm.

REMOVE A BORE OBSTRUCTION

Firearms which are chambered for small caliber high-velocity cartridges are particularly susceptible to damage from firing when the bore is obstructed. Excess oil, grease, or water may form an obstruction which could cause damage and injury. If you suspect that your rifle may have excess oil, grease or other contaminants in the barrel. Or, if it may have been exposed to humid conditions, which could cause condensation, or to rain or snow, which might have entered the bore, open the bolt carrier and clean out the barrel. Inspect the bore visually to be sure that it is perfectly clear.

A firearm user should recognize that a lodged bullet is a fairly common form of bore obstruction. Therefore the following information on how a bullet may become lodged in the bore, and how it should be removed, deserves most careful reading and understanding!

1. When firing, a bullet may become lodged in the bore if the cartridge contains no powder, insufficient powder, or the powder fails to ignite and only the primer charge ignites, producing insufficient force to propel the bullet out of the bore.
2. A bullet may also become lodged in the bore when extracting a cartridge from the chamber (unloading). If the bullet is not crimped tightly enough in the cartridge case, the bullet may stick in the bore, with only the case being extracted.

Experience indicates that the two conditions described above occur most frequently with reloaded ammunition.

When either of the above described (1 or 2) situations occurs, proceed as follows *with the firearm pointing in a safe direction*:

- a. If the firearm is cocked, move the safety to the “SAFE” position.
- b. Remove the magazine from the firearm.
- c. Retract the charging handle and lock it in the open position. Retracting the charging handle should remove the cartridge case. Be certain the safety is in the “SAFE” position.
- d. Check the chamber to be certain there is no cartridge case in it – if there is, extract it before proceeding with steps (e) and (f).



- e. After making sure the chamber is clear and the magazine is removed, close the bolt, disengage the take down pin, remove the bolt and carrier and inspect the bore visually and with a rod as necessary.
- f. If the bore is obstructed, insert a proper size cleaning rod (without a tip or brush) into the bore from the muzzle and dislodge and remove the bullet. If the bullet does not readily dislodge, it may be necessary to lightly tap the handle end of the cleaning rod. If such efforts fail to dislodge the bullet, take the firearm to a gunsmith.
- g. Inspect the bore to be certain it is free of unburned powder particles or any other debris. At the same time clean the magazine, the magazine well, and other areas of the mechanism of unburned powder grains.

**DO NOT ATTEMPT TO REMOVE A LODGED BULLET USING A
BLANK CARTRIDGE OR A CARTRIDGE FROM WHICH THE BULLET HAS
BEEN REMOVED, OR BY ANY MEANS OTHER THAN THE USE OF THE
PROPER SIZE CLEANING ROD AND REASONABLE FORCE APPLIED TO THE ROD. BE
CERTAIN ALL LOOSE POWDER HAS BEEN REMOVED FROM THE BORE AND ACTION
BEFORE INTRODUCING THE ROD INTO THE BORE.
NEVER TRY TO SHOOT OUT A BORE OBSTRUCTION!**

**Always check the bore for an obstruction if you experience difficulty in
chambering a cartridge, experience a failure to extract, have a misfire, or the
firearm does not make a normal loud report on firing.**

CLEAR A MALFUNCTION

If you experience a malfunction, study the situation to determine the nature of the malfunction and how best to clear it. Any auto-loading firearm may occasionally malfunction. If it does:

1. Be certain the muzzle is pointed in a safe direction and the safety is in the "SAFE" mode.
2. When attempting to free a jammed cartridge, do not use any type of tool that is likely to act as a "firing pin" and discharge the cartridge should the tool impact on the primer. Never use a cartridge as a "tool."
3. After clearing a jam, inspect the firearm mechanism to determine if dirt or debris might be the cause of the problem. Excess lubricant or grease can cause cartridges to feed sluggishly. An accumulation of grease, dirt or powder grains in the magazine can contribute to cartridge feeding problems.
4. After clearing a jam, inspect all cartridges that have been removed from the firearm. Safely dispose of any cartridges which are dented or nicked or have bullets that are loose or improperly positioned in the cartridge case.



5. If it appears that the gun and magazine are not at fault and that the jam was caused by the type of cartridge being used, then try another type or brand of cartridge.
6. If the above procedures do not result in a smooth and reliable feeding firearm, do not use the firearm until it feeds cartridges smoothly and reliably. The firearm should be returned directly to POF-USA for repair. Contact TECHNICAL@POF-USA.COM for packing and shipping information.

Another precaution: Form the habit of examining fired cartridge cases from time to time. If fired cases have bulged heads or show splits on any part of the case, stop using that ammunition. If the problem persists with different types of ammunition contact TECHNICAL@POF-USA.COM.

7. If a cartridge or shell is caught between the bolt carrier and receiver, put the safety on "SAFE", retract the bolt carrier using the charging handle, and lock it in the open position using the bolt catch. Remove the magazine; then remove the jammed case.
8. If a fired cartridge case is in the chamber, use a cleaning rod to knock it out.
9. If an unfired cartridge is stuck in the chamber, keep the muzzle pointed in a safe direction with the safety in the "SAFE" position. Close the bolt, disengage the take down pin, remove the bolt and carrier, and remove the unfired cartridge from the chamber end rather than trying to dislodge it with a cleaning rod inserted from the muzzle. Use a piece of 3/16" brass rod which has one end shaped like a screwdriver tip. Insert the tip in the extractor groove of the cartridge, use the face of the ejection port as a fulcrum and carefully pry out the cartridge. Be careful not to strike the primer area of the live cartridge! Vigorously brush-clean the chamber with solvent after clearing any jam involving the chamber.

MINIMIZE MALFUNCTIONS

Auto-loading firearms of all makes and types occasionally malfunction when a cartridge fails to feed from the magazine to the chamber, or when a cartridge (or fired case) fails to properly extract and eject. To minimize the possibility of such occurrences the gun user should:

1. Use ammunition of the correct caliber and type which is loaded to industry specifications. Avoid reloads, remanufactured cartridges, and cartridges that are dirty, corroded, or deformed.
2. Clean and lubricate the gun in accordance with the instructions in this manual and the instructional videos on the POF-USA website.
3. If the mechanism shows signs of not functioning correctly, or if a part is damaged or broken, do not use the firearm. Have it inspected and repaired.
4. Use only high-quality magazines and carefully load the magazine. Do not exceed the stated magazine capacity.
5. Do not "ride" the charging handle when chambering a cartridge from the magazine. The bolt carrier should be permitted to snap forward under the full force of the buffer spring. If a cartridge does not fully chamber, use the forward assist no more than twice to force the bolt carrier closed. If the cartridge is still not chambered completely, the round should be cleared as a jam.
6. To minimize the probability of an unfired cartridge being jammed should it "fall back" onto the magazine, remove the magazine *before* retracting the carrier. When extracting an unfired cartridge, tip the right side of the rifle towards the ground so that gravity will assist



the cartridge to fall clear of the ejection port. Always retract the charging handle briskly when extracting a live cartridge. Take care to see that a cartridge is not forcibly ejected against a surface where the primer might be set off.

DISASSEMBLY

1. With the rifle pointing in a safe direction, safety in the "SAFE" position, remove the magazine by pushing the magazine catch button inward to release the magazine, while drawing magazine down.
2. Pull the charging handle all the way to the rear and push and hold the bottom tab of the bolt catch and release the charging handle. Make sure safety is in the "SAFE" position.

NOTE: Hammer must be cocked to place the selector in the "SAFE" position. Again, be sure chamber is empty!

3. On the left-hand side of the lower receiver push the rear take down pin to the right. From the right side of the rifle, pull the pin outward until the detent stops any additional travel.



4. Tip the upper receiver forward on the front pivot pin, remove the bolt carrier and charging handle from the upper receiver.

5. If desired, remove the upper receiver from the lower receiver by pushing the pivot pin on the left side of the lower receiver to the right. Reach to the right hand side of the lower receiver and pull the pivot pin to the right until the detent stops any additional travel.

6. Lift the upper receiver off of the lower receiver.



7. **Piston Models**

Push the gas plug pin from left to right until the detent stops any additional travel. Remove the gas plug by rotating until the flat side is facing the top of the gas block.

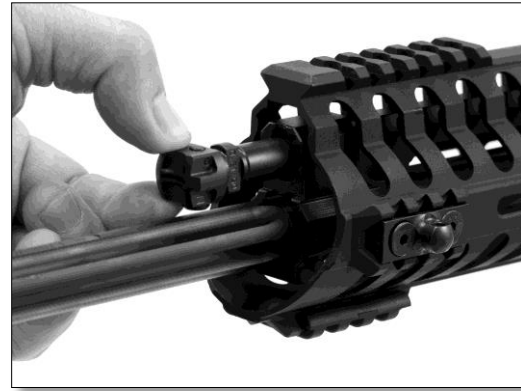

Removal of the gas block assembly is not advisable. The gas block assembly is factory fitted using special fixtures and tools. Attempting to fit the gas block assembly without the required special equipment can result in damage to the components and malfunctioning of the rifle. Removal/replacement or service of the gas block assembly must be performed by the factory.

REASSEMBLY

Again Be Sure Firearm and Magazines are Completely Unloaded!

1. Reassemble the charging handle and bolt carrier into the upper receiver:

- a. Turn the upper receiver upside down so that the top of the rifle is pointing toward the ground.
- b. Install the charging handle with the pickup lug pointing up.
- c. Put the charging handle into the upper, line up the locator tabs with the corresponding cut in the upper and drop the charging handle into the charging hand slot.
- d. Turn the bolt carrier upside down and, **making sure the bolt is fully forward**, place the key of the bolt carrier in channel of the charging handle, then push both the bolt carrier and the charging handle forward until the charging handle latch engages the upper receiver.

Care should be taken not to turn the upper receiver so that the bolt carrier can slide out the back of the upper receiver while the charging handle is unlocked. The bolt carrier will not fall out of the upper receiver as long as the charging handle is locked on the upper receiver.

2. Assemble the upper receiver to the lower receiver:

- a. Make sure the hammer is cocked, place the selector on "SAFE", and make sure both the take down pin and pivot pin are pushed completely to the right side of the lower receiver.

- b. Make sure the bolt carrier is all the way forward in the upper receiver.
 - c. Put the upper receiver onto the lower receiver and slide the upper receiver all the way rearward against the threaded section for the butt stock.
 - d. Push the pivot pin into the receiver until the detent locks in the hole in the pivot pin. Push the take down pin into the receiver until the detent locks in the hole in the take down pin.
 - e.
- 3. Install the gas plug:**
- a. Drop the op-rod and piston into the piston bore in the front of the gas block.
 - b. Push the gas plug into the gas block until seated.
 - c. Rotate the gas plug so its rim engages the gas block hook.
 - d. Push the gas plug detent all the way in and set the gas plug position to the desired setting (usually NORMAL).

BOLT CARRIER GROUP

Disassembly of the bolt carrier group:



1. Remove the firing pin retaining pin by pulling it through the left side of the carrier.



2. Remove the firing pin out the back of the bolt and bolt carrier.



3. The roller cam pin can now be removed from the bolt carrier group.



4. The bolt will slide out the front of the bolt carrier.

Reassemble the bolt carrier in reverse order of disassembly.

The bolt carrier group for the piston operated rifles is proprietary to POF-USA and is not interchangeable with other firearms.

ADJUSTING THE GAS BLOCK PRESSURE - 5Position Gas Block

The POF-USA gas piston operating system has an adjustable gas block that controls the amount of gas that is used to cycle the bolt carrier. The notched side of the gas plug denotes that it is in "NORMAL" mode when it is facing up. The rifle should cycle normally with most commercial ammunition. Depress the gas plug detent; rotate the gas plug 45° so the gas plug detent is facing

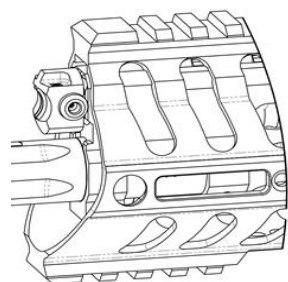

NORMAL –
NOTCH IS ON
TOP

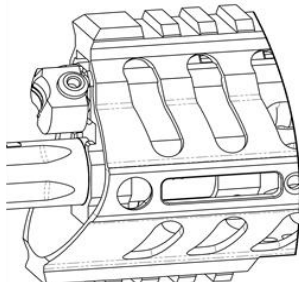

ADVERSE-
Reduced gas,
notch turned
45° to the
right

OFF –
BUTTON IS
ON TOP

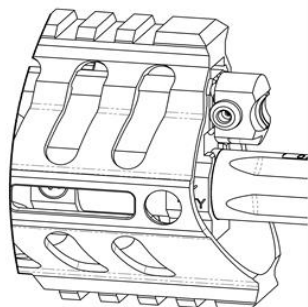
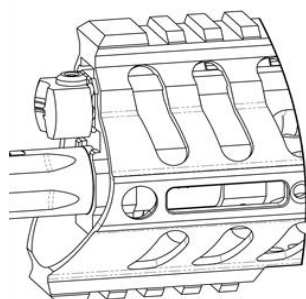

SUPPRESSED-
SMOOTH
SIDE IS ON
TOP

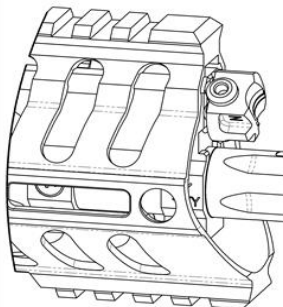

SUPPRESSED 2-
increased gas
smooth side turned
45° to the left

facing at a 45° angle, this denotes that the gas plug is in ADVERSE mode using less gas to compensate for some ammunition. Depressing the detent and rotating to the 90° position denotes that the gas plug is in "OFF" mode. This shuts off the gas from the gas block completely and causes the rifle to function as a single shot rifle. By depressing the gas plug detent and rotating the gas plug 180° from "NORMAL" mode, the smooth side of the gas plug is now facing up. The firearm is now in "SUPPRESSED" mode. Gas in this mode is restricted to compensate for the added backpressure from a suppressor. A second suppressed mode setting is available with an increased gas flow which may be required with some suppressors. Depress the gas plug detent and rotate the smooth face to a 45° angle, this denotes that the gas plug is in the SUPPRESSED2 mode.

MODULAR HAND GUARD P-415 & P-308

POF-USA's latest generation hand guard allows the operator to customize their hand guard with the desired rail section configuration. The modular hand guard comes with two picatinny rail sections already attached that can be moved to any position along the top, bottom, and sides of the hand guard. To install the rail sections, line up the rail section screw holes with the threaded holes on the hand guard and tighten the #10-32 countersunk screws to 25in/lbs. Do not over tighten the screws.

Over tightening can cause damage to the rail. For continuous picatinny railed sections along the hand guard, the rail sections can be overlapped together using the corresponding male and female ends. **Be sure that all screw holes are utilized when being attached. Do not attach the rails to the hand guard in a manner to where they will hang off the hand guard.**



The latest generation of M-Rail handguards are M-LOC compatible and have eliminated the use of a wedge block for installation. Instructions for removal and installation of older handguards can be found on the technical page of our website <http://pof-usa.com/support/>

MAGPUL MOE HANDGUARD



Pull down on the delta ring, and pull directly out on the bottom of the handguard. With the bottom of the handguard pulled away from the D-Ring, the front comes out without any effort. You can look at the front end of the handguard, and see where it interfaces with the handguard cap. Once the first half of the handguard is off, pull off the second one in the same manner.

Installation of the Magpul MOE Handguards is easiest by installing the top handguard first. Line up the upper piece with the handguard cap, and push it all the way forward, then pull down on the D-Ring and drop it into place. The bottom half of the MOE Handguard is pushed into the handguard cap, and with the D-Ring pulled down, it is secured once both sections are in position.



RENEGADE

FOREND INSTALLATION INSTRUCTIONS

The Renegade and Renegade Plus use a unique mounting and locking system for the handguard. The narrow profile handguard is slipped over the barrel nut and locked horizontally into place using two front sling mounts, one on the right side and one on the left side. Additionally, two screws located at the bottom of the handguard are tightened and effectively clamp the handguard into place

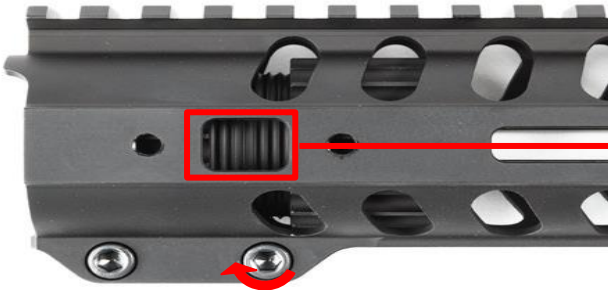

Once the handguard is slid into position the cutout in the barrel nut should be visible in the window of the handguard as shown here.

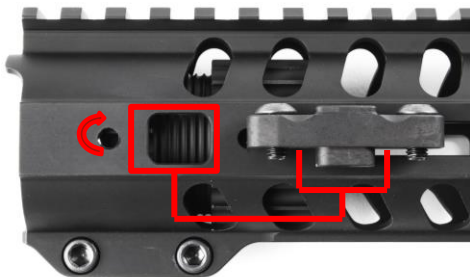

The square "block" on the sling mount will fit into the window of the handguard and "lock" into the barrel nut. Two screws are then tightened on the sling mount to **25 inch lbs**. This process is accomplished on both the right and left side of the weapon. The bottom two screws are also tightened to **25 inch lbs**.

RENEGADE

GAS BLOCK TUNING INSTRUCTIONS

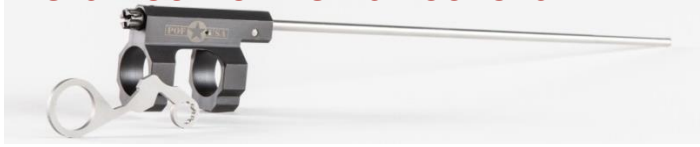

Tuning Instructions.

Note:

- This gas block will have a minimum of 9 positions, including the fully closed “off” positions. Your gas block may have 1 or 2 additional open positions.
 - By design, there are 3 different tools you might use to adjust your regulator. The first is the custom wrench provided with the gas block. It is designed with a finger loop that will also allow it to be attached to your key chain. It also is small enough for storage in many grips. The custom wrench has a unique shape, because it has been optimized for use with POF-USA handguards. However, it can be used if you have installed your Dictator™ with a handguard that does not extend past the gas block. The second method is a 3/32” hex wrench. The third is a flat head screwdriver.
1. Remove any magazines or ammunition feeding devices from the firearm and make sure the rifle is clear and unloaded.
 2. Turn the regulator in towards the gas block until it can no longer rotate. This is the “off” position. In this position, the gas will be completely blocked from entering the gas tube. In this setting, you will have to cycle the gun manually.
 3. Turn the regulator in the opposite direction as step 2. You should hear and/or feel a “click”. Each click is one position. Turn the regulator to the first click. You have slightly opened the gas port.
 4. Load one round in a magazine and insert it into your firearm. Following the rules of gun safety, fire the weapon.
 5. Observe whether the bolt carrier cycled back and was held open by the bolt catch. On the first position, it is not likely.
 6. Remove the magazine and clear the firearm.
 7. Repeat steps 3-5 to open the gas flow incrementally until the bolt carrier cycles back and is held open by the bolt catch.
 8. Remove the magazine and clear the firearm.
 9. Load a few rounds in the magazine and insert the magazine into your firearm. Following the rules of gun safety, fire the weapon consecutively and observe the ejection pattern of the brass. If the muzzle is 12 o’clock and the buttstock is 6 o’clock, you are looking to achieve consistent ejection at 3 o’clock.

10. If the ejection is somewhere between 6 o'clock and 3 o'clock, repeat the clearing, firing, observing, clearing, and adjusting cycle, until the ejection does reach 3 o'clock. Your rifle is set.
11. After shooting over time, you may notice your ejection becoming sluggish and moving back towards 6 o'clock. If this is the case, remove the magazine, clear the firearm, and turn the regulator to open the gas flow.

Maintenance and cleaning

After extended use, it may become difficult to adjust the regulator. Below are the instructions for disassembly and cleaning. Note: The included diagram may be referenced for part descriptions and information.

1. Remove any magazines or ammunition feeding devices from the firearm and make sure the rifle is clear and unloaded.
2. Using a drift pin punch, remove the Regulator Retaining Pin (Item 5) from the gas block.
3. Spray some carbon cleaner into the hole at the top at the top of the Gas Block (Item 1), and allow it to soak in. Liberal application may be required.
4. Using the custom POF-USA wrench, a flat screwdriver or 3/32" hex wrench, work the regulator (Item 4) back and forth to break up the carbon built up on the threads.
5. Using the custom POF-USA wrench, a flat screwdriver or 3/32" hex wrench, turn the regulator until it is completely unthreaded. If it will not completely unthread, repeat steps 3-4 until it will. Once you have passed the threads, the Regulator Detent Ball (Item 3), may engage them when attempting to remove the regulator from the gas block. If this occurs, it is recommended to continue "unthreading" the regulator until the threads have cleared the ball.
6. Remove the regulator from the gas block. Be aware of the location of the ball detent.
7. Remove the ball detent and store in a safe location.
8. The ball detent spring (item 2) will likely be held in place by force. For replacement purposes, please know that the spring is an AR15/M16 extractor spring. You may choose to remove it or not.
9. Spray carbon cleaner into the open bore. Scrub and flush out the built up carbon.
10. If you removed the ball detent spring, reinstall it. Push it all of the way down into the counter bore.
11. Place the ball detent into the pocket in the bore. It should rest in place.
12. Taking care not to displace the ball detent, carefully install the regulator. If there is resistance when the threads interact with the ball detent, "screw" the threads over the detent. When the threads on the regulator come into contact with the threads on the gas block, you may want to twist the regulator in the unthreading direction while lightly pressing it into the gas block. You should be able to feel the thread starts align. Screw the regulator all the way in.
13. Reinstall the regulator retaining pin.



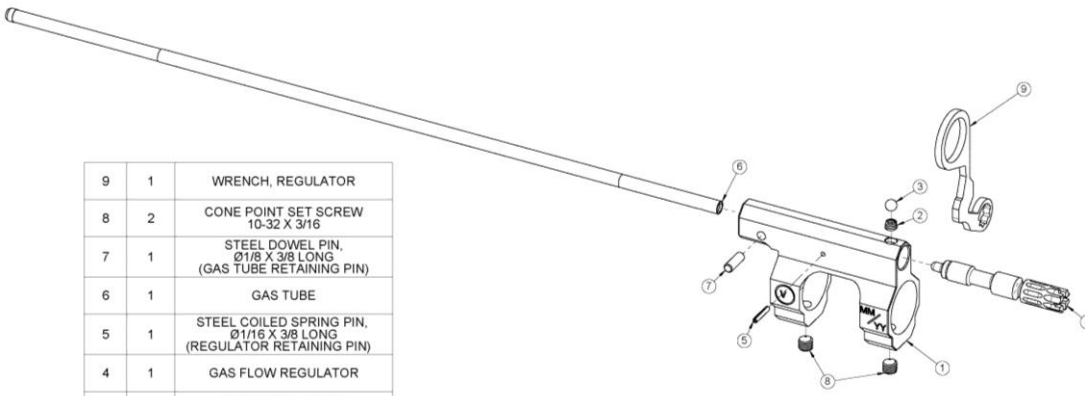

9	1	WRENCH, REGULATOR
8	2	CONE POINT SET SCREW 10-32 X 3/16
7	1	STEEL DOWEL PIN, Ø1/8 X 3/8 LONG (GAS TUBE RETAINING PIN)
6	1	GAS TUBE
5	1	STEEL COILED SPRING PIN, Ø1/16 X 3/8 LONG (REGULATOR RETAINING PIN)
4	1	GAS FLOW REGULATOR
3	1	STEEL BALL, Ø5/32 (REGULATOR DETENT)
2	1	AR15/M16 EXTRACTOR SPRING (DETENT SPRING)
1	1	GAS BLOCK
ITEM NO.	QTY REQ'D	DESCRIPTION

CARE AND CLEANING

After each shooting session, at regular intervals, or whenever your firearm has been exposed to sand, dust, extreme humidity, condensation, immersion in water, or other adverse conditions; disassemble, clean and lubricate using the techniques shown in the video that can be viewed either on YouTube or by going to the link on POF-USA's website:

<http://pof-usa.com/support/> or <http://pof-usa.com/category/videos/cleaning/>

Basic Procedures are:

1. Disassemble the firearm as described on pages 19-20.
2. Clean the barrel bore with patches and solvent using a cleaning rod.
3. Remove powder residue from all components and wipe with a clean cloth.
4. Only use a light application of oil on the riding surfaces of the bolt carrier group. Excessive oil will attract dust and dirt and may congeal in cold weather possibly interfering with the safe operation and reliable function of the firearm.

NEVER LUBRICATE THE PISTON SYSTEM

WARRANTY POLICIES

- ❖ All POF-USA firearms have a 100% satisfaction guarantee and have a limited lifetime warranty. POF-USA firearms are warranted against defects in material and workmanship for the life of the firearm regardless of ownership. Normal maintenance is not covered by the warranty and it is the responsibility of the owner to assure the weapon is properly maintained. All labor and /or replacement parts at the discretion of POF-USA are free of charge.
- ❖ **Shipping to and from our facilities, government fees, damages caused by failure to perform normal maintenance, sales outside the United States, damages due to high velocity, high pressure, reloaded, remanufactured, or other no non-standard ammunition, consequential or incidental damages and /or expenses, any unauthorized repair, modification, misuse, abuse, or alteration of the product is not covered by this warranty.**
- ❖ In order to help us assist you better, please register your firearm through our Warranty Registration online form at <http://pof-usa.com/warranty-registration/>
- ❖ For further technical assistance or to obtain warranty information on your POF-USA firearm, email technical support at TECHNICAL@POF-USA.COM

Altering or modifying parts is dangerous and will void the warranty. Your POF-USA firearm was manufactured to perform properly with the original parts as designed. It is your responsibility to make sure any parts you install are made for this firearm, installed correctly, and that neither the originals nor the replacement parts are altered or changed. Your POF-USA firearm is a complex precision tool with many parts that must operate correctly with other parts in order to maintain proper and safe operation. Putting your firearm together improperly or with incorrect or modified parts can result in a damaged firearm, serious personal injury, or death to you and/or others through malfunction. Always have a qualified armorer or gunsmith work on your POF-USA firearm systems or other firearms.

Diagrams

The Following parts diagrams are provided to help you identify individual parts in your firearm. Please use the following chart to identify the upper and lower for your model.

MODEL	UPPER	LOWER
P-415	P-415	P-415
P-308	P-308	P-308
Puritan	Puritan	P-15
Renegade	Renegade	P-15
Renegade Plus	Renegade Plus	P-415



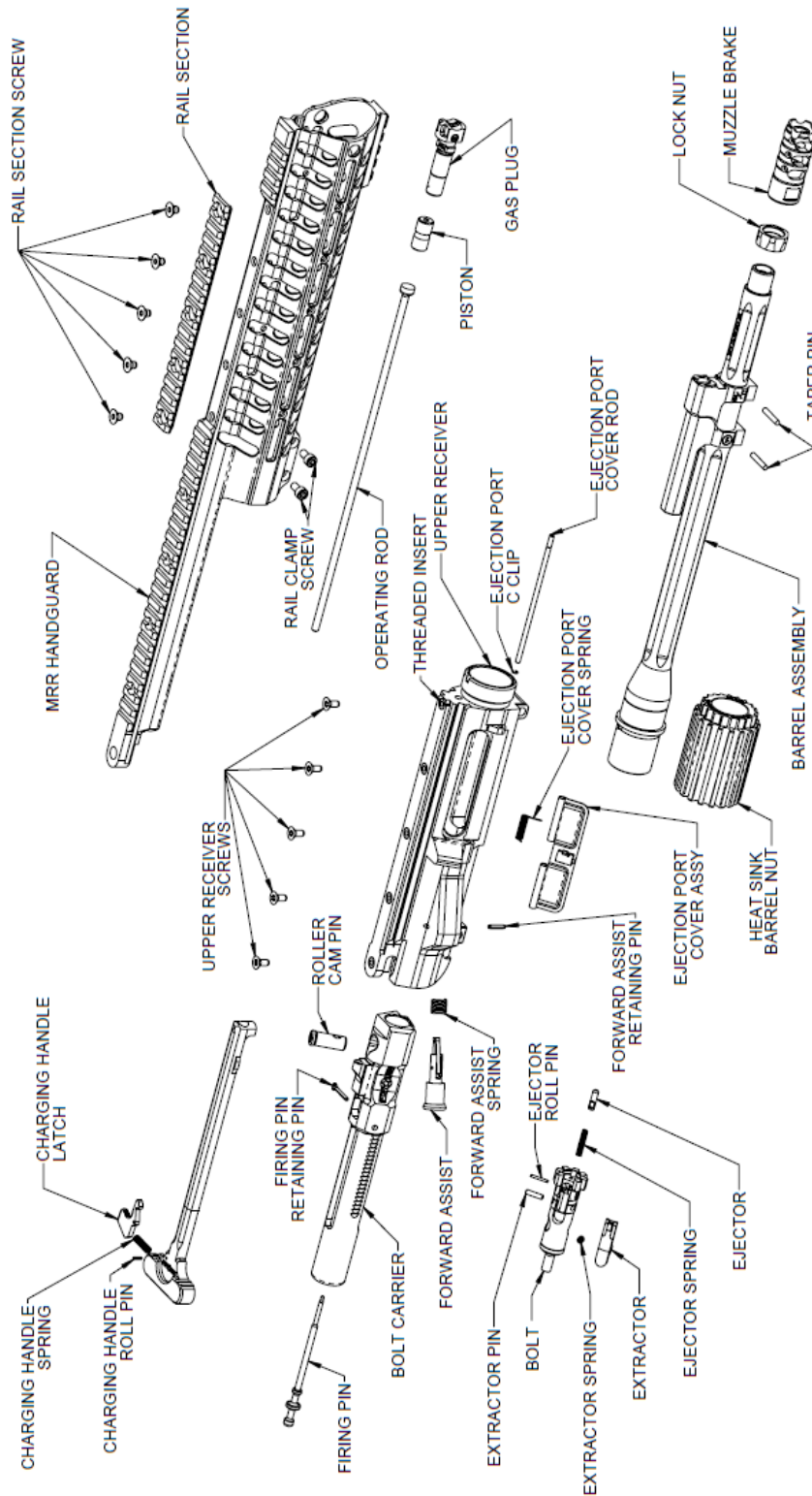

POF-USA GEN 4 P308 UPPER RECEIVER COMPONENTS BY DESCRIPTION

REV DATE: 10/29/2015



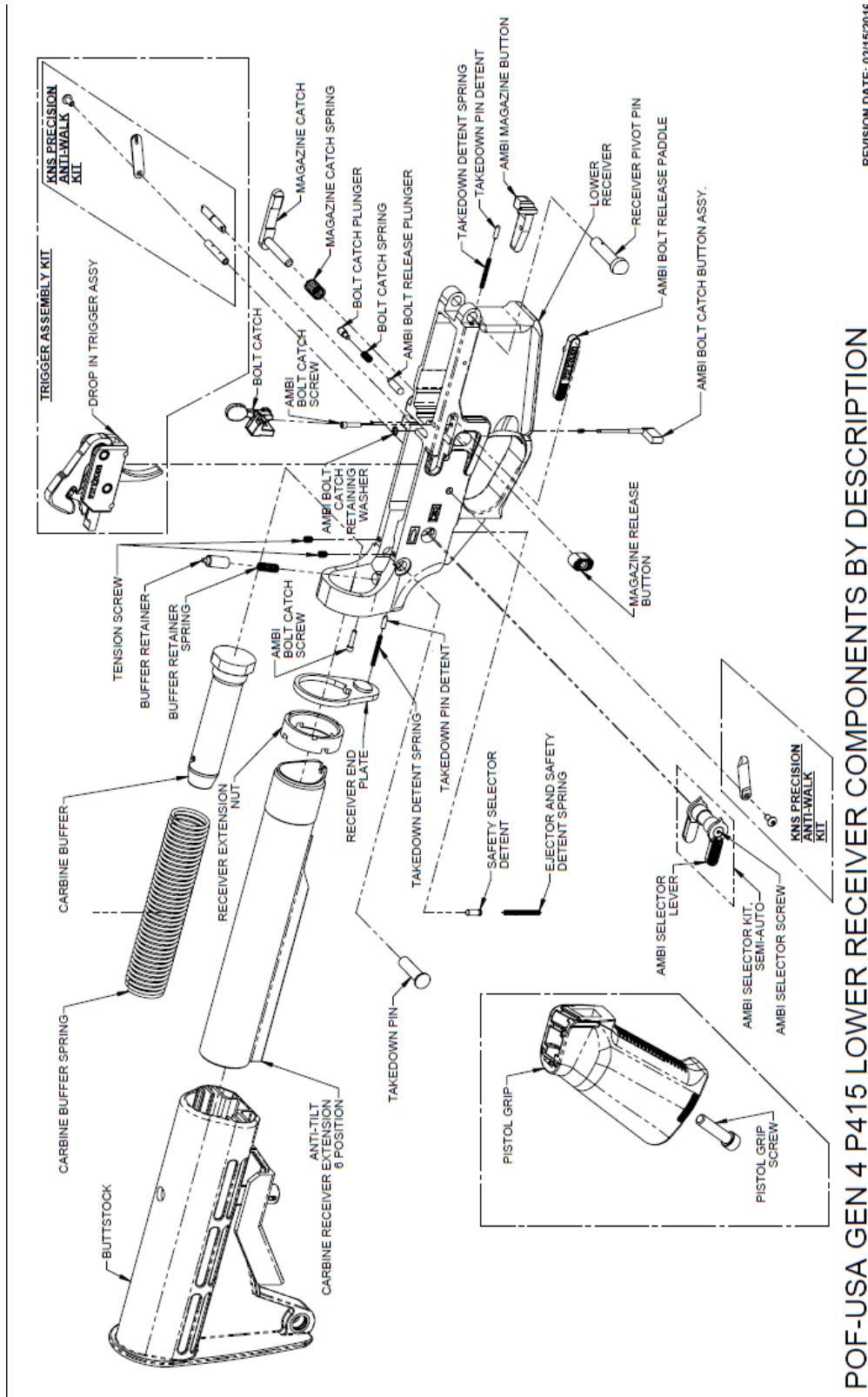

POF-USA GEN 4 P415 LOWER RECEIVER COMPONENTS BY DESCRIPTION

REVISION DATE: 03/15/2016



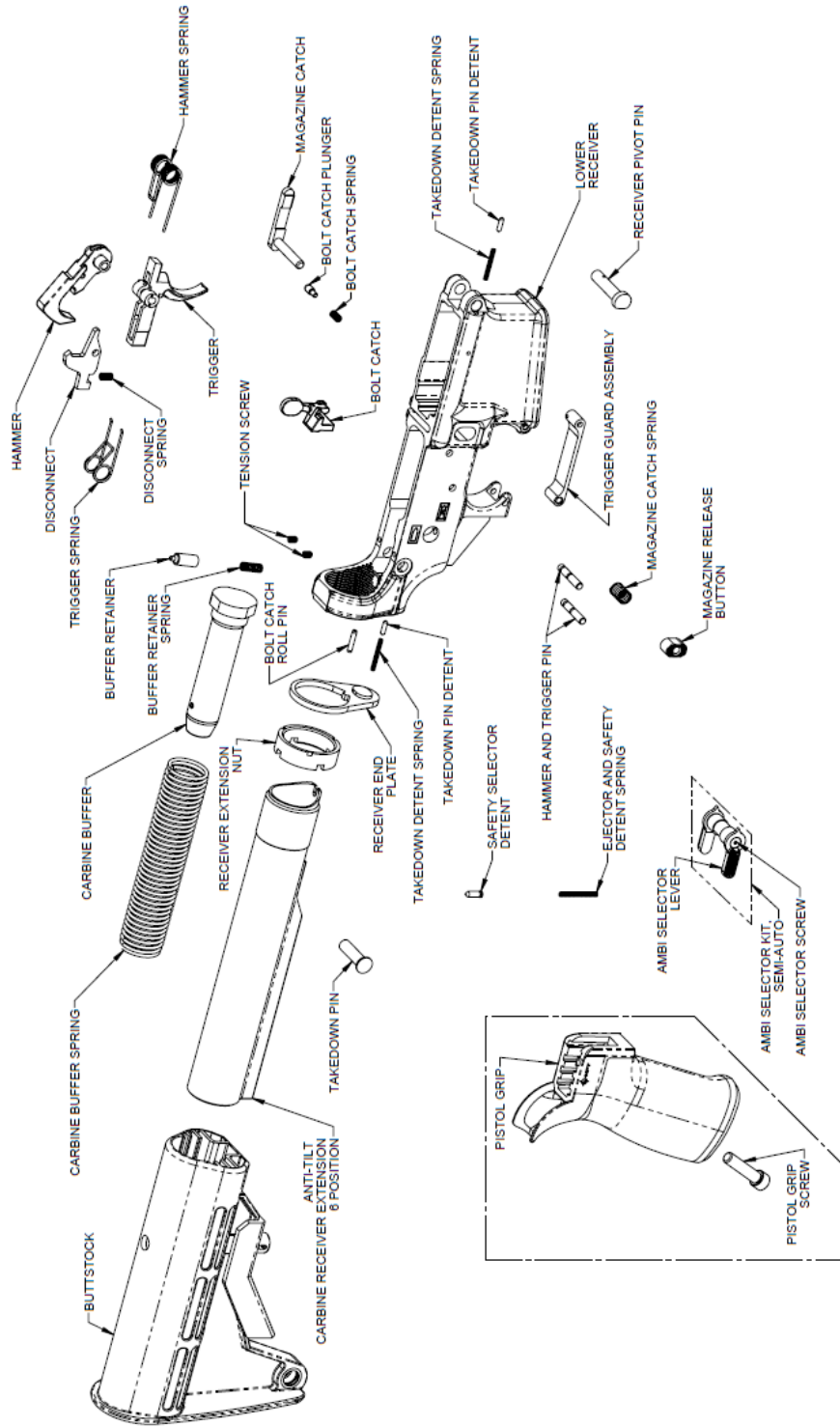

POF-USA P15 LOWER RECEIVER COMPONENTS BY DESCRIPTION

REVISION DATE: 03/18/2016



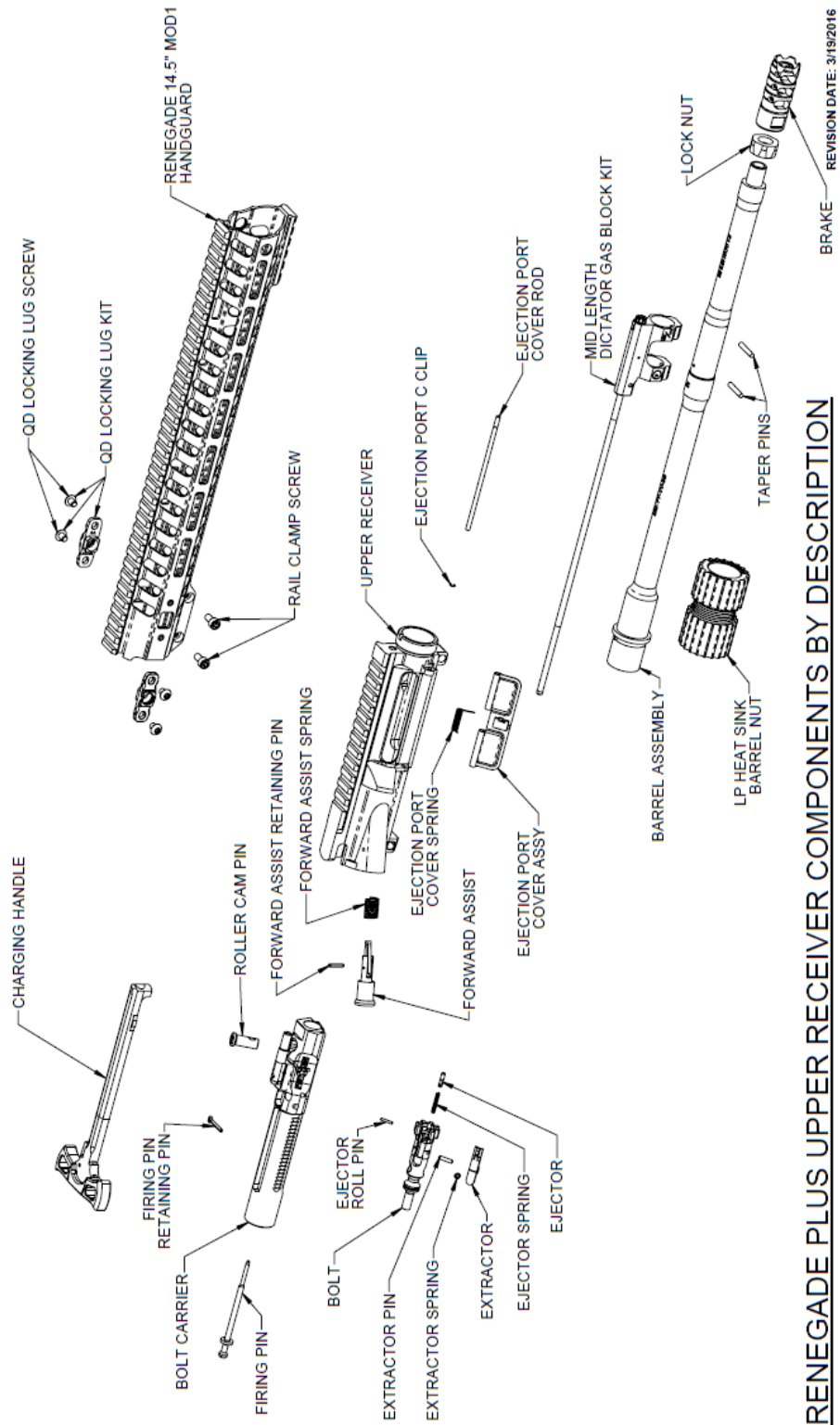

RENEGADE PLUS UPPER RECEIVER COMPONENTS BY DESCRIPTION

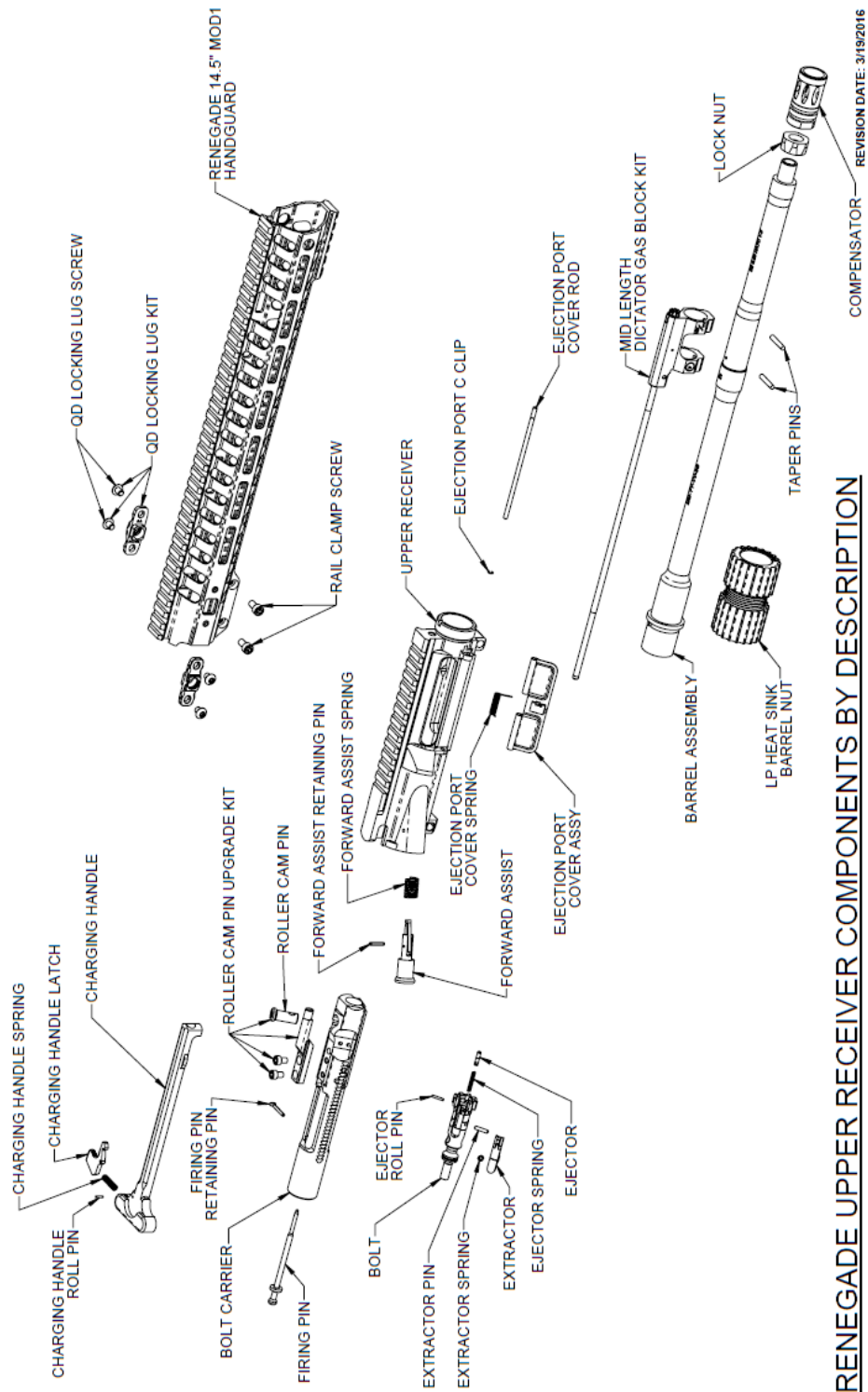

RENEGADE UPPER RECEIVER COMPONENTS BY DESCRIPTION



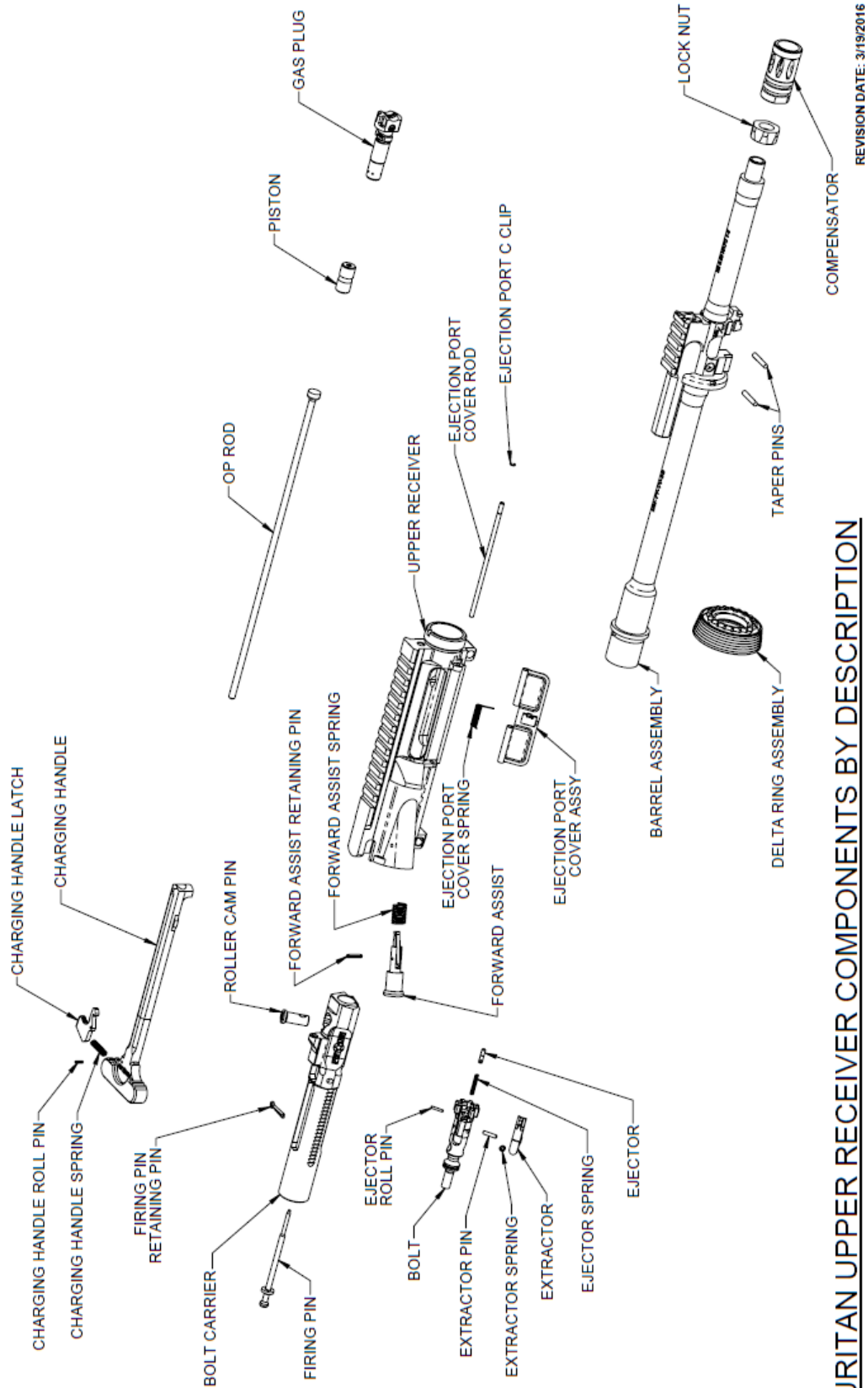

PURITAN UPPER RECEIVER COMPONENTS BY DESCRIPTION



