

USER MANUAL

Girsan Pistols



- **MC1911** (.45 ACP Single Action)
- **MC1911S** (.45 ACP Single Action)
- **MC1911C** (.45 ACP Single Action)



Come shoot the quality.

Zenith Firearms, an American importer of high quality firearms and accessories, is a proud distributor of GIRSAN firearms. GIRSAN is the producer of Yavuz 16 pistols which are used by Turkey's foremost civilian and official establishments.



WARNING

Please read this user manual carefully before using the firearm.

WARNING

Do not use this firearm until you fully understand all of the safety instructions and handling procedures.

NOTE

Should you require further information, please call a Zenith Firearms representative at 434.202.7790.



INDEX

1. GENERAL WARNINGS	4
2. SAFETY GUIDELINES	4
3. PRODUCT PRESENTATION AND SPECIFICATIONS	8
4. MAIN COMPONENTS	9
5. TECHNICAL SPECIFICATIONS.....	10
6. OPERATING SYSTEM.....	11
7. HOW TO USE THE PISTOL.....	12
8. MAINTENANCE AND CLEANING.....	17
9. TROUBLESHOOTING.....	23
10. EXPLODED DRAWINGS AND PART LIST	24
11. WARRANTY CERTIFICATE	27

1. GENERAL WARNINGS

- Read this user manual carefully before using the product.
- Do not use any firearm before reading the safety rules and maintenance instructions.
- Obey the laws in your country referring to firearms purchasing, carrying and use.

All firearms are dangerous. Zenith Firearms and GİRSAN are not responsible for any damage that results from the improper use of your firearm.

2. ESSENTIAL FIREARM SAFETY GUIDELINES

These firearm safety guidelines have been prepared by Zenith Firearms, based upon currently available information. They are provided to you as a courtesy and in the interest of furthering safety. These guidelines are not comprehensive, nor do they modify or replace rules, recommendations, standards, or regulations made by legal authorities or manufacturers.

As a responsible firearms supplier, Zenith believes that no issue is more important than firearm safety. We urge you to learn and practice the following guidelines and to make them your habit when handling firearms. This will help ensure safe handling of your firearm(s) and help prevent accidents. We also encourage you to complete an approved firearms safety-training course.

THE 3 CARDINAL FIREARMS SAFETY RULES

1. Always handle a firearm as if it is loaded

Even if you determine that a firearm is unloaded, always, always, always handle it like it IS loaded. When you handle a firearm, the first thing you should do (with the firearm pointed in a safe direction), is open the action to identify whether the firearm is loaded. If you do not know how to open the action, do not handle the firearm. And remember, removing a magazine alone does not make a firearm unloaded, as there may be a round in the chamber.

2. Always keep your finger out of the trigger guard and off the trigger until you are ready to shoot your target

Do not place your finger inside the trigger guard until you have placed a firearm's sights on your target and have decided to fire. The best place to rest your finger in the meantime is above the trigger guard along the frame. By waiting until you are aimed at your target, if the trigger were to be pressed, you will guarantee that a shot will travel safely in the direction of your intended target.

3. Always keep a firearm pointed in a safe direction, before and beyond your target

It is important to identify your actual target, but it is just as important to know what lies past and before your target. A safe direction is any direction where an unintentional discharge or miss will not cause injury or damage. In determining a safe direction, remember that a round can ricochet off an object like a floor, water or wall, or go through walls, floors, ceilings, and windows. Whether in a house or outdoors, the safest direction is the muzzle angled down toward the floor. And never point at or cross the muzzle of a firearm (loaded or unloaded) at any part of any person's body—the laser rule!

ADDITIONAL FIREARMS AND AMMUNITION RULES

ALWAYS KEEP CHILDREN AND OTHERS SAFE BY STORING FIREARMS SECURE AND AWAY FROM UNAUTHORIZED PERSONS

You should always store firearms and ammunition out of the sight and reach of children and anyone else who is not an intended user or not physically or mentally capable of handling and using them properly and safely. Store firearms in a safe storage place – ideally, one you can lock.

CAREFULLY READ THE ENTIRE INSTRUCTION MANUAL THAT COMES WITH YOUR FIREARM

You should only use a firearm if you fully understand how to safely operate it. All firearms come with an instruction manual created by the manufacturer. If the firearm does not come with an instruction manual, contact the manufacturer directly and request one.

ALWAYS DETERMINE THAT THE FIREARM IS SAFE TO OPERATE

Before shooting, make sure the firearm is in good working order, that the barrel is clear, and that the firearm is safe to operate. This is especially important when handling a firearm that has been stored or unused for a long period of time.

ALWAYS USE CORRECT AMMUNITION

Never use improper or incorrect ammunition. Only use ammunition that is recommended by the firearm manufacturer the caliber of your firearm. Most firearms have the caliber engraved or stamped on the barrel. Your ammunition should have the exact same caliber. If you use the incorrect ammunition, it can destroy a firearm and cause serious injury. Additionally, it voids your warranty.

WHEN CLEANING A FIREARM, MAKE SURE IT IS NOT LOADED

One of the most common statements following an accidental discharge is: “I was cleaning the firearm and it went off!” When you clean a firearm, make sure it is not loaded. You should keep the ammunition in another room until you have finished cleaning the firearm and are ready to reload.

NEVER USE FIREARMS WHILE USING DRUGS OR ALCOHOL

When you handle firearms, your judgment must NOT be impaired. You should NEVER handle firearms while under the influence of alcohol, illegal drugs or while using legal prescription medication that can make you tired or affect your senses, reflexes, or judgment.

USE EYE AND EAR PROTECTION

Always wear proper eye and ear protection while shooting firearms; ear protection will help prevent hearing loss from the extreme decibel level of gunfire, and eye protection will help prevent ejection gases, ricocheted objects, casings, or any foreign objects from damaging your eyes. Be smart, be safe.

3. PRODUCT PRESENTATION AND SPECIFICATIONS

Your pistol comes with the accessories listed below:

- Pistol
- 3 magazines
- User manual
- Cleaning and oiling supplies
- Pistol lock

GENERAL SPECS OF THE PISTOL

There are differences among the GİRSAN pistols, but this series all use a similar operating system.

Locking System: Most GİRSAN pistols are semi-automatic firearms operating on the short recoil principle. This action is provided by the slide moving to the rear and the barrel moving down once unlocked. The other system utilized is the recoil operated system where the barrel is fixed and the slide moves rearward once the barrel pressure drops.

Loaded Chamber Indicator: When a round is chambered, the extractor head protrudes further from the slide breech and exposes a red warning tab. In the dark, this protrusion can also be felt by touch. This makes it unnecessary to pull back the slide to verify if the chamber is loaded.

4. MAIN COMPONENTS

- ① Slide
- ② Frame (grip and trigger group)
- ③ Forged steel barrel
- ④ Slide stop
- ⑤ Recoil spring
- ⑥ Recoil spring plug
- ⑦ Barrel bushing
- ⑧ Recoil spring guide



5. TECHNICAL SPECIFICATIONS

MODELS	MC1911	MC1911S	MC1911C
Caliber	.45 ACP	.45 ACP	.45 ACP
Operating System	semi-automatic; single action; recoil operated		
Length	8.63 inches	8.74 inches	8.07 inches
Height	5.73 inches	5.73 inches	5.73 inches
Width	1.27 inches	1.27 inches	1.27 inches
Weight (without magazine)	38.4 ounces	38.4 ounces	36.7 ounces
Capacity	8 + 1	8 + 1	8 + 1
Full Magazine Weight	8.5 ounces	8.5 ounces	8.5 ounces
Barrel Length	5.03 inches	5.03 inches	4.21 inches
Barrel Production Method	cold forged steel	cold forged steel	cold forged steel
Barrel Life	30,000 rounds	30,000 rounds	30,000 rounds
Sight System	fixed sights	fixed sights	fixed sights
Sight Radius	6.2 inches	6.2 inches	5.53 inches
Safety System	safety lever, hammer safety, grip safety	safety lever, hammer safety, grip safety	safety lever, hammer safety, grip safety
Effective Range	180 feet (± 33 feet)	180 feet (± 33 feet)	180 feet (± 33 feet)
Muzzle Velocity	820 FPS	820 FPS	820 FPS
Trigger System	single action	single action	single action

6. OPERATING SYSTEM

GİRSAN 1911 pistols are semi-automatic, single-action pistols utilizing a recoil operation. Upon firing, the pressure developed by combustion gas in the chamber recoils the slide and barrel assembly together. After a short distance, a link allows the barrel to pivot, releasing the slide, letting it recoil while the barrel stops against the frame. During this rearward movement, the slide extracts and ejects the fired cartridge case, cocks the hammer and compresses the recoil spring. Under the force of the recoil spring, the slide then moves forward, feeding the next cartridge from the magazine into the chamber and causing the barrel-slide to lock. The slide stays open after the last cartridge in the magazine has been fired and ejected.



WARNING

Do not apply force to the pistol with any object while handling, cocking, disassembling or cleaning the pistol.

7. HOW TO USE THE PISTOL



WARNING

Keep your finger outside the trigger guard and off the trigger until you intend to fire.

BEFORE SHOOTING

- With the safety on, the pistol cannot fire. Set the safety lever “on” by sliding the lever up.
- Prior to use, be sure that the chamber is empty and the barrel is free from any obstructions (Picture 1).
- This pistol has a grip safety system. Therefore, the pistol cannot fire unless the safety is deactivated by the user holding the grip (Picture 2). This system provides additional safety to the pistol.

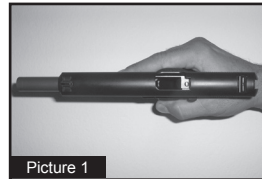

Picture 1

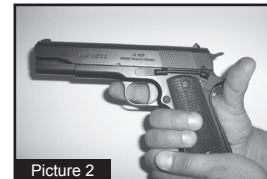

Picture 2



Picture 3

FUNCTION CHECKS

- Be sure that the pistol is unloaded and the magazine is empty before starting any function checks (Pictures 1, 3).

SLIDE AND BODY FRAME CHECKS

- Release the magazine (Picture 4) by pressing the magazine release button. Pull the slide all the way to the rear (Picture 5).
- While drawing the slide back, make sure the slide moves easily on the body frame and cocks the hammer. With the hammer cocked after you retract the slide, pull the trigger and check to ensure the hammer falls properly (Picture 6).
- After inserting an empty magazine, repeat the same action. The slide will stay locked and open in the rear position (Picture 7).

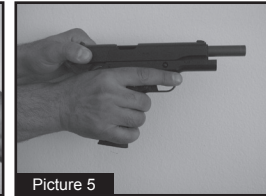

TRIGGER AND SAFETY LEVER CONTROLS

- After cocking the hammer, hold the pistol firmly, pull the trigger to check if the hammer falls making an audible click (Picture 8).
- The safety lever prevents the hammer from falling with the safety on. Pull the trigger and the hammer should not fall.
- The grip safety also prevents the pistol from firing. With the hammer cocked and the safety off, hold the pistol lightly so as not to squeeze the backstrap grip safety, and the pull the trigger. The hammer should not fall.

- The half-cock safety is designed so that while manually cocking the hammer, if it slips and falls forward, it cannot strike the firing pin unless the trigger is depressed. It is an additional safety. To test this safety, with the gun unloaded and with the finger out of the trigger guard, pull the hammer back and release it prior to being fully engaged. The hammer should fall to the half-cocked position and not strike the firing pin.



PREPARING TO SHOOT

- Always point the pistol in a safe direction.
- Make sure that the pistol is in safe mode (Picture 9).
- Make sure there is no obstruction in the barrel.
- Check if the pistol is operating properly.
- Ensure the magazine is fitting correctly.

LOADING THE MAGAZINE

- Hold the magazine in an upright position.
- Push the cartridge downwards and to the rear of the magazine.
- Fully load the magazine.



WARNING

You can check the number of cartridges in the magazine from the visible holes on the slide of the magazine. Loading more than magazine capacity can damage your magazine.

LOADING THE PISTOL

- Point the pistol in a safe direction.
- Put the loaded magazine into the pistol and ensure the magazine release catches.
- Pull the slide back to the end and release it freely.
- Now the pistol is loaded and ready to fire.
- Re-engage safety if not ready to fire.



WARNING

Pistol is loaded and ready to be fired. Keep your finger out of the trigger guard and off the trigger until you intend to fire.

TARGETING

The sight alignment is created by arranging the front and rear sights on the same line. Ensure there is equal spacing on either side of the front sight when viewed through the rear sight and that the two sights are level.



WARNING

After the first shot, the pistol is automatically loaded and the hammer is cocked, the pistol is ready to be fired again. If you do not intend to fire again, keep your finger off the trigger and set the safety/decocking lever on safe.

SHOOTING

- Point the pistol at the target, rotate the safety lever down (Picture 10).
- When you are ready to fire, while holding the grip to deactivate the grip safety, pull the trigger and fire.
- After the last round is fired, the slide remains open and locked to the rear. To continue firing, remove the empty magazine and insert a loaded magazine.
- Press the slide release lever to release the slide and load the chamber.

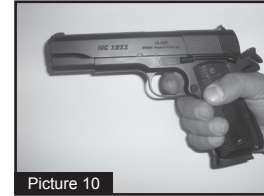

UNLOADING THE PISTOL

- The pistol can still be loaded even when the magazine is removed.
- Point the barrel of the pistol in a safe direction.
- Press the magazine release button to take the magazine out.
- Pull the slide back to remove the cartridge from the chamber.
- Release the slide back to the front, after ensuring that the chamber is empty (visually and physically ensure there is not a cartridge in the chamber).

UNLOADING THE MAGAZINE

- Push the cartridge forward until releasing from the magazine.
- Continue this until extracting all the cartridges from the magazine.



WARNING

Use only original factory ammunition and make sure that the caliber of the ammunition and the pistol is the same. Use of reloaded ammunition voids warranty.

8. MAINTENANCE AND CLEANING

- Make sure that the pistol is unloaded before starting maintenance.
- If the pistol is not unloaded follow unloading instructions (see *Unloading the Pistol*, on the previous page).
- Maintenance of the pistol should be done after every shooting. The maintenance and cleaning kit provided with the pistol includes two cleaning brushes, one ramrod, and oil.

DISASSEMBLY OF THE PISTOL

Make sure that the pistol is unloaded before disassembly.

- Take the magazine out by pressing the magazine release button (see *Picture 4*, page 13).
- Hold the pistol with strong hand.
- Depress the recoil spring plug enough to allow the barrel bushing to rotate.
- While depressing the recoil spring plug, at the same time turn the barrel bushing clockwise, enough to allow the recoil spring to clear the shoulder on the barrel bushing.
- Carefully release the pressure on the recoil plug allowing the recoil spring plug and recoil spring to come out of the firearm (Pictures 11 and 12).
- Rotate the barrel bushing counter clockwise and remove (Picture 13).
- Pull the slide back until the small notch (second notch from the top of the slide) is even with the disassembly latch and hold the pistol in this position (Picture 14).

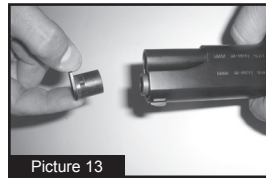
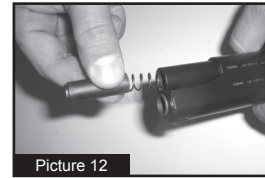
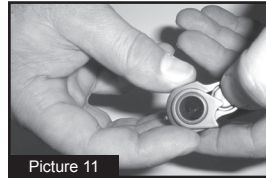

- Remove the disassembly latch by pressing the top of the disassembly latch with the index finger (Picture 15).
- Separate the disassembly lever from the pistol (Picture 16).
- Hold the slide with weak hand and separate the slide from the frame (Picture 17).
- Remove the recoil spring holder which is located on the barrel (Picture 18), remove the barrel from the seating on the slide by holding the barrel locking piece and lifting 2 mm up and then remove the barrel from the slide by pushing forward from the top of the barrel (Pictures 19, 20 and 21).



Picture 15



Picture 16



Picture 17



Picture 18

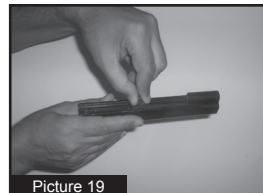

Picture 19



Picture 20



Picture 21

CLEANING THE PISTOL

Cleaning and oiling the barrel:

- Spray a little gun oil on the brush.
- Insert the brush into the barrel from breach or chambered end (Picture 22).
- Brush the inside of the barrel by pushing forward and backwards.
- Wipe the inside of the barrel with a clean and dry patch until the patch comes out clean (Picture 23).
- Clean the barrel locking block with the brush sprayed with protective oil. If necessary, you can apply oil lightly to the outside of the barrel by passing a clean cotton patch soaked in protective oil through it (Picture 24).

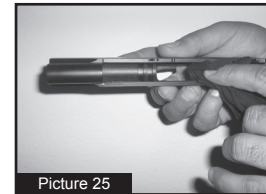
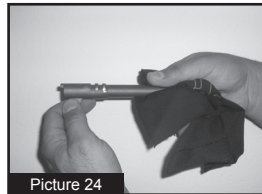
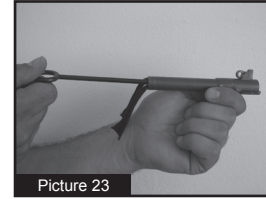
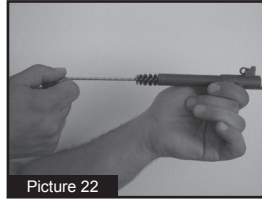

Cleaning the slide and oiling:

- Clean the slide with the oiled brush (Picture 25).
- Lightly oil the slide.
- A good method is to allow a drop of oil to flow down the slide rails by gravity (Picture 26).



WARNING

Do not oil the firing pin hole while cleaning.

Clean and oil the recoil spring and recoil rod:

- Lightly oil the recoil spring and recoil rod (Picture 27).

Clean and oil the frame:

- Clean all surfaces carefully (Picture 28).
- Put a light coat of oil on the rails and trigger bar – sear connection (Picture 29).

Clean and oil the magazine:

- Make sure the magazine is empty.
- Pull the magazine butt-plate down and remove it utilizing the tool provided to unlock the floor plate.
- Remove debris inside the magazine with the brush.
- Clean the inside and outside of the magazine
- Assemble the magazine by applying the reverse method of disassembly.



Picture 27



Picture 28

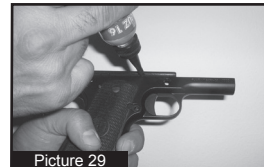

Picture 29

Note: Other firearms cleaners can be used in place of oil.

ASSEMBLY OF THE PISTOL

- Hold the slide in a upside down position (Picture 30).
- Insert the barrel so it engages into the locks in the slide (Picture 31). Ensure that the barrel locking piece is rotated towards the rear (Picture 32).
- Set the recoil spring guide piece on the barrel (Pictures 33 and 34).
- Hold the slide with weak hand with thumb holding the recoil spring guide and barrel in place. Hold the frame with strong hand and put the slide on the frame (Picture 35), and replace the disassembly latch/slide release through the locking piece (Pictures 36).

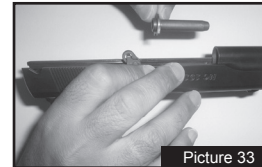
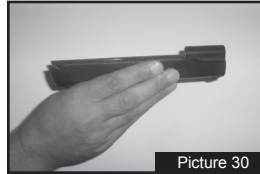

- Hold the pistol with its barrel in an upward position. Align and insert the barrel bushing into the barrel (Picture 37). Rotate the barrel bushing counter clockwise until it stops (Picture 38).
- Connect the recoil spring guide and recoil spring. Place the recoil spring guide and recoil spring inside the slide (Picture 39).
- Rotate the barrel bushing clockwise with the index finger while pressing the recoil spring guide down with the thumb (Picture 40). Continue rotating the barrel bushing until it is correctly in place (Picture 41).
- Assembly of the pistol is complete.
- Perform function check.

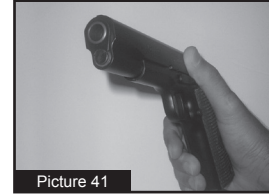
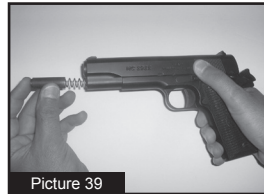
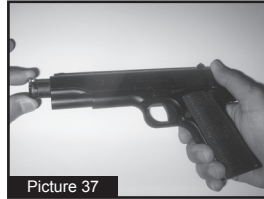

9. TROUBLESHOOTING

PROBLEM	POSSIBLE REASON	SOLUTION
Misfire	Damaged cartridges	Replace cartridges
	Firing pin problem	Clean the firing pin
		Send it to the authorized service center
	The slide did not close correctly	Check for obstruction
Send it to the authorized service center		
Feeding problem	Magazine is not inserted correctly	Re-insert the magazine into the magazine well
	Faulty magazine	Exchange the magazine
	Dirty magazine	Clean the magazine
Ejection problem	Dirty chamber	Clean and oil lightly
	Ejection problem	Send it to the authorized service center
	Extraction problem	Send it to the authorized service center

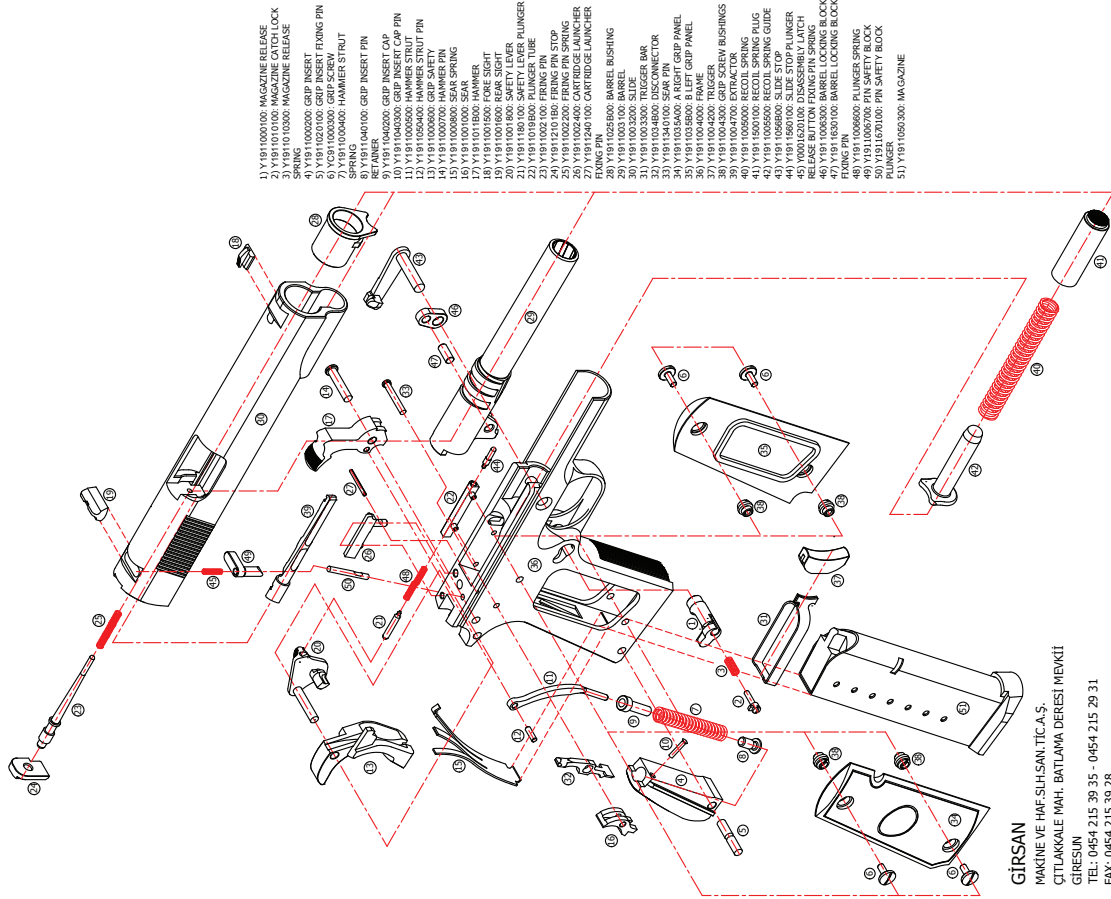
(.45AUTO) MC1911 EXPLODED DRAWING

- 1) Y191100100 MAGAZINE RELEASE
- 2) Y1911010100 MAGAZINE CATCH LOCK
- 3) Y1911010000 MAGAZINE RELEASE
- 4) Y1911000200 GRIP INSERT
- 5) Y1911021000 GRIP INSERT FIXING PIN
- 6) Y1911000300 GRIP SAFETY SPRING
- 7) Y1911000400 HAMMER STRUT SPRING
- 8) Y1911041000 GRIP INSERT PIN
- 9) Y1911040200 GRIP INSERT CAP
- 10) Y1911040300 GRIP INSERT CAP PIN
- 11) Y1911000500 GRIP SAFETY SPRING
- 12) Y1911000600 HAMMER STRUT PIN
- 13) Y1911000600 GRIP SAFETY SPRING
- 14) Y1911000700 HAMMER PIN
- 15) Y1911000800 SEAR SPRING
- 16) Y1911001000 SEAR
- 17) Y1911018000 HAMMER
- 18) Y1911018100 HAMMER PIN
- 19) Y1911001800 REAR SIGHT
- 20) Y1911001800 SAFETY LEVER
- 21) Y1911001900 SAFETY LEVER PLUNGER
- 22) Y1911002000 SAFETY LEVER SPRING
- 23) Y1911002100 FIRING PIN
- 24) Y1911210190 FIRING PIN STOP
- 25) Y1911002200 REAR SIGHT SPRING
- 26) Y1911002400 CARTRIDGE LAUNCHER
- 27) Y1911240100 CARTRIDGE LAUNCHER
- 28) Y1911002500 BARREL BUSHING
- 29) Y1911003100 BARREL
- 30) Y1911003200 SLIDE
- 31) Y1911003300 SLIDE BAR
- 32) Y1911034800 DISCONNECTOR
- 33) Y1911341000 SEAR PIN
- 34) Y1911034900 SEAR SPRING
- 35) Y1911035800 B LEFT GRIP PANEL
- 36) Y1911004000 FRAME
- 37) Y1911004200 REAR VIEW BUSHINGS
- 38) Y1911004700 EXTRACTOR
- 39) Y1911005000 RECOIL SPRING
- 40) Y1911005000 RECOIL SPRING PINUS
- 41) Y1911006000 SLIDE STOP
- 42) Y1911005600 RECOIL SPRING GUIDE
- 43) Y1911006800 SLIDE STOP
- 44) Y1911006900 DISASSEMBLY LATCH
- 45) Y1911007000 DISASSEMBLY LATCH RELEASE BUTTON
- 46) Y1911008300 BARREL LOCKING BLOCK FIXING PIN
- 47) Y1911007100 BARREL LOCKING BLOCK
- 48) Y1911008600 PLUNGER SPRING
- 49) Y1911008700 PLUNGER SPRING PIN
- 50) Y1911071000 PIN SAFETY BLOCK
- 51) Y1911009300 MAGAZINE

GİRSAN

MAKİNE VE HAFT.ŞİH.SAN.TİC.A.Ş.

ÇİTLAKKALE MAH. BATILANA DERESİ MEVKİİ

GİRESUN

TEL: 0454 215 39 35 - 0454 215 29 31

FAX: 0454 215 39 28

http://www.yavuz16.com

e-posta: yavuz16@yavuz16.com

(.45AUTO) MC1911S EXPLODED DRAWING

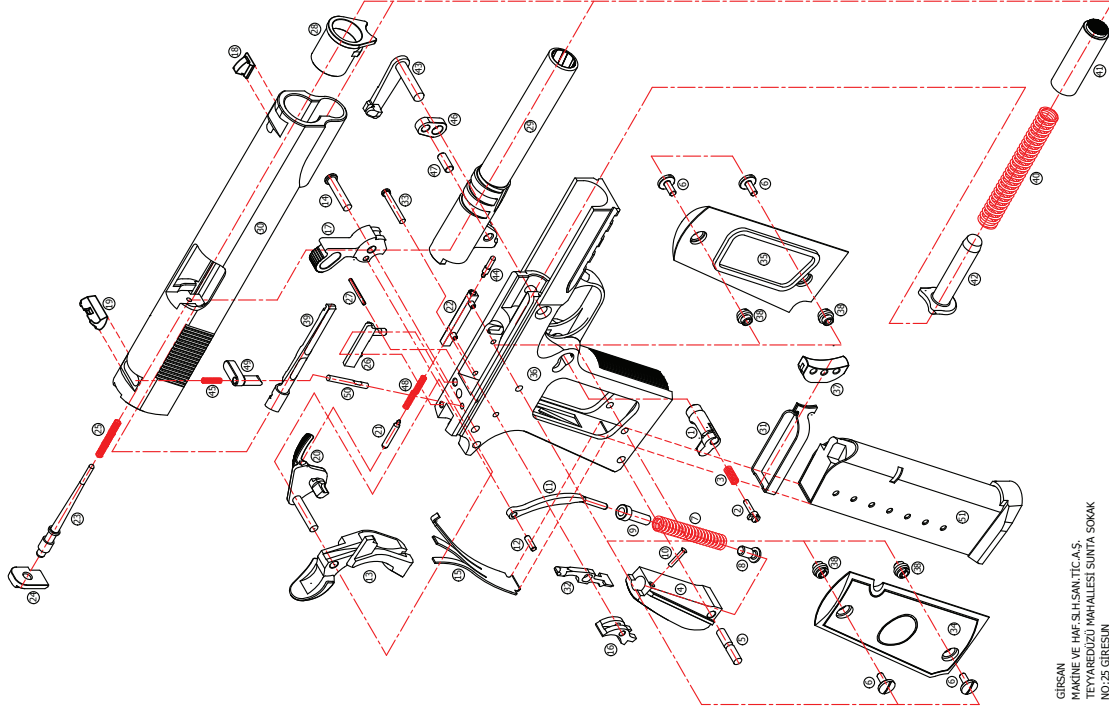

- 1 Y1911000105 MAGAZINE RELEASE
- 2 Y1911010100 MAGAZINE CATCH LOCK SPRING
- 3 Y1911010300 MAGAZINE RELEASE SPRING
- 4 Y1911020100 GRIP INSERT
- 5 Y1911020100 GRIP INSERT
- 6 Y03911000000 GRIP SCREW SPRINGS
- 7 Y03911000000 GRIP SCREW SPRINGS
- 8 Y1911040100 GRIP INSERT PIN
- 9 Y1911040200 GRIP INSERT PIN
- 10 Y1911040300 GRIP INSERT CAP PIN
- 11 Y19110000000 HAMMER STRUT
- 12 Y19110000000 HAMMER STRUT PIN
- 13 Y19110000000 GRIP SAFETY
- 14 Y19110000000 HAMMER PIN
- 15 Y19110000000 SEAR SPRING
- 16 Y19110000000 SEAR
- 17 Y19110018000 HAMMER
- 18 Y19110015000 FORE SIGHT
- 19 Y19110015000 HAMMER
- 20 Y19110018000 SAFETY LEVER
- 21 Y19111801000 SAFETY LEVER PLUNGER
- 22 Y19110018000 SAFETY LEVER
- 23 Y19110010000 FIRING PIN
- 24 Y19112101500 FIRING PIN STOP
- 25 Y19110022000 FIRING PIN SPRING
- 26 Y19110022000 FIRING PIN SPRING
- 27 Y19112401000 CARTRIDGE LAUNCHER FIRING PIN
- 28 Y19110016000 BARREL BUSHING
- 29 Y19110020000 BARREL
- 30 Y19110032000 SLIDE
- 31 Y19110032000 SLIDE
- 32 Y19110034000 DISCONNECTOR
- 33 Y19110034000 SEAR PIN
- 34 Y19110034000 A RIGHT GRIP PANEL
- 35 Y19110034000 LEFT GRIP PANEL
- 36 Y19110040000 FRAME
- 37 Y19110004200 TRIGGER
- 38 Y19110004200 EXTRACTOR
- 39 Y19110004200 BUSHINGS
- 40 Y19110006000 RECOIL SPRING
- 41 Y19110006000 RECOIL SPRING PLUG
- 42 Y19110006000 RECOIL SPRING PLUG
- 43 Y19110006000 SLIDE STOP
- 44 Y19110006000 SLIDE STOP PLUNGER
- 45 Y19110006000 SLIDE STOP PLUNGER
- 46 Y19110006000 BARREL LOCKING BLOCK
- 47 Y19110006000 BARREL LOCKING BLOCK
- 48 Y19110006000 PLUNGER SPRING
- 49 Y19110007000 PIN SAFETY BLOCK
- 50 Y19110007000 PIN SAFETY BLOCK
- 51 Y19110003000 MAGAZINE

GIRSAN
 MAKINE VE HAF.SI.H.SAN.TIC.A.Ş.
 TEYAREDAZISI MAHALLESİ SUNTA SOKAK
 NO:25 GİRESUN
 TEL: 0454 215 35 35 - 0454 215 29 31
 FAKS: 0454 215 35 35
 E-POSTA: girsan@girsan.com
 HTTP://WWW.GIRSAN.COM

(.45AUTO) MC1911C EXPLODED DRAWING

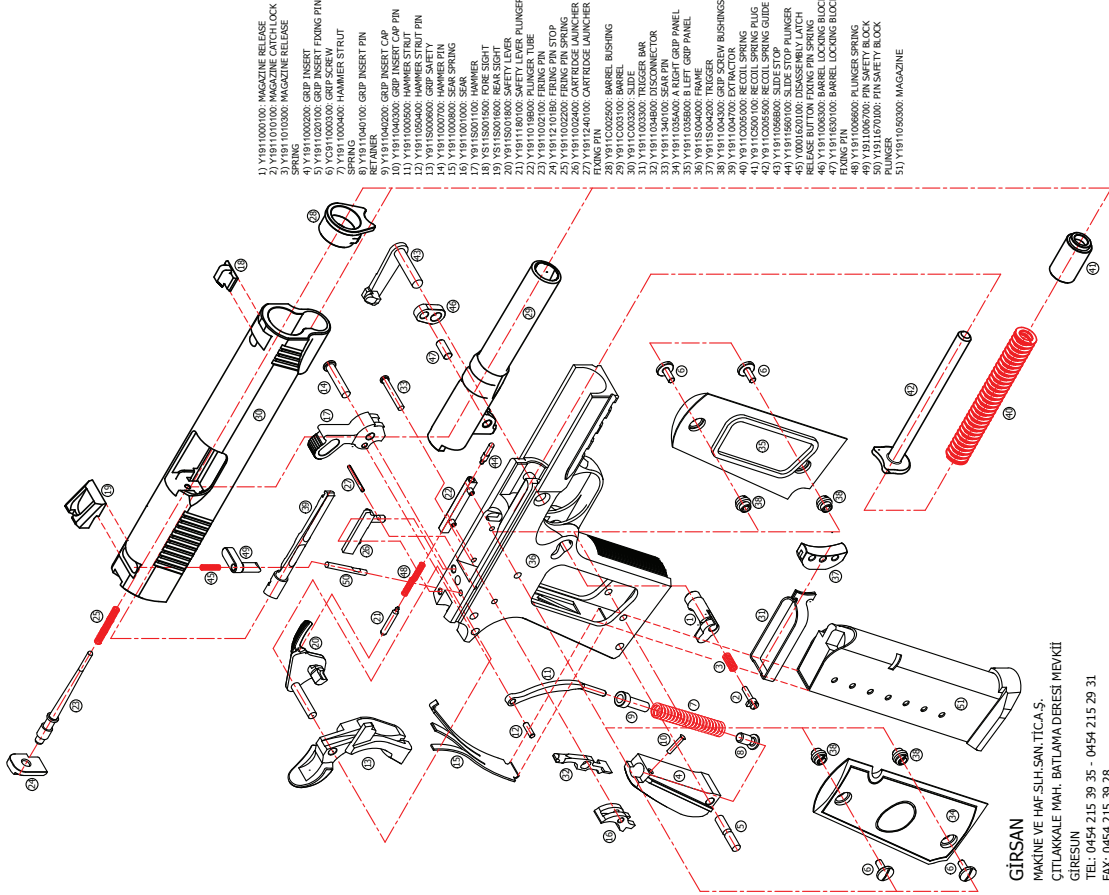

- 1) Y1911000100 MAGAZINE RELEASE
- 2) Y1911010100 MAGAZINE CATCH LOCK
- 3) Y1911010000 MAGAZINE RELEASE
- 4) Y1911000000 GRIP INSERT
- 5) Y1911020100 GRIP INSERT FIRING PIN SPRING
- 6) Y1911000000 GRIP SCREW
- 7) Y1911000000 HAMMER STRUT SPRING
- 8) Y1911040100 GRIP INSERT PIN
- 9) Y1911040200 GRIP INSERT CAP
- 10) Y1911040300 GRIP INSERT CAP PIN
- 11) Y1911000000 HAMMER STRUT
- 12) Y1911000000 HAMMER STRUT PIN
- 13) Y1911000000 GRIP SAFETY PIN
- 14) Y1911000000 HAMMER PIN
- 15) Y1911000000 HAMMER SPRING
- 16) Y1911001000 SEAR
- 17) Y1911001100 HAMMER
- 18) Y1911001200 HAMMER PIN
- 19) Y1911001600 REAR SIGHT
- 20) Y1911001800 SAFETY LEVER
- 21) Y1911001900 SAFETY LEVER SPRING
- 22) Y1911002000 SAFETY LEVER PIN
- 23) Y1911002100 FIRING PIN
- 24) Y1911210100 FIRING PIN STOP
- 25) Y1911002200 FIRING PIN SPRING
- 26) Y1911002400 CARTRIDGE LAUNCHER
- 27) Y1911210100 CARTRIDGE LAUNCHER
- 28) Y1911002500 BARREL BUSHING
- 29) Y1911003100 BARREL
- 30) Y1911003200 SLIDE BAR
- 31) Y1911003300 SLIDE BAR PIN
- 32) Y1911003400 SEAR PIN
- 33) Y1911003500 SEAR PIN SPRING
- 34) Y1911003600 LEFT GRIP PANEL
- 35) Y1911003800 LEFT GRIP PANEL
- 36) Y1911004000 FRAME
- 37) Y1911004200 TRIGGER
- 38) Y1911004300 TRIGGER SPRING
- 39) Y1911004700 EXTRACTOR
- 40) Y1911005000 RECOIL SPRING
- 41) Y1911005100 RECOIL SPRING GUIDE
- 42) Y1911005200 RECOIL SPRING GUIDE
- 43) Y1911005800 SLIDE STOP
- 44) Y1911006000 SLIDE STOP SPRING
- 45) Y1911006100 SLIDE STOP PLUNGER
- 46) Y1911006200 SLIDE STOP PLUNGER SPRING
- 47) Y1911006300 SLIDE STOP PLUNGER RELEASE BUTTON FIRING PIN SPRING
- 48) Y1911006500 BARREL LOCKING BLOCK FIRING PIN
- 49) Y1911006600 BARREL LOCKING BLOCK FIRING PIN
- 50) Y1911007000 PIN SAFETY BLOCK PLUNGER
- 51) Y1911008000 MAGAZINE

GİRSAN
 MAKİNE VE HAF.Sİ.H.SAN.TİC.A.Ş.
 ÇITILAKKALE MAH. BATILANLA DERESİ MEYDİ
 GİRESUN
 TEL: 0454 215 39 35 - 0454 215 29 31
 FAX: 0454 215 39 28
 http://www.yavuz16.com
 e-posta: yavuz16@yavuz16.com



Zenith Firearms Warranty

At Zenith Firearms, we believe in the quality of our firearms, and we want you to as well.

Age and wear cannot be covered under warranty, as the mechanical parts and materials that make up firearms eventually wear out. However, defective parts, materials, and workmanship are not acceptable, and we will stand behind our products. We warrant our firearms to be free from defects in performance and workmanship for one year from the date of purchase. If you have a problem that is directly attributable to the quality of our product, it's on us to make it right, shipping and handling included.

However, if you abuse, improperly maintain, or alter the internal workings of your Zenith firearm in any way, we will not warranty damage that occurs. Likewise, if you use improper or incompatible ammunition or parts, we will not warranty damage that occurs. This includes altering a serial number.

If you have a problem with your firearm, please contact a customer service representative at 434-202-7790.

RETURN WITHOUT REPAIR

If we receive your firearm and determine that its damage is unwarrantable, we will contact you with an explanation and an estimation of your cost to have us repair or refurbish it. If you would rather we simply return your firearm to you, we will cover the cost of shipping to do so.

FREE REPAIR AND RETURN

If your firearm is defective and we determine the defect is warranted, Zenith will try to repair it. If we repair your firearm, after doing so we will ship it directly back to you, provided you originally shipped it to us from your address. If your firearm cannot be repaired, we will consider replacing it. If we end up replacing your firearm, we will ship it back to you via a licensed FFL dealer, and there may be additional charges that you'll have to cover, such as transfer fees and background check fees. In either case, though, we will pay for shipping.

LIMITATIONS ON WARRANTY

OUR ONLY RESPONSIBILITY IN THE CASE OF BREACH OF WARRANTY IS REPAIR. ZENITH FIREARMS SHALL NOT BE LIABLE FOR ANY OTHER DAMAGES, INCLUDING DIRECT, INDIRECT, OR CONSEQUENTIAL DAMAGES.

Please Note: This warranty gives you specific legal rights, and you may also have other rights, which vary from state to state, as some jurisdictions do not allow limitations on certain damages and warranties.



Zenith Firearms

10950 Rockfish Valley Highway, Suite C, Afton, VA 22920

Tel: 434.202.7790 | Fax: 800.466.4444 | info@zenithfirearms.com | www.zenithfirearms.com