



CMMG

Radial Delayed Blowback Models

MkG/MkGs/Mk57/Mk10

Covers

BANSHEE™

and

RESOLUTE™

rifle models

INSTRUCTION MANUAL

**WARNING: BEFORE USING THIS FIREARM, READ AND
FOLLOW THESE INSTRUCTIONS**



Thank you for choosing CMMG, Inc.
Please follow all instructions in this manual before operating
your new firearm.

Fundamental Firearm Safety Rules

1. Always keep the firearm pointed in a safe direction.
2. Always keep your finger off the trigger until ready to shoot.
3. Always keep the firearm unloaded until ready to use.
4. Know the target and what is beyond.
5. Know how to use the firearm safely.
6. Use only the correct ammunition for the firearm.
7. Be sure the firearm is safe to operate.
8. Wear appropriate eye and ear protection.
9. Never use alcohol or drugs before or while shooting.
10. Store firearms so they are not accessible to unauthorized persons.
11. Be aware certain types of firearms and many shooting activities require additional safety precautions.

Failure to follow these rules can result in damage to property, injury or death. Always follow these instructions and carefully read and refer to this manual before loading firearm.

THIS IS *NOT* A SAFETY MANUAL

If you need assistance with the safe handling of this, or any firearm, please contact a certified firearms instructor or school.

Table of Contents

Operating Procedures

Unloading and Clearing Your Rifle	1
Loading and Firing Your Rifle	2

Basic Care and Maintenance

Disassembly Instructions	5
Upper Maintenance	10
Bolt and Carrier Maintenance	12
Lower Maintenance	13
Reassembly Instructions	14
Function Check	15
Lifetime Quality Guarantee	16
Contact Information	16

Please familiarize yourself with this manual and the operation of your particular firearm. To ensure you get the best performance and reliability from your new CMMG firearm, please read through all of the procedures listed in this manual before attempting to perform any of the described actions. If any part of this manual is unclear to you, please contact us before attempting the procedure.

All complete firearms and uppers are headspaced and test fired before shipping.

Clean your firearm before using for the first time.

**All Virtual Patent Marking information can be found at:
<https://www.cmmginc.com/patents/>**

Unloading and Clearing Your Rifle

To unload and clear your rifle:

1. Keep your rifle pointed in a safe direction for the duration of the procedure.
2. Place your selector on "SAFE". You cannot select "SAFE" unless the hammer is cocked.
3. Depress the magazine catch button and remove the magazine.
4. Eject the chambered cartridge by retracting the charging handle until it stops. Let the ejected cartridge fall to the ground.
5. While holding the charging handle to the rear inspect the chamber and receiver to ensure you have removed all cartridges from the action.
6. Release charging handle once you have verified the chamber to be clear and no cartridges are in the firearm.

Your rifle is now unloaded and clear. It may now be loaded or prepped for transportation or storage.

Loading and Firing Your Rifle

The following is a description of the sequence for one complete firing cycle; beginning after a cartridge is chambered. Knowing the correct function of your rifle will help you with the diagnosis of any malfunctions or failures to fire.

The trigger is pulled, releasing the hammer which strikes the firing pin. The firing pin impacts the primer in the chambered cartridge, igniting the primer which ignites the powder. As the powder is burned it creates a high volume of gas, propelling the bullet down the bore of the barrel. The gas pushes the bolt carrier back unlocking your bolt from the barrel extension allowing the bolt carrier to recoil completely. The underside of the carrier will push the hammer down where it is caught and held by the disconnecter. The bolt will pull the spent cartridge out of the chamber and eject it from the rifle.

At full recoil the carrier has pushed the buffer and action spring back into the receiver extension. The magazine will present a new cartridge, which will be stripped from the magazine by the bolt as the recoil spring pushes the bolt carrier group back into battery. The new cartridge is now chambered. The fire control group will reset once you have released the trigger allowing the disconnecter to release the hammer and re-engage the trigger's sear. The rifle is ready to be fired again or put on "SAFE" and unloaded.

Loading and Firing Your Rifle

continued

To load and fire your rifle:

Begin with a rifle that has been verified to be unloaded using the preceding directions. Make sure the selector is on safe.

1. Keep your rifle pointed in a safe direction for the duration of the procedure.
2. Load your magazine with proper ammunition.

MkG/MkGs/Mk10 - Place cartridge in front of feed lips, press down until it is below feed lips and then slide fully to the rear.

Mk57 - Place cartridge between the magazine's feed lips and push down to seat.

3. To insert your magazine, align the top of the magazine with the magwell and press upwards until it locks in place. Pull the magazine down to verify that it is locked in place.
4. Retract the charging handle fully to the rear. Release the charging handle. Do not maintain control of the charging handle while chambering a cartridge as this will cause the rifle to misfeed. **Your rifle is now loaded.**
5. Get into the shooting position you plan to use. Grasp the pistol grip in one hand and the handguard in the opposite hand with the buttstock to your shoulder.
6. Align your sights on your target.
7. Place the selector on "FIRE"; **Your rifle is now ready to shoot.**
8. Squeeze the trigger until the hammer is released.

Loading and Firing Your Rifle

continued

IMPORTANT NOTES:

1. Forcing a fully loaded magazine to seat on a closed bolt can cause permanent magazine damage that will make it unusable. Magazines should either be loaded 1 less than full, or only inserted with the bolt caught to the rear.
2. Cast bullets, or any bullet that has a shoulder (wadcutter, semi wadcutter, etc.) are not recommended. As the bolt cycles to the rear it can catch on these types of projectiles which can cause malfunctions or in extreme cases damage.
3. **MkG/MkGs** - For maximum reliability we recommend only using Glock[®] manufactured magazines. The CMMG MkG/MkGs was designed to fit and function as reliably as possible with Gen3 or Gen4 Glock magazines. Gen2 or older magazines require modification to fit into the magazine well and may not be as reliable as the recommended Gen3 or Gen4 magazines.

Mk57 - For maximum reliability we recommend only using FN Herstal manufactured 20-round and 10-round FN Five-seveN magazines, or ProMag manufactured 20-round and 10-round FNH magazines.

Mk10- For maximum reliability we recommend only using SGM manufactured 30-round magazines.

Loading and Firing Your Rifle

continued

IMPORTANT NOTES:

Continued

Mk10

Due to the wide variety of 10mm ammunition offerings, the Mk10 ships with an additional buffer to help you fine tune the firearm to your preferred ammunition. Having the correct buffer installed is important in maintaining proper firearm function, maximizing reliability and performance, as well as reducing recoil and part wear. To determine which buffer you will need to install, you first need to calculate the power factor of your ammunition:

$$\text{Power Factor} = \frac{\text{Bullet Weight (grains)} \times \text{Muzzle Velocity (fps)}}{1000}$$

Power Factor	Recommended Buffer
< 190	Carbine Buffer (Ships with Firearm in Box)
> 190	H3 Buffer (Installed in Firearm from Factory)
> 230 Extended use or suppressed	CMMG 8oz Buffer (Sold Separately)

The above table applies to brass cased ammunition only. Aluminum cased ammunition typically requires a lighter buffer than the power factor indicates. This table should be used as a guide but may not always represent the best configuration for your ammunition or use. If the ejection pattern of your firearm is consistently at 1-2 o'clock, installing a heavier buffer is recommended. If the bolt fails to consistently lock open after the last round is fired, installing a lighter buffer is recommended.

*Power factor should be calculated using ammunition manufacturer specifications.

Loading and Firing Your Rifle

continued

IMPORTANT NOTES:

Continued

CMMG strongly advises against reloading brass that shows signs of bulging at it's base. This brass has been severely weakened from being fired and is not suitable for reloads. Internal deformation may be present that is not easily visible from the outside.

4. If using a suppressor or +P ammunition it is recommended to purchase the Action Tuning Kit, (CMMG Part 45AFF17). With the Action Tuning Kit, you can fine tune the action to perform to your liking while reducing the wear and tear on the shooter and firearm while using suppressors or +P ammunition. For additional information on the Action Tuning Kit visit our website, www.cmmginc.com.

Disassembly Diagram

Use illustrations as a guide for the following instructions

Guard Rifle:

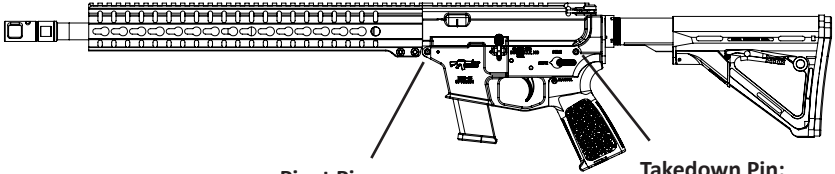

Lower Receiver Group:

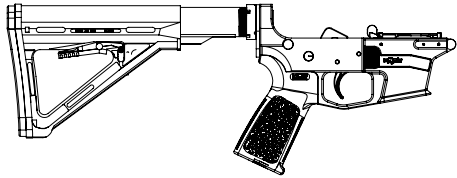

Buffer and Spring:



Buffer Detent:

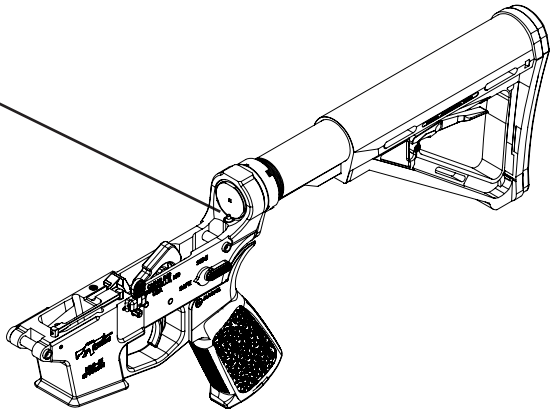

Disassembly Diagram

Use illustrations as a guide for the following instructions

Upper Receiver Group:



Charging Handle:

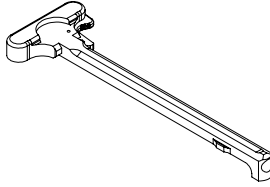

Bolt Carrier Group:

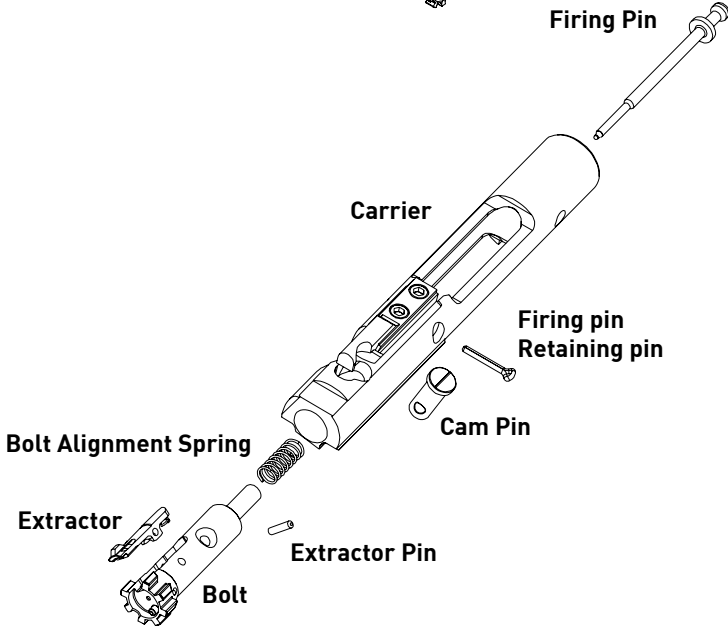
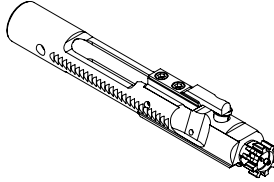

Disassembly Instructions

Before disassembling your rifle please unload and clear your rifle as described in the unloading directions.

1. Verify your rifle is unloaded and return the bolt and carrier into battery.
2. Partially push the rear take down pin and the front pivot pin from the left so they are not captured by the detents that retain them in the receiver in the closed position. Use a delrin take down pin punch if needed.
3. Pull the rear take down pin the rest of the way to the right side of the lower receiver until it engages the detent that holds the pin in the open position.
4. Pivot the lower receiver away from the upper receiver.
5. Pull the front pivot pin the rest of the way to the right side of lower receiver until it engages the detent that holds the pin in the open position.
6. The upper and lower receiver groups are now separated; set the upper receiver group aside.

Disassembly Instructions

continued

7. Remove the buffer and action spring from the lower receiver by depressing the buffer detent. Maintain tension on the buffer face while removing; it is under pressure from the action spring. You may need to hold the hammer down to allow the buffer and spring to be removed from receiver extension.
8. Set the lower receiver, buffer and recoil spring aside and pick the upper receiver back up.
9. Pull the charging handle to rear and remove bolt and carrier assembly. Set the bolt and carrier assembly aside.
10. Remove the charging handle by pulling it backwards until it is aligned with the key way. The charging handle may now be lifted from the upper receiver.
11. Set the upper receiver and the charging handle aside and pick the bolt carrier assembly back up.
12. Remove the firing pin retaining pin from the left side of the bolt carrier group. You may use a small screwdriver or punch to hook the loop end of the firing pin retaining pin. To further aid disassembly you may need to slightly depress the firing pin to relieve tension from the bolt alignment spring.
13. Tilt bolt face up and remove firing pin from the rear of the bolt carrier.

Disassembly Instructions

continued

14. Push bolt into the carrier until it rotates and comes to a stop (in battery position).
15. Lift cam pin out from bolt and carrier.
16. Pull bolt forward out of carrier. Set the carrier aside.
17. Gently remove the bolt alignment spring from the bolt. Set the spring aside.
18. With a punch, remove the extractor pin from the bolt assembly. Slight pressure applied to the extractor will ease removal of the extractor pin.
19. Remove the extractor. The extractor spring and rubber buffer should be captured in the extractor; do not remove the spring or rubber buffer from the extractor.

Your rifle is now field stripped for cleaning.

Do not disassemble your firearm any further than described. Any maintenance that requires further disassembly should be performed by CMMG or a qualified gunsmith.

Basic Care and Maintenance

Proper maintenance will ensure you get the best performance from your firearm. High quality cleaning products will ensure you get your rifle clean quickly and without damage to your firearm. If you use corrosive ammunition, it is advised to clean your rifle's bolt carrier group and barrel bore with diluted ammonia to neutralize the corrosive salts. This should be followed with a hot water rinse. Using hot water will aid in evaporation. After cleaning is complete and the water is removed, you should lubricate with quality firearm lubricant.

Upper Maintenance

1. Use cleaning fluid on the bore and chamber, the upper receiver and barrel assembly, locking lugs and all areas of powder fouling, corrosion, dirt or dust.
2. Install the chamber brush on the cleaning rod, dip the brush in cleaning fluid and insert it into the chamber and locking lugs. Clean by pushing and twisting the cleaning rod.
3. Install the bore brush on the complete cleaning rod. Dip the brush in cleaning fluid. Run the rod through the chamber and flash suppressor or muzzle brake several times.
4. Take the bore brush off the rod and install a swab holder and a swab. Apply cleaning fluid to the swab, then run it through the chamber and out the flash suppressor (if applicable). To remove carbon build up, let the solvent sit, then wipe clean. Wipe the bore dry by running clean swabs all the way through from the chamber to the flash suppressor.

Upper Maintenance

continued

5. Once the patches come out dry they should be clean. If not, repeat steps 3 and 4.
6. Wipe the charging handle with a patch dipped in solvent; wipe off solvent with a dry cloth.
7. Inspect the upper assembly for any worn, broken or damaged parts. Replace any faulty parts with quality replacement parts.
8. Lightly lubricate the bore, chamber and charging handle.
9. With a lubricated swab, run the rod from the receiver to the flash suppressor or muzzle brake. Do not over lubricate.
10. Lubricate the locking lugs.
11. Reassemble upper.

Bolt and Carrier Maintenance

1. Clean all parts and outer surfaces of the bolt carrier assembly with a swab saturated with cleaning fluid.
2. Remove carbon deposits and dirt from the locking lugs with a cleaning brush dipped in cleaning fluid.
3. Clean the bolt and under the lip of the extractor.
4. Use a punch to press the ejector in repeatedly to remove accumulated brass shavings from the ejector hole and assure the ejector moves freely. Be careful not to damage bolt with punch.
5. Inspect the bolt assembly for cracks or fractures, especially in the cam pin hole area. Inspect the firing pin retaining pin for bends, breaks or dents. Inspect the bolt cam pin for cracks or chips. Inspect the firing pin for bends, cracks, or a sharp, chipped or blunted tip.
6. Lubricate the bolt carrier, bolt, cam pin, firing pin and firing pin retaining pin. Be sure to coat the inner and outer surfaces and the cam pin area of the bolt carrier. Flush the ejector with lubricant and cycle the plunger enough to ensure the ejector spring is well lubricated.
7. Reassemble bolt and carrier.

Lower Maintenance

1. Remove any dirt or debris from the trigger group with a cleaning brush and/or cotton swab dipped in cleaning fluid.
2. Remove powder fouling, corrosion and dirt from the lower receiver with a cleaning brush and/or cotton swab dipped in cleaning fluid.
3. Clean the buffer, recoil spring and inside of the lower receiver with a cleaning brush and/or cotton swab dipped in cleaning fluid.
4. Examine the lower receiver assembly for any worn, broken or damaged parts. Replace any faulty parts with quality replacement parts.
5. Lightly lubricate the lower receiver and the internal parts of the lower receiver assembly.
6. Reassemble the lower receiver.

Reassembly Instructions

1. Insert extractor and spring assembly into bolt by pushing extractor assembly down and aligning the pivot hole in the extractor with the hole in bolt and insert extractor pin. If the spring comes loose, seat the large end of spring in the extractor.
2. Slide bolt alignment spring over the tail section of the bolt. Make sure the spring is flush with the base of the bolt and is retained in place.
3. Slide bolt assembly into bolt carrier assembly with extractor claw on the carrier's right side.
4. Align the bolt's cam pin hole with the carrier's cam pin slot and insert bolt cam pin.
5. Insert firing pin in opening at the rear of the bolt carrier and seat. You may need to rotate the cam pin into alignment to allow the firing pin to seat. The line on the head of the cam pin should align with the firing pin.
6. Fully depress the firing pin and replace the firing pin retaining pin. When correctly installed, the firing pin will not fall from the bolt carrier assembly and cannot be removed.
7. Install charging handle assembly into upper receiver. Leave the charging handle halfway out of the receiver.
8. Install the bolt carrier assembly. The bolt must be extended from bolt carrier so the cam pin will not prevent the bolt carrier group's installation.
9. Push charging handle assembly and bolt carrier assembly together into upper receiver.
10. Reinstall the buffer and spring into the lower receiver.
11. The hammer must be cocked and the selector lever must be on "SAFE" before installing the upper onto the lower.

Reassembly Instructions

continued

12. With the bolt carrier in battery, close ejection port cover.
13. Align the pivot pin holes and push pivot pin in.
14. Pivot the lower receiver towards the upper receiver. When aligned, push in take down pin.
15. Perform the function check on your rifle.

Function Check

**TO AVOID ACCIDENTAL FIRING, BE SURE MAGAZINE IS REMOVED
AND CHAMBER IS EMPTY**

1. Pull charging handle assembly to rear and release.
2. Place selector lever on "SAFE". Squeeze trigger. Hammer should not fall.
3. Place selector lever on "FIRE". Squeeze trigger. Hammer should fall.
4. Hold trigger to the rear. Cycle the action. Release trigger. You should hear a click as you release the trigger as the disconnecter hands the hammer off to the the trigger.
5. Squeeze trigger again. Hammer should fall.

If your rifle fails any of these tests check your assembly. If the rifle will not pass these checks and it has been assembled properly, contact CMMG or a qualified gunsmith for assistance.

Lifetime Quality Guarantee

Notice

CMMG, Inc. sells complete firearms and components. If you have received a CMMG, Inc. firearm and are not satisfied, please contact CMMG, Inc. If you suspect your firearm isn't factory built, contact CMMG, Inc. for confirmation.

Returned products that are found without a defect are subject to a restocking fee.

All CMMG firearms are designed to function with a wide variety of factory loaded ammunition and undergo rigorous testing prior to release to ensure reliability and durability. Because CMMG relies on factory ammunition for testing, we cannot guarantee reliable function with handloads or reloads. Warranty claims due to handloads or reloads will be subject to review.

The 5.7x28mm cartridge was designed to compress slightly upon chambering. Due to the unique nature of this cartridge, CMMG recommends against using reloaded, remanufactured, or pulled down brass in the Mk57. Brass that has been once fired or pulled down can potentially have a reduced lacquer coating, which is necessary for proper feeding, extracting, and the prevention of material transfer during firing. Brass that has been remanufactured may also have changes in its mechanical properties that can lead to malfunctions. If reloaded, remanufactured, or pulled down ammunition is used, CMMG recommends cleaning the firearm at least every 200 rounds, inspecting the chamber and verifying it is clear of debris. Failure to do so can result in damage to the firearm, accessories, and/or the user. CMMG strongly recommends using factory produced ammunition from a reputable manufacturer. If you are unsure if the brass is reloaded, remanufactured, or pulled down, please contact the ammunition manufacturer. Contact CMMG technical support at tech-support@cmmginc.com or call 660-248-2293 for all other questions regarding your firearm.

Notes

Notes



CMMG

All Virtual Patent Marking information can be found at:
<https://www.cmmginc.com/patents/>

CMMG Lifetime Quality Guarantee

CMMG, Inc. will guarantee its products against defects in material or workmanship. CMMG, Inc. will repair, replace or substitute part(s) (at CMMG, Inc. discretion) at no charge to the customer if a defect of material or workmanship is found. All service work must be carried out by CMMG, Inc. Please provide a copy of the invoice or proof of purchase when submitting service work.

CMMG Inc.
P.O. Box 68
Boonville, MO 65233

Phone: 660-248-2293

Fax: 660-248-2290

techsupport@cmmginc.com

sales@cmmginc.com



WARNING!

This product can expose you to chemicals including Cadmium, Lead, Cyanide Salts, or Nickel which are known to the State of California to cause cancer and birth defects or other reproductive harm. For more information go to www.P65Warnings.ca.gov

WWW.CMMGINC.COM