

MODEL 95

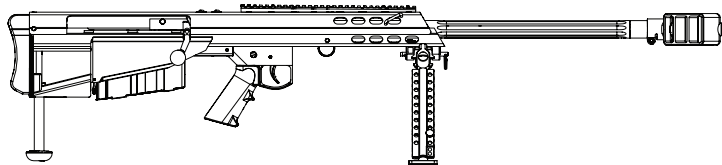

MODEL 95
OPERATOR'S MANUAL



TABLE OF CONTENTS

- 2 MANUFACTURER'S DISCLAIMER**
- 2 USE OF THE MANUAL**
- 3 SAFETY GUIDELINES**
- 5 WARRANTY AND SERVICE**
- 6 DESCRIPTION OF FIREARM**
- 6 BREAK-IN PROCEDURE**
- 6 SPECIFICATIONS**
- 7 MAJOR COMPONENTS**
- 7 SAFETY MECHANISM**
- 8 BIPOD OPERATION**
- 8 LOADING AND FIRING**
- 11 CYCLING THE ACTION**
- 11 UNLOADING AND CLEARING**
- 12 UNLOADING MAGAZINE**
- 12 DISASSEMBLY AND ASSEMBLY**
- 19 CLEANING AND LUBRICATION**
- 20 GENERAL MAINTENANCE**
- 22 TROUBLESHOOTING**
- 24 EXPLODED VIEW**
- 26 PARTS LISTS**

MANUFACTURER'S DISCLAIMER

BFMI will not be responsible for injury, death, or damage to property resulting from either intentional or accidental discharge of this firearm or from its function when used for purposes or subjected to treatment for which it was not designed. BFMI will not honor claims involving this firearm which result from careless or improper handling, unauthorized adjustment or parts replacement, corrosion, neglect, the use of the wrong caliber ammunition, or the use of other than commercially manufactured ammunition in good condition, or any combination thereof.

USE OF THIS MANUAL

Read this manual before you use or manipulate your Barrett product. It is important that you understand the principles of safe gun handling in general and the features of this product. This manual is not a substitute for training from a qualified instructor. Important safety topics are discussed in this chapter and throughout this manual. This manual should remain with the product and it should be transferred with the product to subsequent owners. Additional manuals can be ordered from Barrett Firearms Manufacturing or can be downloaded from the company website, **barrett.net**. Technical specifications are subject to change without notice. Please ensure you have the most updated revision of this manual by checking **barrett.net**. The revision letter can be found on the back of this manual.

SAFETY GUIDELINES

WARNING

**FAILURE TO FOLLOW SAFETY GUIDELINES
MAY CAUSE INJURY OR DEATH**

AMMUNITION

Do not use hand loaded, re-manufactured, or surplus ammunition. Always use new, clean, dry, properly stored, and correct caliber ammunition from reputable manufacturers.

SAFETY DISTANCE

Bullets fired from this rifle may travel as far as 4 miles. Make certain that you have an adequate backstop.

HEARING PROTECTION

Always wear adequate hearing protection when the rifle is firing; wear both earplugs and shooting muffs together for maximum protection. This includes observers. Observers should always be behind the shooter.

EYE PROTECTION

Appropriate eye protection should be worn when both shooting and maintaining your rifle. It is normal for firing to generate airborne dust and debris. Protect your eyes from solvents and uncaptured parts under spring pressure while performing maintenance on your rifle.

MUZZLE CONTROL

Always keep the muzzle pointed in a safe direction. Never allow your muzzle to point at anything that you do not intend to shoot. Upon firing the muzzle brake releases high-pressure gas from its side ports that can damage objects or cause injuries. Keep everything away from the vicinity of the muzzle brake.

ASSUME EVERY GUN IS LOADED

Always treat every gun as if it were loaded. Look and feel for an empty chamber. Do not trust the extractor to provide an empty chamber.

BEWARE OF BARREL OBSTRUCTIONS

Ensure the barrel's bore is free of obstructions before you fire your rifle. Even the smallest obstruction such as a stuck patch or even grease will cause increased pressures that can rupture the barrel.

KEEP YOUR FINGER OFF THE TRIGGER

Keep your finger off the trigger and out of the trigger guard until your sights are aligned on your target and you intend to fire.

KEEP YOUR SAFETY ON

Keep your safety on until your sights are aligned on your target and you intend to fire.

FAILURE TO FIRE

If your rifle fails to fire when you pull the trigger, do not open the bolt. Keep the rifle pointed toward a safe area and wait 2 minutes. If a hang-fire (slow ignition) has occurred, the round will probably fire within two minutes. If the round does not fire, remove and inspect the cartridge. If the primer is indented properly, discard it in a safe manner.

MAINTAIN YOUR RIFLE PROPERLY

Performing proper maintenance, as outlined in this manual, ensures that your rifle will be safe to shoot and will perform to design specification for many years. Alterations, modifications or adjustments may damage your rifle, make it unsafe to fire and will void warranty claims.

STORE YOUR RIFLE SAFELY

It is your responsibility to take reasonable precautions to secure your rifle, keep it properly secured and prevent unauthorized use.

ALCOHOL, MEDICATIONS AND DRUGS

Do not handle or operate your rifle under the influence of alcohol, medications or drugs.

WARRANTY AND SERVICE

For one year from date of purchase, Barrett Firearms Manufacturing Inc. (BFMI), warrants to the original owner, that this product was manufactured free of defects in materials and workmanship. BFMI will correct any defect covered under the warranty by repair or replacement with the same or comparable model. BFMI will not be responsible for injury, death, or damage to property resulting from either intentional or accidental discharge of this firearm or from its function when used for purposes or subjected to treatment for which it was not designed. BFMI will not honor claims involving this product which result from careless or improper handling, unauthorized adjustment or parts replacement, corrosion, neglect, the use of the wrong caliber ammunition, or the use of other than commercially manufactured ammunition in good condition, or any combination thereof. Please visit **barrett.net** for any additional information.

If you need factory service, whether covered under warranty or not, please contact BFMI for instructions on how to have your rifle repaired.

Barrett Firearms Manufacturing Inc.
P.O. Box 1077
Murfreesboro, TN 37133-1077
615-896-2938

DESCRIPTION OF FIREARM - FIGURE 1

The Model 95 rifle is a magazine-fed, bolt-action rifle. The shooter, having inserted a loaded magazine into the rifle, cycles the bolt which strips a cartridge from the top of the magazine and feeds it into the chamber. The firing pin assembly is cocked by lifting the bolt handle. The bolt is equipped with an extractor which removes a cartridge or shell casing. A manually controlled safety prevents or permits trigger movement.

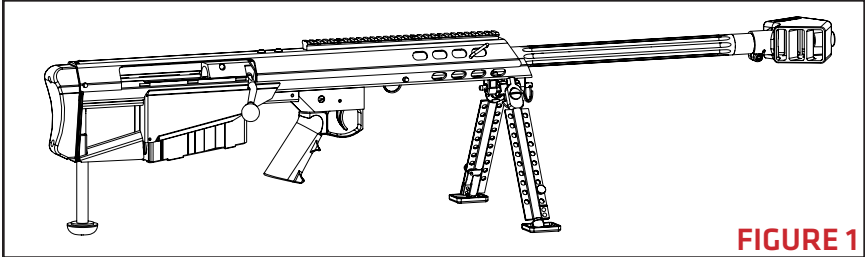
**FIGURE 1**

BREAK-IN PROCEDURE

Barrett does not offer a specific procedure for barrel break-in other than checking for obstructions and using your new rifle. Experience has shown that the bore becomes less prone to fouling over time and that accuracy may improve with use.

SPECIFICATIONS

MODEL	MODEL 95
Caliber	.50 BMG (12.7 x 99)
Operation	Bolt Action
Weight	23.5 lbs (10.7 kg)
Overall Length	45 inches (1143 mm)
Barrel Length	29 inches (736.6 mm)
Barrel Twist	1:15 inches (381 mm)
Magazine Capacity	5 rounds
Scope Rail	Parallel with bore, M1913 style
Safety	Manual thumb - lever

Barrett reserves the right to change specifications without notification.

NOTE: INDIVIDUAL RIFLE SPECIFICATIONS AND WEIGHT MAY VARY PER ORDER AND CONFIGURATION.

MAJOR COMPONENTS - FIGURE 2

1. Upper Receiver
2. Bolt and Bolt Carrier Assembly
3. Lower Receiver
4. Monopod
5. Magazine

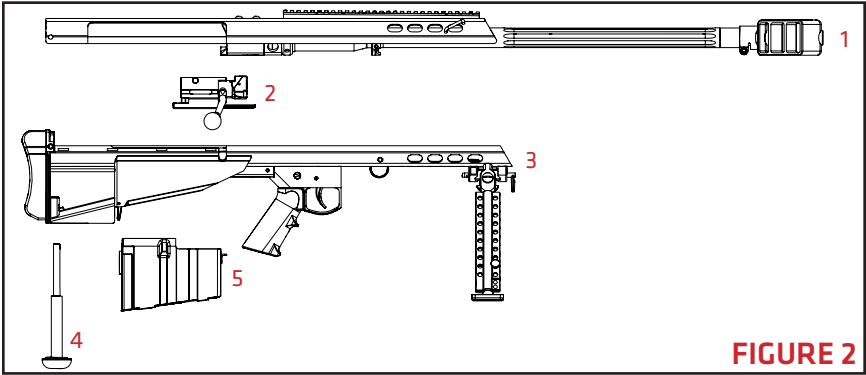

FIGURE 2

SAFETY MECHANISM

The safety mechanism is located above the grip on the left side of the lower receiver. To place the rifle in the safe mode, push the safety lever selector to the “S” (safe) position. To place it in the fire mode, push the safety lever to the “F” (fire) position. **(FIGURE 3)**

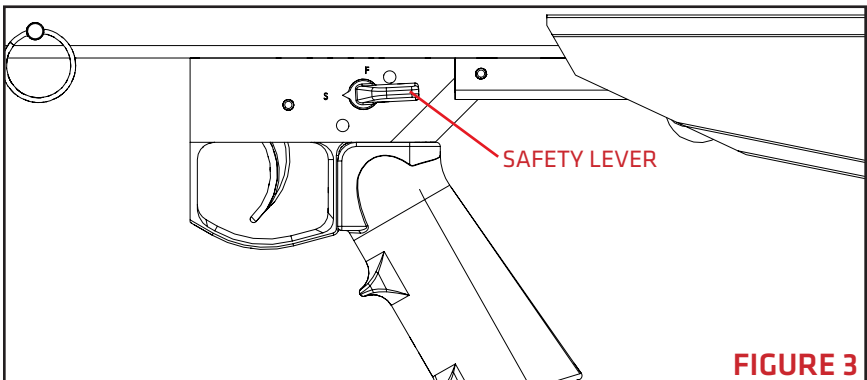

FIGURE 3

BIPOD OPERATION

The bipod assembly is used to fire from the prone position and assist in operator's manipulation of the firearm.

To reposition the bipod legs, pull each bipod leg away from the yoke (**FIGURE 4-A**) and rotate to the desired position (**FIGURE 4-B**). The bipod leg will lock into place (forward, rearward, and 90 degrees from the receiver). The bipod legs of the Model 95 extend to increase height.

Pulling on the feet of the bipod causes the legs to extend. To retract a leg, depress the plunger located on the bipod leg and push on the foot (**FIGURE 4**).

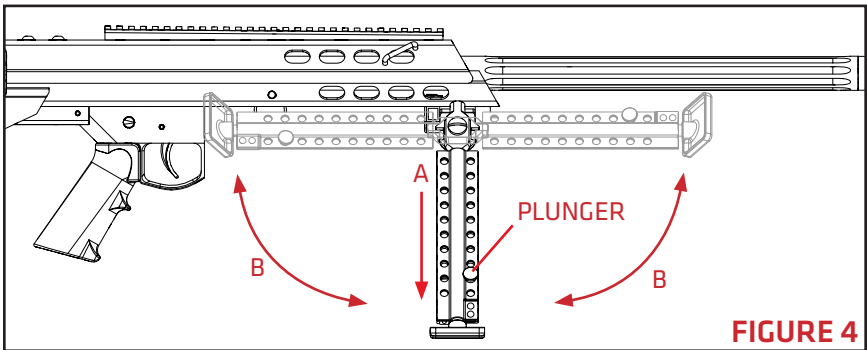

LOADING AND FIRING

1. Load the magazine ensuring that cartridges are pushed all the way to the rear of the magazine (**FIGURE 5**). Load no more than 5 rounds.

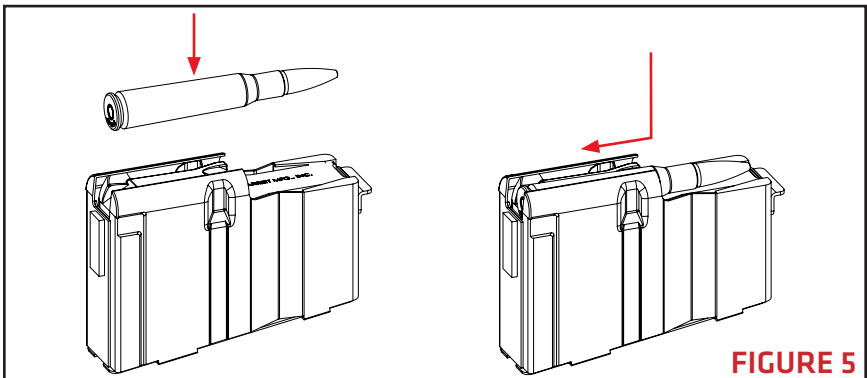

2. Ensure the safety lever is in the “S” (safe) position.
3. With the rifle pointed in a safe direction, lift the bolt handle (**FIGURE 6-A**) and pull it completely to the rear (**FIGURE 6-B**).

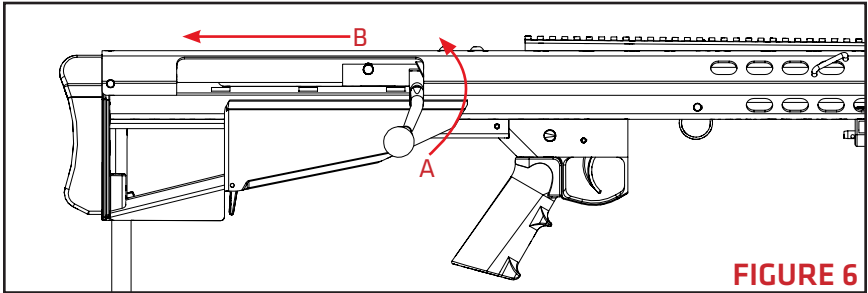

4. Insert the magazine into the magazine well in the lower receiver, with magazine tilted at approximately a 45° angle (bullet tips upward). Insert the front of the magazine hook to its hinge, located in the front of the magazine well (**FIGURE 7-A**). Swing the rear of the magazine up until it locks into place by means of the magazine catch (**FIGURE 7-B**). It should lock in with an audible click. Tug down on the magazine to ensure it is properly seated.

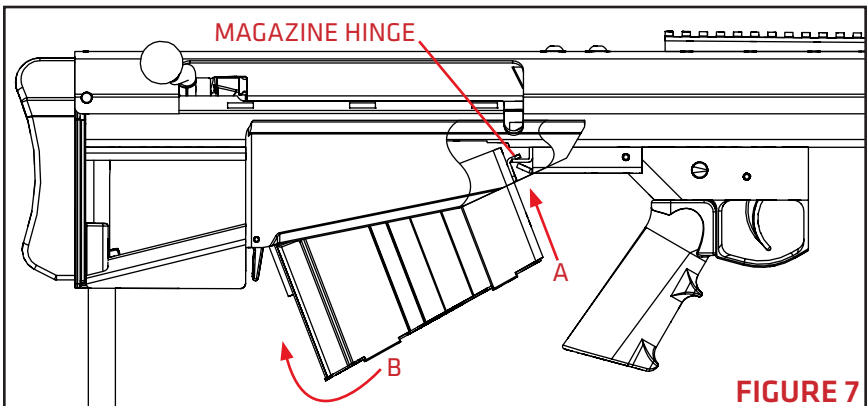

NOTE: THE BOLT MAY BE FORWARD OR REARWARD DURING MAGAZINE INSERTION.

5. Push the bolt handle fully forward (**FIGURE 8-A**) and then downward (**FIGURE 8-B**).

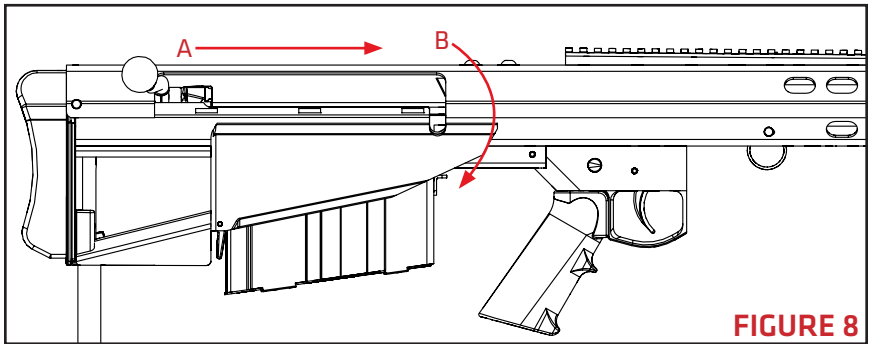

⚠ WARNING

DO NOT ATTEMPT TO FORCE A CARTRIDGE INTO THE CHAMBER BY FORCING THE BOLT CLOSED. IF THE BOLT WILL NOT CLOSE EASILY, REMOVE THE CARTRIDGE AND EXAMINE IT FOR DAMAGE OR DEFECTS. CHECK THE CHAMBER FOR OBSTRUCTIONS.

6. Rotate the safety lever forward to the fire position to disengage the safety. The rifle is now able to fire.
7. Pulling the trigger will fire one (1) cartridge.

⚠ WARNING

DOUBLE HEARING PROTECTION SHOULD BE WORN WHEN FIRING SINCE HARMFUL LEVELS OF NOISE ARE GENERATED.

⚠ WARNING

THE SHOOTER MUST BE POSITIONED DIRECTLY BEHIND THE RIFLE WITH THE RECOIL PAD HELD FIRMLY AGAINST THE SHOULDER. FIRING THE RIFLE IN ANY OTHER POSITION COULD RESULT IN INJURY BY CONTACT WITH THE RIFLE OR RIFLE SCOPE.

CYCLING THE ACTION

To cycle the action after firing, lift the bolt handle up, then pull it fully to the rear. This action will extract the spent cartridge casing from the chamber and eject it from the rifle. Return the bolt to the forward position to load another cartridge from the magazine and enable the rifle to fire again. You may repeat this procedure until the magazine is empty or return safety lever to the “S” (safe) position until ready to fire again.

⚠ WARNING

RECENTLY FIRED BRASS MAY BE VERY HOT

UNLOADING AND CLEARING

1. Place the safety lever in the “S” (safe) position.
2. Lift the bolt handle upward and pull it to the rear to eject a chambered cartridge or spent cartridge casing.
3. Press the magazine catch and remove the magazine by pivoting it down and out (**FIGURE 9**).

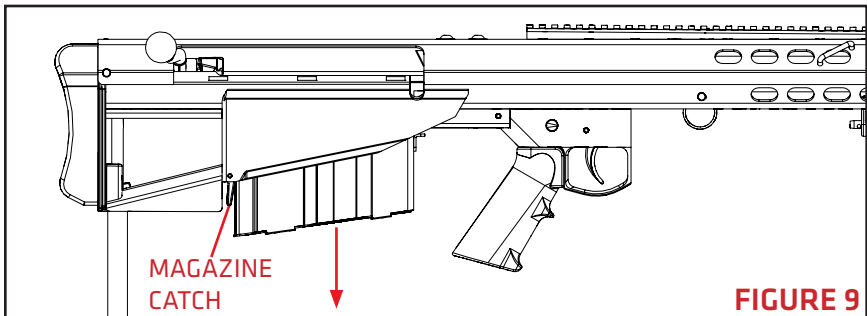

4. Visually and physically check the chamber to ensure there is no ammunition present.

UNLOADING MAGAZINE

1. Hold the magazine in either the right or left hand, cartridges facing away from you.
2. Using the thumb of the other hand, push the cartridges forward and out one after another, until all are ejected.

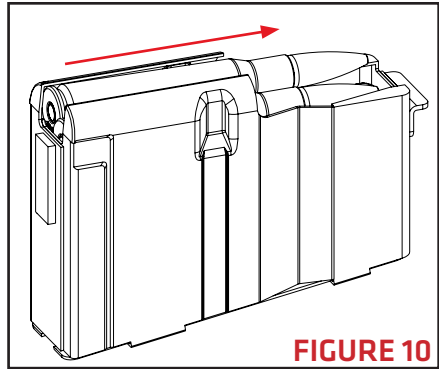

FIGURE 10

DISASSEMBLY AND ASSEMBLY

⚠ WARNING

UNLOAD THE RIFLE BEFORE DISASSEMBLY. ENSURE THAT LIVE AMMUNITION IS NOT PRESENT DURING DISASSEMBLY OR ASSEMBLY.

DISASSEMBLY AND ASSEMBLY OF MAJOR COMPONENTS

1. Lower the bipod legs to allow the rifle to rest on the bipod feet and buttplate assembly.
2. Ensure the magazine is removed, bolt is retracted fully to the rear, and the chamber is clear of any ammunition.
3. Remove the front (**FIGURE 11-A**) and rear (**FIGURE 11-B**) lock pins from the receivers.

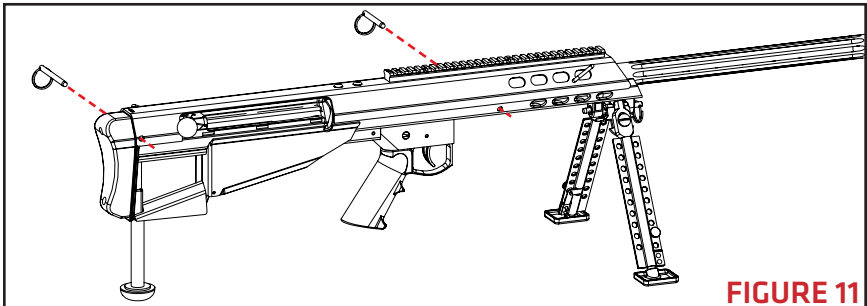
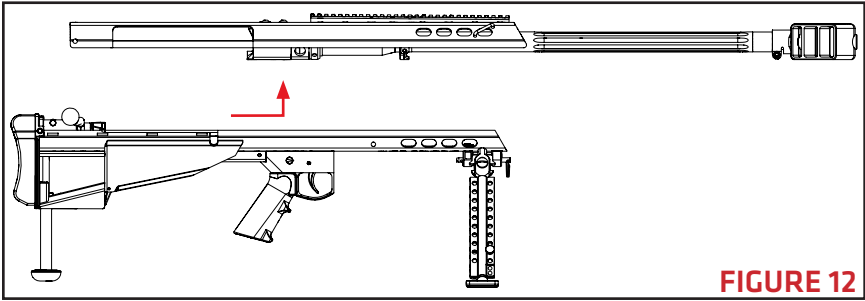

FIGURE 11

4. Slide the upper receiver and barrel forward about 1/2 an inch (13mm) then lift to separate the two receivers (**FIGURE 12**)

**FIGURE 12**

NOTE: NO FURTHER DISASSEMBLY OF THE UPPER RECEIVER IS NECESSARY.

5. Place the safety lever on the “F” (fire) position, pull the trigger, then slide the bolt carrier forward and lift it off the rails (**FIGURE 12**).

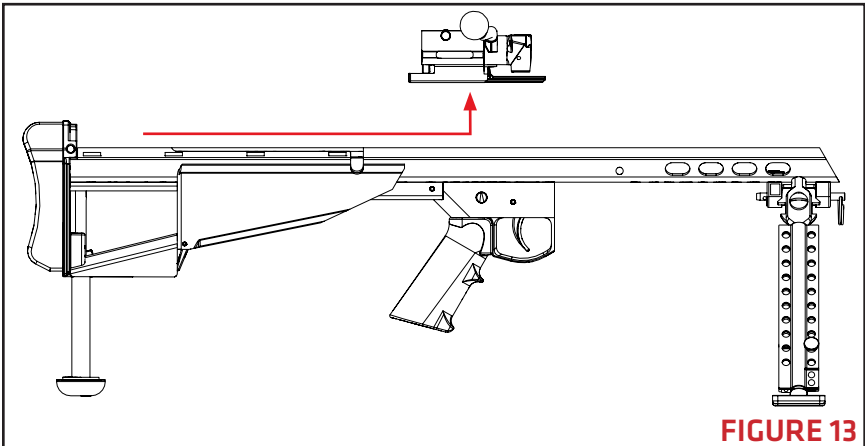
**FIGURE 13**

6. Reassembly is the reverse of disassembly.

⚠ CAUTION

DO NOT ATTEMPT TO FUNCTION CHECK THE TRIGGER AND COCKING PIECE ASSEMBLY WITHOUT THE UPPER AND LOWER RECEIVER COMPLETELY ASSEMBLED. DOING SO MAY CAUSE DAMAGE TO THE COCKING PIECE.

DISASSEMBLY AND ASSEMBLY OF THE BOLT CARRIER

1. De-cock the action by lowering the bolt handle (**FIGURE 14**)

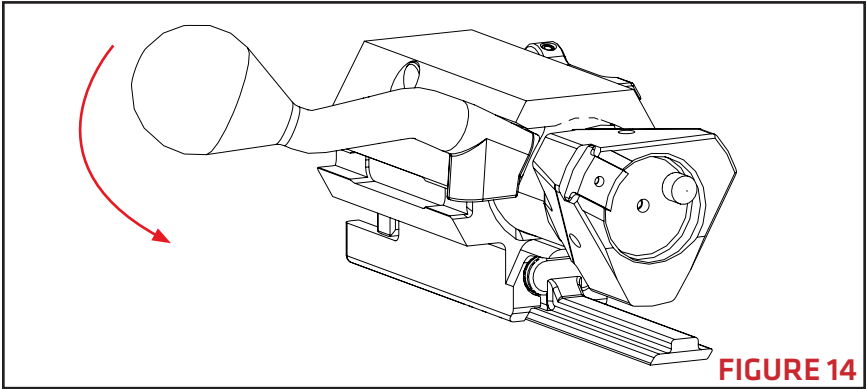

2. While compressing the bolt into the bolt carrier (**FIGURE 15-A**), rotate the bolt pin lever (**FIGURE 15-B**). Slowly allow the bolt to return to the forward position.

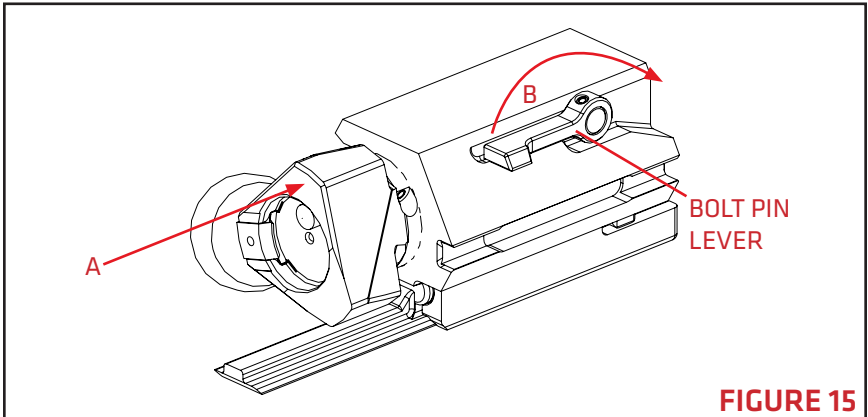

3. Remove the bolt from the bolt carrier assembly.
4. Pivot the cocking piece so that the spring retainer clears the bolt carrier (**FIGURE 16-A**) then remove it from the rear of the bolt carrier (**FIGURE 16-B**)

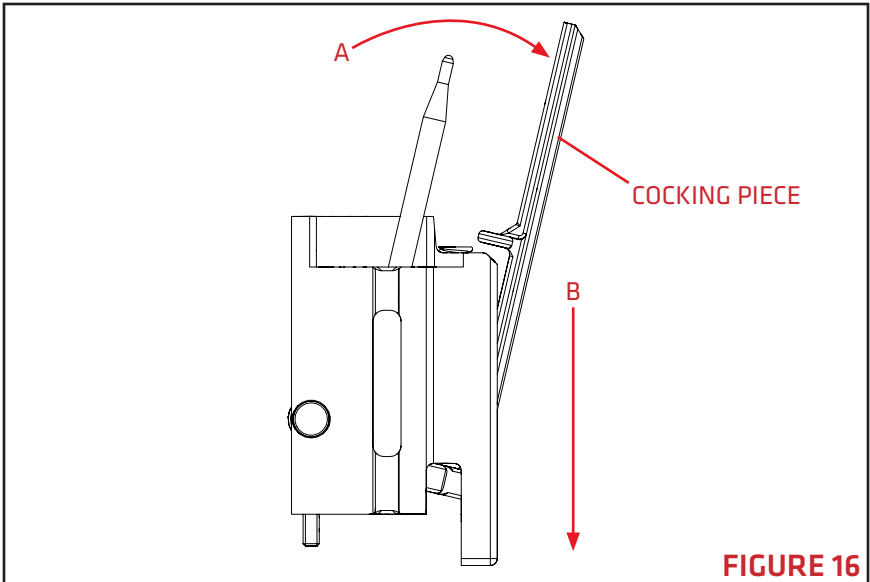

5. Removal of the firing pin from the cocking piece is not necessary as long as the firing pin is freely pivoting on its retaining pin. Ensure the firing pin can move freely about 3/4 inch (20mm) (**FIGURE 17**).

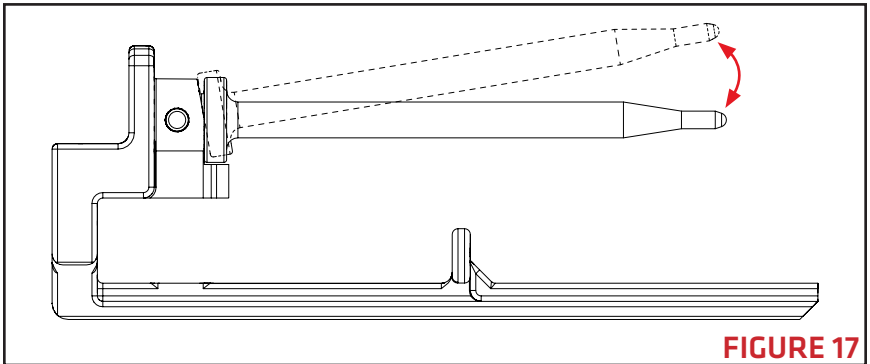

6. Remove the two firing springs from inside the bolt carrier (**FIGURE 18**).

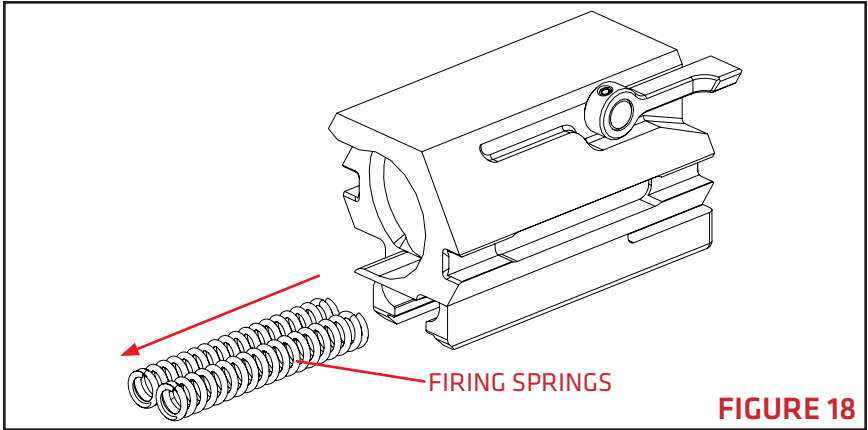

NOTE: NO FURTHER DISASSEMBLY OF THE BOLT CARRIER IS NECESSARY.

7. Reassembly of the bolt carrier is reverse of the disassembly.

REMOVAL AND INSTALLATION OF THE EXTRACTOR

NOTE: REMOVAL OF THE EXTRACTOR IS NOT NECESSARY FOR ROUTINE MAINTENANCE. THE REMOVAL IS TO FACILITATE PARTS REPLACEMENT ONLY.

1. To remove the extractor, depress the extractor plunger by inserting a 1/16 inch (1.5mm) pin punch through the extractor hole (**FIGURE 19-A**). While depressing the plunger, slide the extractor away from the firing pin hole (**FIGURE 19-B**).

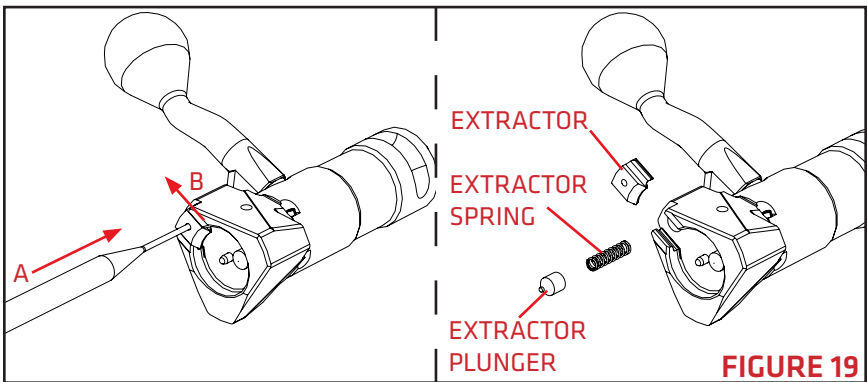

⚠ WARNING

THE EXTRACTOR IS UNDER SPRING PRESSURE AND IS HELD IN PLACE BY THE EXTRACTOR PLUNGER. WEAR SAFETY GLASSES WHEN REMOVING/INSTALLING THE EJECTOR PIN.

2. Re-installation of the extractor is reverse of the removal process.

REMOVAL AND INSTALLATION OF THE EJECTOR

NOTE: REMOVAL OF THE EJECTOR IS NOT NECESSARY FOR ROUTINE MAINTENANCE. THE REMOVAL IS TO FACILITATE PARTS REPLACEMENT ONLY.

1. Using a 3/32 inch (2.5mm) punch, drive the ejector pin out of the bolt (**FIGURE 20**).

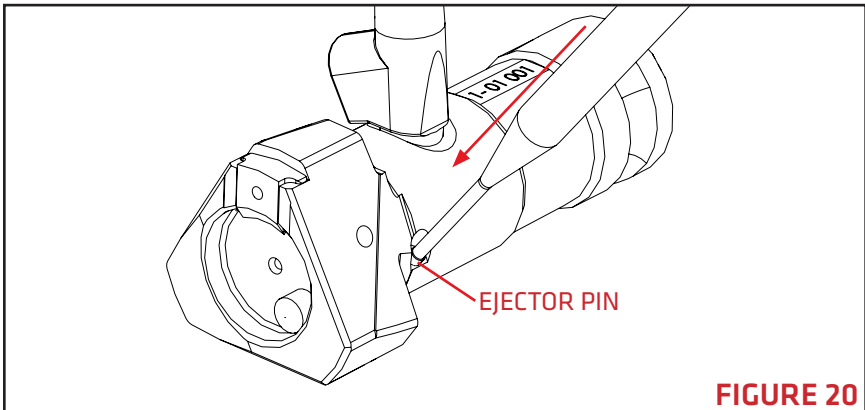
**⚠ WARNING**

THE EJECTOR IS UNDER SPRING PRESSURE AND IS HELD IN PLACE BY THE EJECTOR PIN. WEAR SAFETY GLASSES WHEN REMOVING/INSTALLING THE EJECTOR PIN.

2. Hold the bolt face firmly against a flat work surface and slowly remove the 3/32 punch from the ejector pin hole. The ejector and ejector spring will escape from the bolt after the punch is retracted from the ejector pin hole. Lift the bolt from the work surface and remove the ejector and ejector spring (**FIGURE 21**).

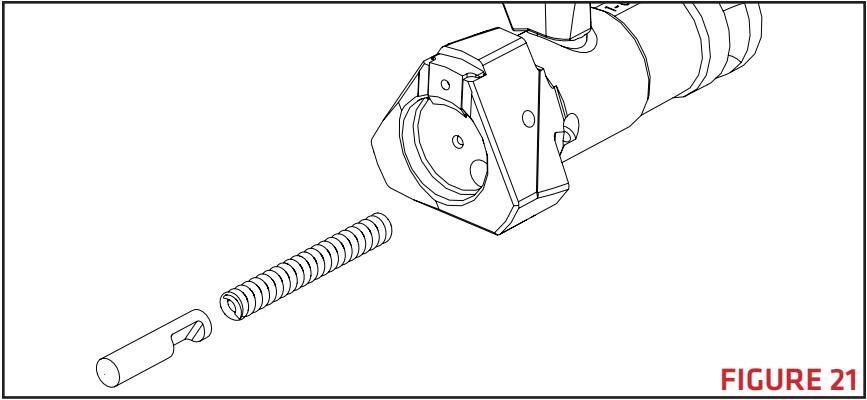

3. To install the ejector, ensure the extractor is installed and insert the ejector spring and ejector into the bolt. Orient the ejector so that the ejector's pin slot is facing away from the bolt (**FIGURE 21**).
4. Hook the rim of a cartridge casing under the extractor. Pivot the casing to force the ejector flush with the bolt face (**FIGURE 22-A**) and insert a 3/32 inch (2.5mm) punch into the ejector pin hole (**FIGURE 22-B**).

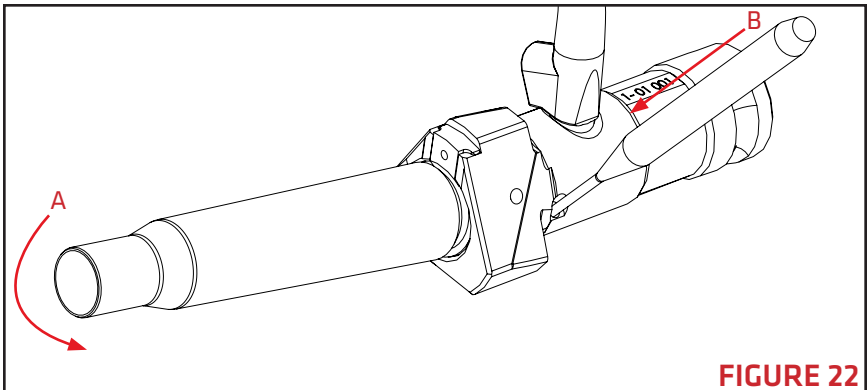

5. As the punch holds the ejector in place, start the ejector pin from the opposite side until the pin holds the ejector instead of the punch. Use the 3/32 inch (2.5mm) punch to finish driving the ejector pin until it is flush with the bolt.

CLEANING AND LUBRICATION

WARNING

**UNLOAD AND CLEAR THE RIFLE BEFORE CLEANING.
ENSURE NO LIVE AMMUNITION IS PRESENT DURING THE
CLEANING AND LUBRICATION PROCESS.**

CAUTION

**DO NOT INSERT CLEANING RODS THROUGH THE MUZZLE.
THE BARREL CROWN COULD BE DAMAGED WHICH WOULD
SEVERELY DEGRADE THE ACCURACY OF THE RIFLE.**

1. The rifle should be cleaned and lubricated after each shooting session.
2. Apply cleaning solvent to a chamber brush and clean the chamber. Barrett Heavy Bore Cleaner is recommended.
3. Apply cleaning solvent to a bore brush and clean the bore. Barrett Heavy Bore Cleaner is recommended.
4. Clean the muzzle brake with a stiff plastic brush and bore solvent. It is best to clean the muzzle brake at the same time the barrel is being cleaned as the bore solvent will help loosen the carbon build-up on its interior walls.
5. Clean the bolt face with bore solvent. Use a stiff plastic brush to remove carbon from both the extractor and the ejector. Depress the ejector and extractor by hand to test for smooth function.
6. Use dry patches as necessary to remove cleaner from the bore and chamber.
7. Clean the remainder of the rifle with cotton-tipped swabs, general-purpose brushes and rags. Make sure all metal surfaces are coated with light preservative oil.

8. Lubricate the critical surfaces of the bolt, bolt carrier, and lower receiver assembly (**FIGURE 23**).

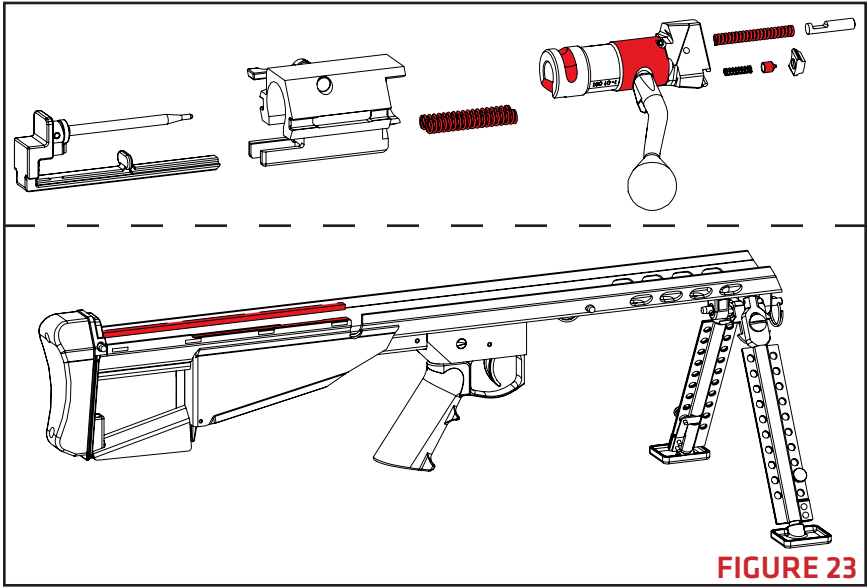

GENERAL MAINTENANCE

⚠ WARNING

TO PROTECT THE RIFLE FROM CORROSION, THE RIFLE AND THE INTERIOR OF THE CARRYING CASE SHOULD BE MOISTURE FREE BEFORE THE RIFLE IS PLACED IN THE CARRYING CASE FOR STORAGE.

1. Ensure that all bearing surfaces and exposed parts, particularly those listed below, are clean and properly lubricated:
 - Barrel
 - Bolt and bolt carrier
 - Trigger assembly

2. Inspect all parts for looseness and tighten or replace, as necessary.
 - Inspect all parts (especially along welds) for cracks or damage and replace, if necessary.
 - Each time the rifle is assembled for firing ensure that the

barrel, chamber, and locking lugs of the bolt are free of excess oil. When possible, an operational check using ten dummy rounds should be performed. Insert the dummy rounds into a magazine and load the magazine into the rifle. Manually operate the bolt to the rear and forward, making sure the cartridges feed, extract, and eject properly. If the rifle is not functioning correctly, refer to the Troubleshooting section.

- Refer to the **TROUBLESHOOTING** section for Malfunction and Immediate Action Troubleshooting.
3. The magazine, chamber/bore, and firing pin channel should be free of cleaner, oil, grease, or other lubrication prior to use.

CORROSIVE AMMUNITION CLEANING PROCEDURE

⚠ CAUTION

BARRETT DOES NOT RECOMMEND SHOOTING CORROSIVE AMMUNITION. SHOOTING CORROSIVE AMMUNITION MAY DAMAGE YOUR FIREARM. DAMAGE DUE TO FIRING CORROSIVE AMMUNITION IS EASY TO DETECT AND IS NOT COVERED UNDER THE WARRANTY AGREEMENT.

If you have been forced by necessity or have accidentally fired corrosive ammunition, the following specialized cleaning procedure applies.

1. **Cleaning.** Immediately after firing the corrosive ammunition, thoroughly scrub the bore and bolt face with very hot soapy water or cleaner specifically designed for corrosive ammunition.
2. **Rinsing and drying.** When the metal is clean, rinse the surfaces with very hot water. Wipe off excess moisture. The residual heat in the metal will evaporate most water droplets.
3. **Protecting.** Either continue cleaning the rifle using procedures specified for non-corrosive ammunition, or if temporary transportation or storage is necessary, immediately coat all surfaces with rust preventative.

TROUBLESHOOTING

MALFUNCTION	CAUSE	CORRECTIVE ACTION
FAILURE TO FEED	Check Magazine: a. Proper Installation b. Dirt/Debris c. Damage	a. Reinstall magazine into the receiver b. Clean magazine c. Replace magazine
FAILURE TO CHAMBER	Check cartridge for damage	Remove damaged round
	Check for dirty chamber	Clear and clean chamber
FAILURE TO FIRE	Faulty ammunition	Replace ammunition
	Cocking piece shroud not properly installed in bolt	Assemble properly
	Cocking piece is dragging	Clean and lubricate cocking piece
	Firing pin or firing pin spring is broken or damaged	Please contact Tech Support
FAILURE TO EXTRACT	Broken or worn extractor	Replace extractor
	Broken or worn extractor spring	Replace extractor spring
	Extractor not moving freely	Clean extractor, extractor spring and recess
	Dirty ammunition or chamber	Clean chamber and ensure ammunition is clean
	Broken case rim	Clear with cleaning rod

MALFUNCTION	CAUSE	CORRECTIVE ACTION
FAILURE TO EJECT	Broken or worn ejector	Replace ejector
	Broken or worn ejector spring	Replace ejector spring
	Ejector not moving freely	Clean ejector, ejector spring, and recess
VERY HARD RECOIL	Check for faulty/hot ammunition	Replace or cool ammunition
	Improper shooting position	Firmly shoulder the buttstock
	Check for loose, missing, damaged/clogged muzzle brake	Please contact Tech Support

EXPLODED VIEW

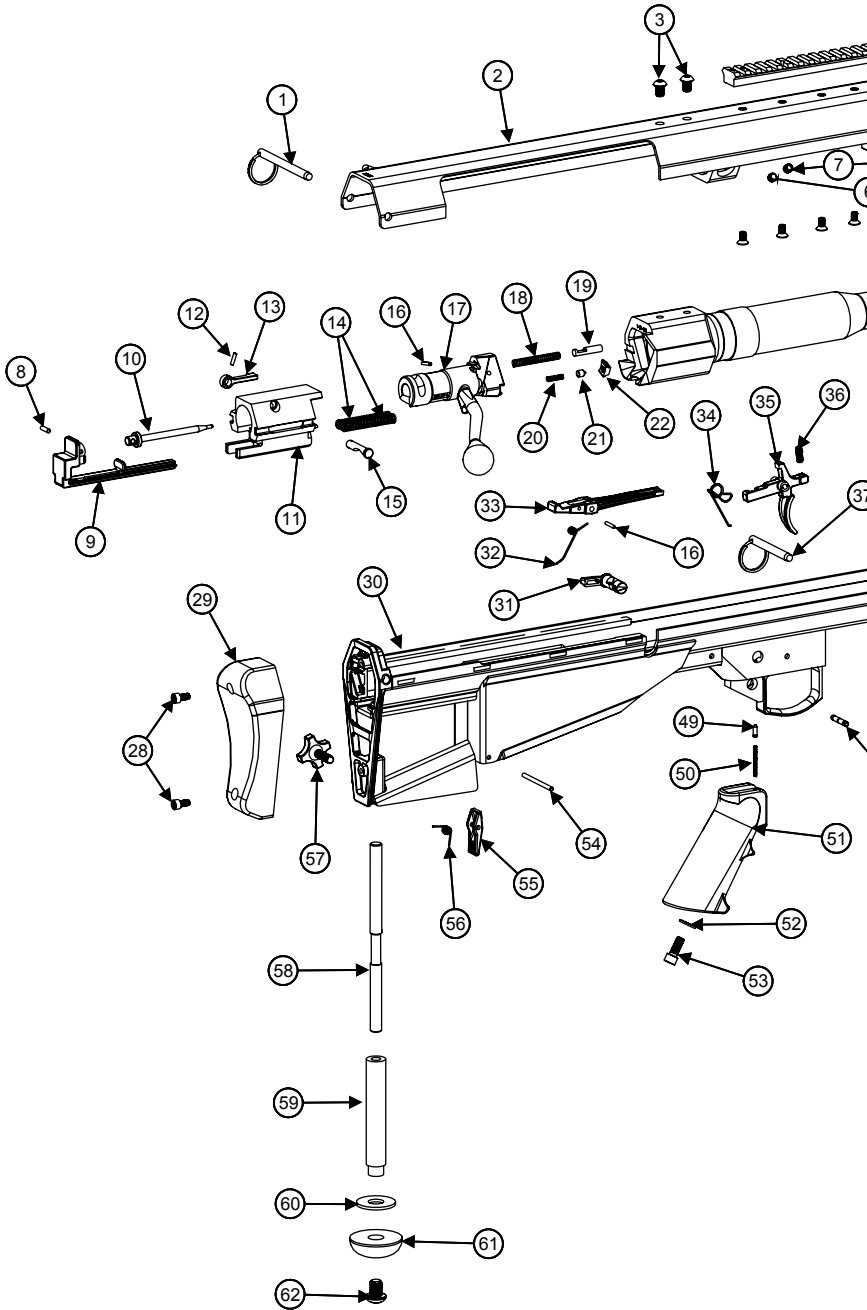

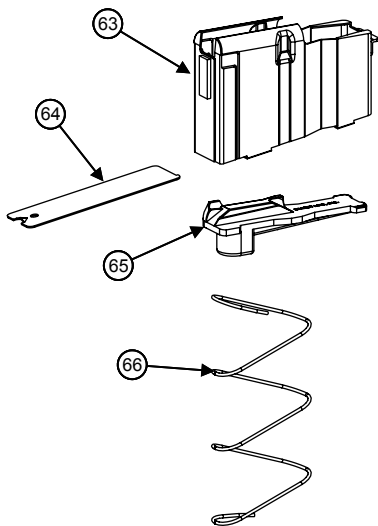
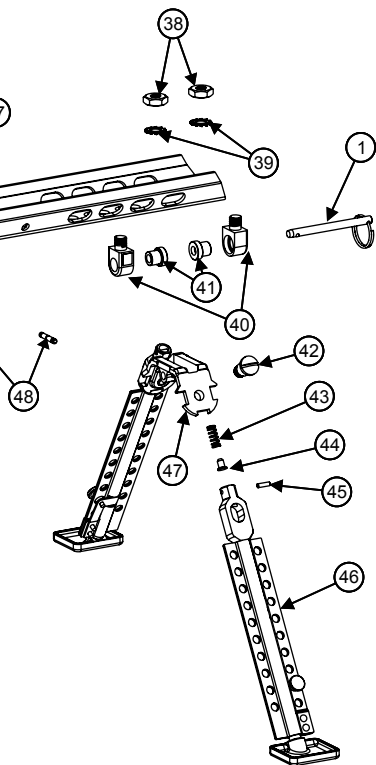
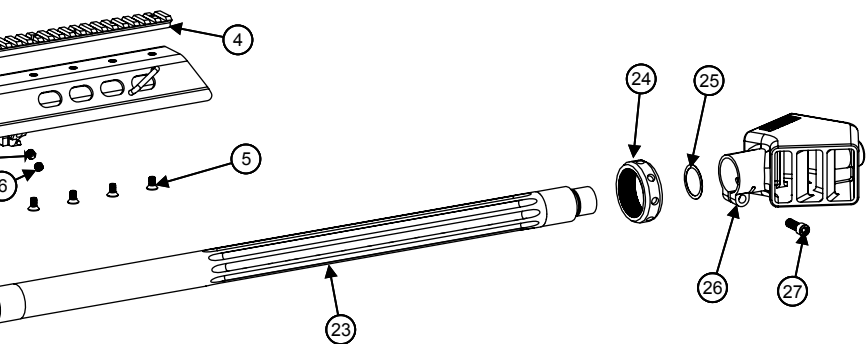

PARTS LIST

PART NO.	DESCRIPTION	QTY.
1	Rear Lock Pin	2
2	Upper Receiver	1
3	Barrel Extension Screw	2
4	Elevated Scope Base	1
5	Scope Base Screw	8
6	Barrel Screw	2
7	Barrel Screw	2
8	DP .125 x .4375	1
9	Cocking Piece	1
10	Firing Pin	1
11	Bolt Carrier	1
12	RP .093 x .375	1
13	Bolt Pin Lever	1
14	Firing Spring	2
15	Bolt Pin	1
16	Cam Pin Pin	2
17	Bolt	1
18	Ejector Spring	1
19	Ejector	1
20	Extractor Spring	1
21	Extractor Plunger	1
22	Extractor	1
23	Barrel Complete	1
24	Barrel Lock Nut	1
25	Muzzle Brake Shim	1
26	Muzzle Brake	1
27	Muzzle Brake Screw	1
28	Recoil Pad Screw	2
29	Recoil Pad	1
30	Lower Receiver	1
31	Safety	1
32	Sear Spring	1
33	Sear	1

PART NO.	DESCRIPTION	QTY.
34	Trigger Spring	1
35	Trigger	1
36	Trigger Overtravel Screw	1
37	Front Lock Pin	1
38	Yoke Mount Nut	2
39	Yoke Mount Washer	2
40	Yoke Mount	2
41	Bipod Shim Bushing	2
42	Bipod Screw	2
43	Bipod Spring	2
44	Bipod Detent	2
45	Bipod Pin	2
46	Bipod Leg Complete	2
47	Bipod Yoke	1
48	Trigger Housing Pin	2
49	Safety Detent	1
50	Safety Spring	1
51	Pistol Grip	1
52	Pistol Grip Stock Washer	1
53	Pistol Grip Screw	1
54	Magazine Catch Pin	1
55	Magazine Catch	1
56	Magazine Catch Spring	1
57	Monopod Lock Knob	1
58	Monopod Elevation Screw	1
59	Elevation Collar	1
60	Monopod Foot Washer	1
61	Monopod Foot	1
62	Monopod Screw	1
63	Magazine Complete	1
64	Magazine Floor Plate	1
65	Magazine Follower	1
66	Magazine Spring	1



P.O. Box 1077
Murfreesboro, TN 37133 USA
615.896.2938
615.896.7313 fax
barrett.net