

In the event that you should require service for your Nikon RIFLESCOPE,
in case of USA market, please send it directly to:
Nikon Scope Service
841 Apollo Street, Suite 100
El Segundo, CA. 90245-4721
1-800-Nikon SV.
In other market, please bring it to dealer from which you purchased it.

Manufacturer: **NIKON VISION CO., LTD.**
3-25, Futaba 1-chome, Shinagawa-ku, Tokyo 142-0043, Japan

Nikon

PROSTAFF  **Riflescope**

CUSTOM
XR
TURRET

3.5-14×40 SF **3.5-14×50 SF** **4.5-18×40 SF**

Instruction manual

Printed in the Philippines (781C)1E/1309

En

TABLE OF CONTENTS

1. Introduction.....	3
2. Nomenclature	5
3. Specifications	7
4. Instructions	8
5. Obtaining and changing the custom XR turret.....	13

1. Introduction

Congratulations on your choice of a Nikon PROSTAFF 5 Riflescope. Your new scope is the finest example of Nikon's rugged and durable construction and precision bright optics; important qualities for a serious shooter's riflescope.

Whether you use your scope for hunting or for target shooting, the procedure for mounting is identical. A set of high-quality steel mounting rings which have a standard diameter of 25.4 mm (1 in) are required to mount the scope. Follow the ring manufacturer's instructions for mounting procedures. After mounting the scope on your rifle, follow the procedures for reticle alignment.

About the Custom XR Turret

The Custom XR Turret provides simplicity in long range shooting by providing an elevation turret engraved to match the ballistics of your cartridge, allowing you to dial the distance to the target. Bullet Drop Compensation is now as simple as dialing the distance on your turret, eliminating the need to hold over your target for long shots.

IMPORTANT INFORMATION

IT IS IMPORTANT THAT YOUR NIKON RIFLESCOPE IS MOUNTED PROPERLY AND THAT CAREFUL CONSIDERATION BE GIVEN WHEN MOUNTING YOUR NIKON RIFLESCOPE ON A FIREARM. WE HIGHLY RECOMMEND THAT YOUR NIKON RIFLESCOPE BE MOUNTED ON YOUR FIREARM BY AN EXPERIENCED, REPUTABLE GUNSMITH. THE USER ASSUMES ALL RESPONSIBILITY AND LIABILITY FOR HAVING THE NIKON RIFLESCOPE PROPERLY MOUNTED TO A FIREARM AND USING THE NIKON RIFLESCOPE PROPERLY. ALWAYS CHECK THE CONDITION OF YOUR MOUNTING SYSTEM PRIOR TO USING YOUR FIREARM.

SUPPLIED ITEM(S)

Body.....	1 piece	High profile Windage adjustment turret (4.5-18×40 SF only).....	1 piece	Hex key for Custom XR Turret (1.3mm)	1 piece
Eyepiece cap.....	1 pair	High profile Windage adjustment turret cap (4.5-18×40 SF only)	1 piece	Hex key for Windage adjustment turret (2mm) (4.5-18×40 SF only)	1 piece
Objective cap.....	1 pair	Sunshade (4.5-18×40 SF only)	1 piece		

Caution

(1) Do NOT look at the sun through the riflescope. It will permanently damage your eye. This precaution applies to all optical devices, such as cameras and binoculars.

(2) The riflescope is effectively sealed against moisture and dust. You may use your scope safely either in the rain or in dusty climates. To preserve the appearance of the scope, we recommend that it be dried and cleaned prior to storage. Use a soft cloth for cleaning metal surfaces and use photographic lens tissue to clean the scope's lenses.

When setting the reticle for hunting, you should determine your standard range and then adjust the reticle based upon that target distance. For targets which vary from that standard distance, according to personal preference, you may simply adjust the position of the reticle in relation to your target, or you may wish to use the procedure for trajectory compensation.

We hope that you will enjoy your new Nikon PROSTAFF 5 Riflescope for many years to come. Enjoy using it, and above all, always follow safe shooting procedures.

N.B. Export of the products* in this manual may be controlled under the laws and relatives of the exporting country. Appropriate export procedure, such as obtaining of export license, shall be required in case of export.

*Products: Hardware and its technical information (including software)

2. Nomenclature

3.5-14×40 SF
3.5-14×50 SF

4.5-18×40 SF

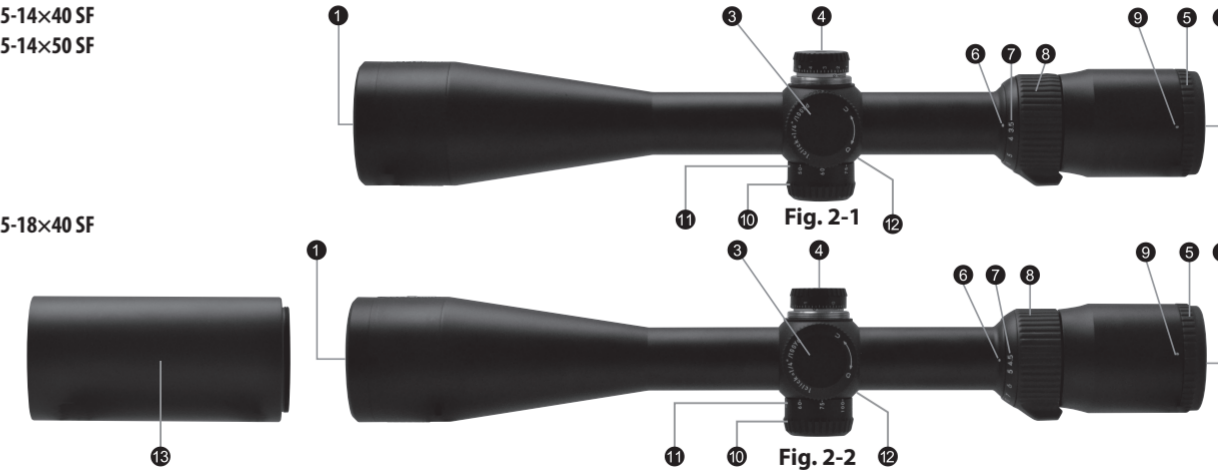

- 1 Objective lens
- 2 Eyepiece lens
- 3 Elevation adjustment turret
- 4 Windage adjustment turret
- 5 Eyepiece adjustment
- 6 Power index
- 7 Power scale
- 8 Power selector ring
- 9 Diopter index dot
- 10 Side focus adjustment turret
- 11 Distance scale
- 12 Distance index
- 13 Sunshade

Elevation adjustment



Fig. 2-3

Windage adjustment

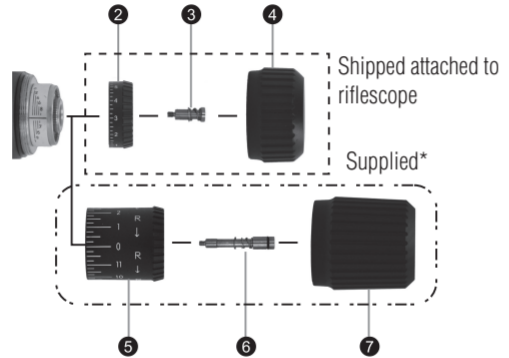

Fig. 2-4

- ① Elevation turret
- ② Low profile turret
- ③ Screw for low profile turret
- ④ Cap for low profile turret
- ⑤ High profile windage adjustment turret
- ⑥ Screw for high profile windage adjustment turret
- ⑦ Cap for high profile windage adjustment turret

* 4.5-18x40 SF Only

3. Specifications

Model		3.5-14x40 SF	3.5-14x50 SF	4.5-18x40 SF
Actual Magnification		3.5-14x	3.5-14x	4.5-18x
Objective Diameter	(mm)	40	50	40
Exit Pupil*	(mm)	2.9	3.6	2.2
Eye Relief**	(mm) (in)	97-97 4.0-4.0	97-97 4.0-4.0	97-97 4.0-4.0
Tube Diameter	(mm) (in)	25.4 1	25.4 1	25.4 1
Objective Tube Diameter	(mm) (in)	50.3 1.98	60.3 2.37	50.3 1.98
Outside Diameter of Eyepiece	(mm) (in)	44 1.73	44 1.73	44 1.73
Adjustment Graduation	***(MOA)	1 click=1/4"	1 click=1/4"	1 click=1/4"
Max Internal Adjustment (Elevation & Windage)	***(MOA)	55	55	40
Parallax Setting	(m) (yd)	45.72-∞ 50-∞	45.72-∞ 50-∞	45.72-∞ 50-∞
Field of View at 100 m/yds**	(m) (ft)	9.5-2.4 28.6-7.2	9.5-2.4 28.6-7.2	7.5-1.9 22.4-5.6
Length	(mm) (in)	345 13.6	364 14.3	345 13.6
Weight	(g) (oz)	515 18.2	575 20.3	510 18.0

*at maximum magnification **at minimum magnification)-(at maximum magnification) ***MOA = Minute of Angle

4. Instructions

(1) Focusing

- ① Look through the eyepiece with your eye positioned about 10 cm (4 in) away from the eyepiece to see the Duplex reticle (Fig. 4-1). Be sure your eye is positioned with proper alignment and with proper eye relief, otherwise the view will “black out.”
- ② Point the objective end of the scope at the sky (NOT point it at the sun) or at a plain unpatterned wall.
- ③ Turn the eyepiece adjustment counter-clockwise and then turn it clockwise until the reticle appears sharp.

(2) Magnification

- The PROSTAFF 5 Riflescope has variable magnification. For details, see “3. Specifications”.
To change powers, rotate the power selector ring until the desired magnification appears adjacent to the power index dot.

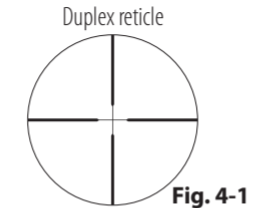

Fig. 4-1

(3) Adjustment of the riflescope

Sighting through the riflescope, align the rifle with your aiming point on the target and shoot a trial round. If the bullet does not hit the aiming point, adjust the elevation and windage as follows:

- If the bullet hits under the aiming point, turn the elevation adjustment turret (counter-clockwise) in the direction of the arrow marked “U” for up. If the bullet hits high, turn the elevation adjustment turret (clockwise) in the direction of the arrow marked “D” for down.
- If the bullet hits to the right of the aiming point, turn the windage adjustment turret (clockwise) in the direction of the arrow marked “L” for left. If the bullet hits to the left of the aiming point, turn the windage adjustment turret (counter-clockwise) in the direction of the arrow marked “R” for right.
- For the high profile windage adjustment turret, adjustment is made by turning the turret by hand. If the bullet hits under the aiming point, turn the turret in the direction of the arrow marked “U”. If the bullet hits to the left of the aiming point, turn the turret in the direction of the arrow marked “R”.
- After the reticle has been adjusted to the point of impact, replace the turret cap for both the windage and elevation adjustment turrets.

(4) Zero setting of adjustment turrets

The elevation adjustment and windage adjustment turrets have a retracting system. After the reticle has been adjusted to the point of impact, pull out the elevation adjustment or windage adjustment turret.

The turret can now be turned freely. Align the zero number to the index line to set the zero setting, and then release the turret. The turret automatically retracts to the original position.

(5) Changing the windage adjustment turret*

Remove the turret cap by turning it counter-clockwise. Align the turret to the 0 (zero) position of the scale ring. This is to assure that the scale ring will be correctly aligned to the new turret. (The alignment position should be remembered.)

With the turret held with your fingers to avoid shifting of the aligned scale ring, turn the screw in the top of the turret counter-clockwise with the supplied hex key for windage adjustment turret (2mm) (1) until the screw comes out. Then remove the turret (Fig. 4-2).

Insert the new turret into position and align the scale ring to 0.

Insert the screw. By securing the turret with your fingers to avoid shifting of the scale ring, turn the screw clockwise with the supplied hex key, until the turret is firmly secured.

*Please refer to "Supplied Item(s)" to see if your riflescope is provided with high profile windage adjustment turrets.

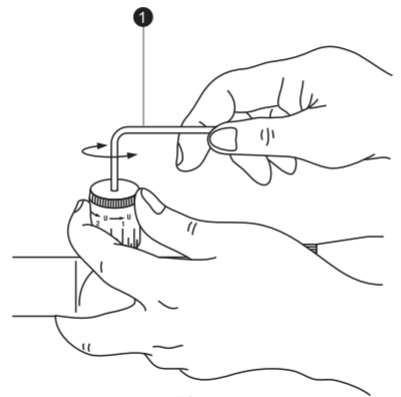

Fig. 4-2

(6) Adjustable side focus

The PROSTAFF 5 Riflescope 3.5-14×40 SF, 3.5-14×50 SF, and 4.5-18×40 SF can be more precisely focused within the range of at least 45.72 m (50 yd) to infinity by rotating the side focus adjustment. Parallax can be eliminated and sight alignment will be accurate.

Use its distance scale as a reference guide.

Note:

- The windage and elevation scales of the PROSTAFF 5 Rifle scope 3.5-14×40 SF, 3.5-14×50 SF, and 4.5-18×40 SF are calibrated in divisions of 1/4 minute of angle with a click at intervals of 1/4 minute of angle (1 division).
- When adjusting the reticle to the point of aim, remember that 1 minute of angle equals approximately 2.54 cm (1 in) at 91.44 m (100 yd). Therefore, if the impact point is 5.08 cm (2 in) low and 2.54 cm (1 in) right at 91.44 m (100 yd) Parallax Setting, you should adjust 2 minutes of angle up and 1 minute of angle left. In the case of 45.72 m (50 yd) Parallax Setting, the adjusting value is 2×. In the case of 68.58 m (75 yd) Parallax Setting, the adjusting value is 1.5×.

5. Obtaining and changing the custom XR turret**(1) Obtaining the Custom XR Turret**

Please see the voucher included in the display box for details to redeem your Custom XR Turret. Please note the rifle scope can be used with the existing turret should you choose not to redeem the Custom XR Turret.

(2) Changing the Custom XR Turret

We recommend that you zero the rifle scope with the existing turret as it is marked with graduations for each click value. Then follow the directions below to install your Custom XR Turret.

- ① Using the supplied hex key for Custom XR Turret (1.3mm) (1), loosen the three screws on the lateral face of the included turret by turning the key counter-clockwise (Fig. 5-1).
 - Be sure not to excessively loosen the screws. The screws may fall out.
 - Loosen the screws uniformly.
- ② Remove the turret.

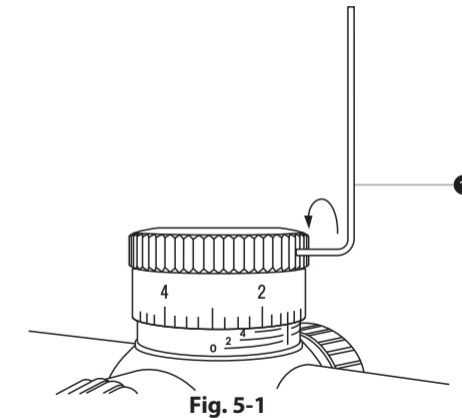
**Fig. 5-1**

- ③ Attach the Custom XR Turret.
 - The Custom XR Turret locks the turret in place so that you are unable to dial below the zero setting. Be sure to carefully align the Zero mark on the Custom XR Turret with the vertical index line on the turret housing as mentioned in Step ④.
- ④ Align the zero mark on the turret with the vertical index line on the turret housing (Fig. 5-2).
- ⑤ Tighten the three screws by turning the hex key clockwise. Firmly tighten the screws so that the turret is secure.
 - Tighten the screws uniformly.

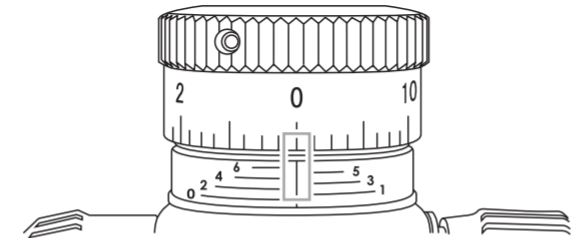

Fig. 5-2

Maintenance

(1) Lens cleaning

To remove dirt or fingerprints, soak gauze or lens cleaning paper (silicon-free paper sold at camera retailers) with a small quantity of absolute alcohol (available from drugstores) and lightly wipe off the affected areas.

Wiping with a handkerchief or leather may damage the lens surface and is not recommended.

Dust may scratch the lens surface or corrode the lens.

Brush dust off using a soft oil-free brush.

(2) Scope exterior

Use a soft dry cloth to wipe off any dirt or fingerprints that might accumulate.

It is not necessary to oil the scope's surface.

(3) Windage/elevation adjustments

These adjustments are permanently lubricated. Do not attempt to lubricate them. Cover them with the caps supplied, except when adjusting them, to keep out dust and dirt.

(4) Eyepiece adjustment

This adjustment is permanently lubricated. Do not attempt to lubricate it.

(5) Power selector ring

No lubrication is required for the power selector ring.

Do not pull up or remove the rubber covering on the power selector ring.

Waterproof models:

The riflescope is waterproof, and will suffer no damage to the optical system if submerged or dropped in water to a maximum depth of 1 m (3 ft 3 in) for up to 10 minutes.

The riflescope offers the following advantages:

- Can be used in conditions of high humidity, dust and rain without risk of damage.
- Nitrogen-filled design makes it resistant to condensation and mold.

Observe the following precautions when using the riflescope:

- The riflescope should not be operated nor held in running water.
- Any moisture should be wiped off before adjusting movable parts (adjustment turret, eyepiece, etc.) of the riflescope to prevent damage and for safety reasons.

To keep your riflescope in optimal condition, Nikon Vision recommends regular servicing by an authorized dealer.

Specifications and equipment are subject to change without any notice or obligation on the part of the manufacturer

Memo

Memo