

---

---

**CZ-USA SHOTGUN  
INSTRUCTION MANUAL**



**CZ-USA**  
**P.O. Box 171073**  
**Kansas City, KS 66117-0073**  
**Phone# 1-800-955-4486**  
**Fax# 913-321-4901**

## SAFETY INSTRUCTION

**Before handing the firearm read this manual carefully and observe the following safety instructions.**

Improper and careless handling of the firearm could result in unintentional discharge and could cause injury, death or damage to property. The same consequences can be caused by any unauthorized modifications or adjustments, corrosion, or use of non-standard or damaged ammunition. In these cases the manufacturer shall not be responsible in any manner whatsoever for the resultant consequences.

Before leaving the factory this firearm was tested, carefully inspected and packed. CZ cannot accept responsibility for product handling while in transit or upon leaving the factory. Please consider that the wooden parts of the shotgun are not under warranty. Therefore, please examine this firearm carefully at the time of purchase to ensure that it is unloaded and undamaged.

This instruction manual should always accompany the firearm, even in the case of its loan or sale.

Always follow the safety instructions for your safety and the safety of others.

1. Always handle your firearm as if it were loaded.
2. Never point your firearm at anything you do not intend to shoot.
3. Never take anyone's word that a gun is unloaded.
4. Always make sure that your firearm is not loaded before laying it down or handing it to another person.
5. Always store your firearm unloaded with the firing mechanism released.
6. Never abuse your firearm by using it for any purpose other than shooting.
7. Never leave a loaded firearm unattended.
8. Prior to loading the firearm make sure the barrel bore, chamber and action are clean and clear of obstructions. Clean a dirty firearm immediately so that it will function properly and safely.
9. Always use only clean, dry, original high quality commercially manufactured ammunition, which is appropriate to the gauge of your firearm.
10. Never drink alcoholic beverages or take during before or during shooting.
11. Always wear safety glasses and ear protection during shooting whenever possible.
12. Always keep the safety on when the shotgun is loaded with a cartridge in the chamber, until you are ready to fire. Keep firearm pointed in a safe direction when disengaging the safety.
13. Always keep clear and keep others clear of the ejection port.
14. Never squeeze the trigger or put your finger in the trigger guard until you are aiming at a target and ready to shoot.
15. Always be absolutely sure of your target, and the area behind it, before you squeeze the trigger.
16. Never shoot at a hard surface such as rock, or a liquid surface such as water.
17. Never fire your firearm near an animal unless it is trained to accept the noise.
18. Never indulge in "horseplay" while holding your firearms.
19. Failure to fire: always hold the firearm, keeping it pointed towards the target, or a safe open area and wait 30 seconds when the firearm fails to fire. If a hangfire (slow ignition) has occurred, the round will fire within 30 seconds. If the round does not fire, remove the magazine, eject the round and examine the primer; if the firing pin indent on the primer is light, or non-existent, have the firearm examined by a competent gunsmith.
20. Always make sure your firearm is not loaded before cleaning, storing or travelling.
21. Always keep and store your firearm and ammunition in separate locked receptacles out of reach and sight of children and untrained people.
22. Never alter any parts of your shotgun as the safety and proper function of your shotgun could be seriously compromised.
23. Always be aware that corrosion, use of damaged ammunition, dropping the rifle on hard surfaces or other "coarse treatment" could cause a damage you may not see. If something like this happens allow the firearms to be examined and tested by a competent gunsmith.



## ASSEMBLY



1- Pull the latch on the forearm that is mounted on the barrel.



2- Detach the forearm from the barrel.



3- Push the top lever fully to the right.



4- While keeping the top lever pushed to right install the barrel to the receiver with an approx 40 - degree angle as it is seen in the figure. Be sure the barrel is completely installed to the receiver otherwise shotgun will not close.



5- Be sure that ejectors properly installed in the receiver



6- By forcing the barrel upwards close the shotgun, be sure the barrel and receiver are properly aligned and top lever returns to slightly to the right of center. It is normal that the top lever does not return exactly to the center, this allows for wear.



7- Mount the forearm to the barrel as seen in the figure. Be sure the opening latch of forearm is completely closed.



8- Put the safety on by moving the safety switch to the rear position.

*Note: Disassemble your shotgun by reversing the assembly instruction.*

## USAGE



1- Opening your shotgun by pushing the top lever to the right while pushing the barrel downward.



2- MAKE SURE THE SAFETY IS ON. (Moved to rear "S" exposed) Install the suitable cartridges according to your shotgun's gauge and chamber length.



3- Close your shotgun. **WARNING: YOUR SHOTGUN IS NOW LOADED.** Move the safety to the forward position and pull the trigger to fire.



4- Barrel Selection (Single trigger models only) With safety on, move the selector located inside the safety to the right to fire the bottom barrel first. After firing the bottom barrel the top barrel will fire with another pull of the trigger.

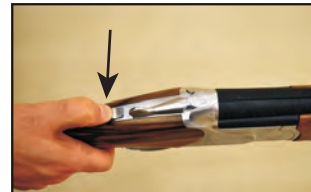

5- Barrel Selection (Single trigger models only) With safety on, move the selector located inside the safety to the left to fire the top barrel first. After firing the top barrel the bottom barrel will fire with another pull of the trigger.



6- After shooting open the shotgun by pushing the top lever fully to the right. Fired cartridges will be lifted for easy removal or ejected if your gun is fitted with automatic ejectors.



7- Mount the forearm to the barrel as seen in the figure. Be sure the opening latch of forearm is completely closed.



8- Put the safety on by moving the safety switch to the rear position.

## CHOKE TUBES



The choke constriction is designated by a series of notches at the muzzle end of the choke tube.  
**WARNING:** Never check the choke designation, install choke tubes or remove choke tubes unless the gun is unloaded and the action is open.

## DEFINITION AND THE USAGE OF CHOKE TUBES

Pattern With Lead Shot		Pattern With Steel Shot	Mark
★	Full	Not Recommended	
★★	Imp Mod	Not Recommended	
★★★	Mod	Full	
★ ★★★	Imp Cyl	Mod	
★★ ★★★	Cyl	Imp Cyl	

## MAINTENANCE



## Apply grease as shown

- ☒ Apply grease to all contact points between forend iron and receiver.
- ☒ Clean the barrel bore by passing a swab or cleaning patch through it to remove residue. If necessary, use a cleaning rod with a bore brush soaked in bore cleaning solvent.
- ☒ Run a clean dry cloth through the bore to remove excess residue
- ☒ Lightly oil the inside of the barrel with a clean patch coated with oil
- ☒ Apply a light coat of lubricant (preferably grease) to the connecting points of the receiver, barrels and forearm.
- ☒ Do not apply excess oil, grease or solvent. Excess cleaning fluids attract dirt, which can interfere with the function of the gun.
- ☒ Clean and lightly oil the external surface of the gun to remove any trace of dirt, moisture and fingerprints.

If you need further detailed maintenance contact a professional gunsmith.

## ASSEMBLY



1- Pull the latch on the forearm that mounted on the barrel.

2- Detach the forearm from the barrel.



3- Push the top lever fully to the right.

4- While keeping the top lever pushed to right install the barrel to the receiver with an approx 40 - degree angle as it is seen in the figure. Be sure the barrel is completely installed to the receiver otherwise shotgun will not close.



5- Mount the forearm to the barrel as seen in the figure. Make sure that the opening latch is completely closed.



6- Put the safety on by moving the safety switch to the rear

*Note : Disassemble by reversing the assembly instruction.*

## USAGE



1- Opening your shotgun by pushing the top lever to the right while pushing the barrel downward.



2- MAKE SURE THE SAFETY IS ON. (Moved to rear "S" exposed) Install the suitable cartridges according to your shotgun's gauge and chamber length.

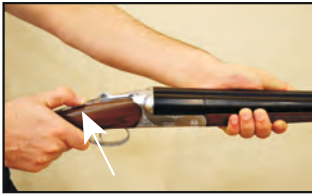

3- Barrel Selection (Single trigger models only) With safety on, move the selector located inside the safety to the left to fire the left barrel first. After firing the left barrel the right barrel will fire with another pull of the trigger.



4- Barrel Selection (Single trigger models only) With safety to the right to fire the right barrel first. After firing the right barrel the left barrel will fire with another pull of the trigger.



5- Barrel Selection (Single trigger models only) With safety on, move the selector located inside the safety to the right to fire

## CHOKE TUBES

The choke constriction is designated by a series of notches at the muzzle end of the choke tube.

**WARNING:** Never check the choke designation, install choke tubes or remove choke tubes unless the gun is unloaded and the action is open.



## DEFINITION AND THE USAGE OF CHOKE TUBES

Pattern With Lead Shot		Pattern With Steel Shot	Mark
★	Full	Not Recommended	
★★	Imp Mod	Not Recommended	
★★★	Mod	Full	
★ ★★★	Imp Cyl	Mod	
★★ ★★★	Cyl	Imp Cyl	

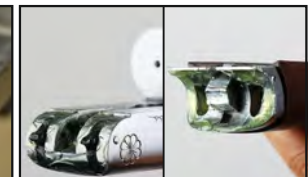

## Apply grease as shown

- ☒ Apply grease to all contact points between forend iron and receiver.
- ☒ Clean the barrel bore by passing a swab or cleaning patch through it to remove residue. If necessary, use a cleaning rod with a bore brush soaked in bore cleaning solvent.
- ☒ Run a clean dry cloth through the bore to remove excess residue
- ☒ Lightly oil the inside of the barrel with a clean patch coated with oil
- ☒ Apply a light coat of lubricant (preferably grease) to the connecting points of the receiver, barrels and forearm.
- ☒ Do not apply excess oil, grease or solvent. Excess cleaning fluids attract dirt, which can interfere with the function of the gun.
- ☒ Clean and lightly oil the external surface of the gun to remove any trace of dirt, moisture and fingerprints.

If you need further detailed maintenance contact a professional gunsmith.



## ASSEMBLY



1- Remove the magazine cap in front of the forearm by turning it counter-clockwise.



2- Attention: The action spring is located in the stock on 912 & 920 models, so spring will not be visible on the magazine tube.



3- (CZ 712 G2 & CZ 720 G2 Models Only) Unscrew the supporter nut off the front of the magazine tube



4- Slide the barrel lug over the magazine tube



5- While assembling the barrel pull back the bolt handle approximately one inch to the rear allowing for easier alignment of the barrel. Make sure the barrel seats completely into the receiver.



6- (CZ 712 G2 & CZ 720 G2 Models Only) Tighten the supporter nut on the magazine tube.



7- Assemble the forearm over the magazine tube and barrel. Make sure that the forearm is seated completely into the flange at the front of the receiver. Tighten the screw by turning clockwise.



8- Depress the button on the carrier, then when the bolt handle is pulled fully rearward the bolt will lock open.



9- Push the bolt release button on the right side of the receiver. Mechanism will slide strongly forward. **WARNING!** Be careful that your fingers are clear of the ejection port. Keep your hand below as seen in the figure.



10- Push the safety latch at the rear of the trigger guard fully to the right. Be sure that the RED color is not seen.

## LOADING



1- With the metal part of the shell at the rear, insert shells into the magazine tube until they lock. Repeat the operation until you have loaded the desired amount of shells. Make sure to load only suitable cartridges according to your shotgun's caliber & chamber specifications.



2- After filling the magazine push the cartridge drop lever (small latch at the back of carrier) to allow the cartridge to drop on the carrier. Pull the bolt handle back after releasing the first shell from the magazine tube and once the bolt is fully rearward, the bolt will go forward and chamber the round.



3- Pull the bolt handle back until the bolt locks in the rearward position. Push the bolt release button as seen in figure.



4- The bolt must be allowed to close forcefully to fully chamber the round. One cartridge from the magazine is now chambered. You can now place another cartridge into the magazine to replace the chambered round.

## FIRING

\* Push the safety to the left when you are ready to fire.  
\* You will see the RED color.  
\* Make sure your finger is not in contact with the trigger as you are taking the safety off.  
\* Now your shotgun is ready to fire.  
\* When you fire, your shotgun will automatically eject the fired cartridge and replace it with one from the magazine, until the gun is empty of ammunition.  
\* At this point, the bolt will remain locked open, indicating that all rounds have been fired.



Semi Auto Bolt Handle shown in proper alignment for removal. Note the spacing of the bolt handle in front of the curved handle slot.



Bolt handle the half way out position.

## UNLOADING



1- Pull the bolt handle to the rear to eject the round from the chamber



2- The bolt will return to the closed position.

3- Hold the carrier down and depress the feed latch.  
4- A cartridge will drop down to your finger on the carrier. Take out the cartridge. Repeat this operation until the magazine is empty. Depress the cartridge drop lever at the back of the carrier and pull the bolt handle rearward until the bolt locks open, demonstrating that the gun is completely unloaded.

## CHOKE TUBES

The choke constriction is designated by a series of notches at the muzzle end of the choke tube.

**WARNING:** Never check the choke designation, install choke tubes or remove choke tubes unless the gun is unloaded and the action is open.



## DEFINITION AND THE USAGE OF CHOKE TUBES

Pattern With Lead Shot		Pattern With Steel Shot	Mark
★	Full	Not Recommended	○
★★	Imp Mod	Not Recommended	○
★★★	Mod	Full	○
★ ★★★	Imp Cyl	Mod	○
★★★ ★★★	Cyl	Imp Cyl	○



## REMOVING MAGAZINE PLUG

\*The capacity of the shotgun is (4+1), but your shotgun is delivered to you as (2+1). You can change the capacity of the shotgun by removing the restrictor plug from the inside of the magazine tube.

\*(901 & 920 models) First remove the magazine cap. Gently pry the magazine cap upward and remove. Finish with re-install the magazine plug.



## MAINTENANCE



1- Unscrew the magazine cap.

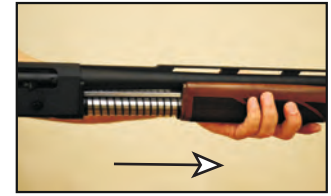

2- Remove the forearm by pushing it forward.



3- (CZ 712 G2 &amp; CZ 720 G2 Models Only) Unscrew the supporter nut off the front of the magazine tube.

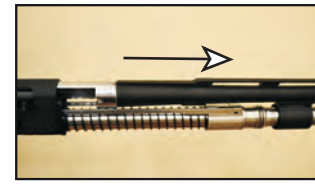

4- Dismantle the barrel by pulling forward and off the magazine tube.



5- O-ring is located inside the barrel ring so it's not visible on magazine tube.



6- Slide the gas piston off the front of the magazine tube



7- Push the latch under the trigger group (Loading figure 2/cartridge drop lever). Pull back the bolt handle. Clean the outer surface of magazine tube with a soft cloth.



8- Clean the inside and the outside of the piston using the same method.



9- Clean the gas ports on the inside of the barrel lug. Clean inside of the barrel lug.

- ☒ Clean the barrel bore by passing a swab or cleaning patch through it to remove residue. If necessary, use a cleaning rod with a bore brush soaked in bore cleaning solvent.
- ☒ Run a clean dry cloth through the bore to remove excess residue.
- ☒ Lightly oil the inside of the barrel with a clean patch coated with oil.
- ☒ Do not apply excess oil, grease or solvent. Excess cleaning fluids attract dirt, which can interfere with the function of the gun.
- ☒ Clean and lightly oil the external surface of the gun to remove any trace of dirt, moisture and fingerprints.
- ☒ Push the bolt release button while holding the bolt handle and allow the bolt to close slowly.
- ☒ Do not allow the bolt to close under force, since this may cause damage to the receiver. To assemble your shotgun reverse the disassembly instructions.

If you need further detailed maintenance contact a professional gunsmith.

TRIGGER ASSEMBLY REMOVAL



1. Firstly press the carrier button and put the Trigger Assembly on safe. Hit the punch, appropriate to be inserted in the hole, with a hammer to take out the Trigger Guard Pin (shown in the circle on the first picture) from other side of the receiver. THE EJECTION PORT SIDE OF THE RECEIVER MUST BE USED WHEN HITTING THE HAMMER AS SHOWN IN THE PICTURE.



3. Tap the trigger guard from back side in order to slide the Trigger Assembly forward and remove it.

TRIGGER ASSEMBLY MOUNTING



1. Keep the Trigger Assembly on safe and the carrier button pressed. Then put the Trigger Assembly into its place

2. Tap the Trigger Guard to slide the Trigger Assembly to the rear.



3. Install the Trigger Guard Pin after you make sure that the Trigger Assembly is fitted perfectly and the Trigger Assembly is aligned with the hole in the receiver. DO NOT USE THE EJECTION PORT SIDE OF THE RECEIVER WHEN YOU INSERT THE TRIGGER GUARD PIN INTO RECEIVER. INSERT THE PIN FROM OPPOSITE SIDE OF THE EJECTION PORT.

ASSEMBLY



1. Remove the magazine cap in front of the forearm by turning it counter-clockwise.

2. Remove the magazine cap in front of the forearm by turning it counter-clockwise.



3. Attach the Forearm to the Barrel by slotting the barrel lug into the Forearm.



4. Make sure that the Forearm seats into its place completely.



5. Before assembling the barrel, make sure that the Mechanism seats into its place completely and then pull the bolt handle back until the bolt locks open.

6. Slide the forearm over the magazine tube and the barrel into the receiver.

**⚠ Do not push the bolt release button when the barrel is off!**



7. Make sure the barrel seats completely into the receiver.

8. **POLYMER STOCK ASSEMBLY:** After the step 5, assemble the barrel into the receiver as shown.





9. **POLYMER STOCK ASSEMBLY:** Slide the forearm over the magazine tube



10. Tighten the magazine cap in front of the forearm by turning it clockwise.



11. Push the safety button at the front of the trigger guard fully to the right. Be sure that the RED color is not seen.

### LOADING 1



1. Insert shells into the magazine tube until they lock. Repeat the operation until you have loaded the desired amount of the shells. Make sure to load only suitable cartridges according to your shotgun's caliber & chamber specifications.



2. After filling the magazine push the cartridge drop lever (small latch at the back of carrier) to allow the cartridge to drop on the carrier.



3. Pull the bolt handle back after releasing the first shell from the magazine tube and once the bolt is fully rearward, the bolt will go forward and chamber the round.



4. The bolt must be allowed to close forcefully to fully chamber the round. One cartridge from the magazine is now chambered. You can now place another cartridge into the magazine to replace the chambered round.

### LOADING 2



1. Pull the bolt handle rearward until the bolt locks open.



2. Drop the first cartridge in the receiver.



3. Push the bolt release button and engage the safety.



4. Keep loading the magazine.

### UNLOADING



1. After filling the magazine push the cartridge drop lever to allow the cartridge to drop on the carrier.



2. Pull the bolt handle to the rear to eject the round from the chamber.



3. Push the carrier and depress on the back of the bolt release button. Cartridges will drop down to your finger on the carrier. Take out the cartridge. Repeat this operation until the magazine is empty. Depress the cartridge drop lever at the back of the carrier and pull the bolt handle rearward until the bolt locks open, demonstrating that the gun is completely unloaded.



**WARNING:** Never check the choke designation, install choke tubes or remove choke tubes unless the gun is unloaded and the action is open.

### REMOVING MAGAZINE PLUG

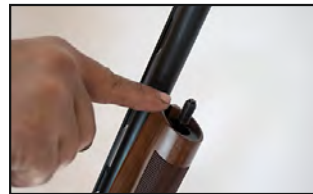

1. The capacity of the shotgun is (4+1), but your shotgun is delivered to you as (2+1). You can change the capacity of the shotgun by removing the restrictor plug from the inside of the magazine tube.



2. First remove the magazine cap. Cup upward and remove the plug. Re-install the magazine cap.

### FIRING

\* Push the safety to the left when you are ready to fire.

\* You will see the red color.

\* Make sure your finger is not in contact with the trigger as you are taking the safety off.

\* Now your shotgun is ready to fire.

\* When you fire, your shotgun will automatically eject the fired cartridge and replace it with one from the magazine, until the gun is empty of ammunition.

\* At this point, the bolt will remain locked open, indicating that all rounds have been fired.

STOCK ADJUSTMENT SHIM USAGE



1. Unscrew the butt pad screws by using a phillips screwdriver and take the butt pad out.



2. Unscrew the stock bolt using a socket wrench.



3. Remove the stock.



4. Take the stock supporter tube out.

To make the stock cast on (left handed) and upper, follow the instructions below:



5. Remove the "STANDART" marked shim from the action tube. (Your shotgun comes with "STANDART" shim that gives a no cast stock.)



6. Place the cast shim to the back of the receiver while the marking "L-R" is visible.



7. Place the drop shim with markings "U/ 1%" to the back of cast shim.



8. Drop and cast shims must fit when inserted.

**⚠ WARNING**

Even if you want no cast on the stock, cast plate "R" must be inserted into the stock.



9. Insert the cast plate (L) into the stock while the letter "L" is visible. (Your shotgun comes with "R" visible cast plate that gives no cast stock when used with "STANDART" drop shim.)



10. Place the stock over the action tube.



11. Put the stock supporter tube into the stock.



12. Screw the stock using a socket wrench.



13. Screw the butt pad screws by using a phillips screwdriver.

**DROP SHIMS**



STANDART DROP SHIM



U/1% DROP SHIM (UP)



U/2% DROP SHIM (UP)



D/1% DROP SHIM (DOWN)



D/2% DROP SHIM (DOWN)

**CAST PLATES**



FOR WOODEN STOCK  
(There is one plate with two-sided)



FOR POLYMER STOCK  
(There is one plate with two-sided)

**CAST SHIM**



If "L-R" is visible while placing, it is used for cast on (left handed)  
If there is no letter while placing, it is used for cast off (right handed)  
(There is one shim with two-sided)

CAST SHIMS/CAST PLATES (INCH)									
DROP SHIMS	RIGHT SHIM/RIGHT PLATE			LEFT SHIM/LEFT PLATE			NO CAST SHIM/RIGHT PLATE		
	COMB	HEEL	CAST OFF	COMB	HEEL	CAST ON	COMB	HEEL	CAST
STANDARD	1,535	2,441	0,157	1,535	2,441	0,157	1,535	2,441	0
U-%1	1,496	2,362	0,157	1,496	2,362	0,157	1,496	2,362	0
U-%2	1,417	2,165	0,157	1,417	2,165	0,157	1,417	2,165	0
D-%1	1,575	2,559	0,157	1,575	2,559	0,157	1,575	2,559	0
D-%2	1,614	2,717	0,157	1,614	2,717	0,157	1,614	2,717	0

**MAINTENANCE**

- \* Clean the barrel bore by passing a swab or cleaning patch through it to remove residue. If necessary, use a cleaning rod with a bore brush soaked in bore cleaning solvent.
- \* Run a clean dry cloth through the bore to remove excess residue.
- \* Lightly oil the inside of the barrel with clean patch coated with oil.
- \* Do not apply excess oil, grease or solvent. Excess cleaning fluids attract dirt, which can interfere with the function of the gun.
- \* Clean and lightly oil the external surface of the gun to remove any trace of dirt, moisture and fingerprints.  
\*Push the bolt release button while holding the bolt handle and allow the bolt to close slowly.  
Do not allow the bolt to close under force, since this may cause damage to the receiver.
- \* To assemble your shotgun, reverse the disassembly instructions.
- \* **If you need further detailed maintenance contact a professional gunsmith.**

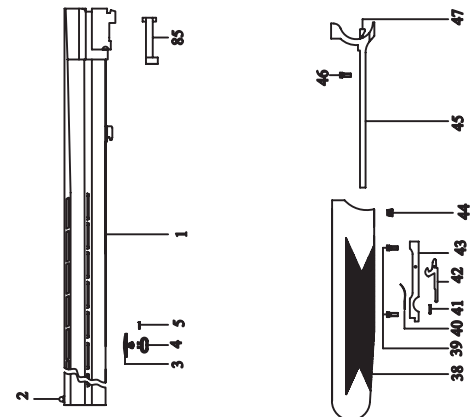
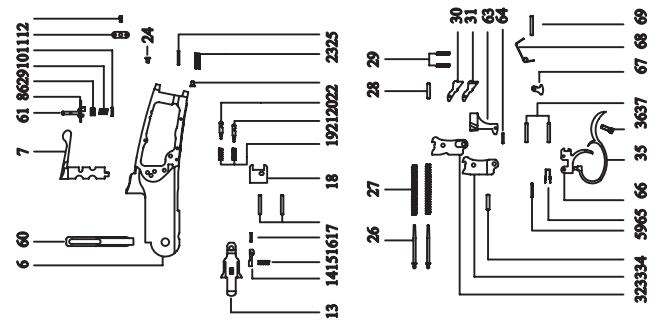
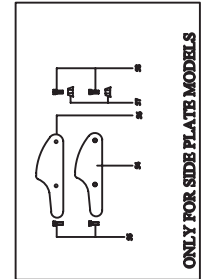
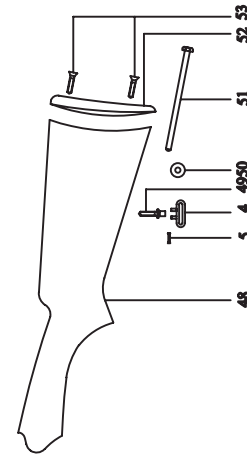



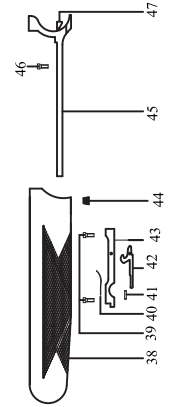
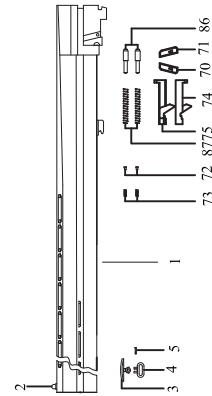
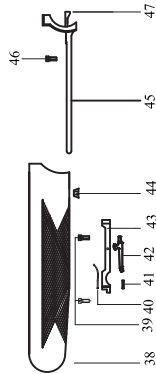
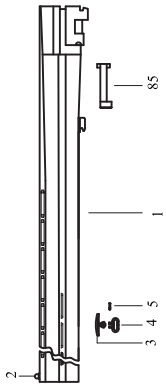
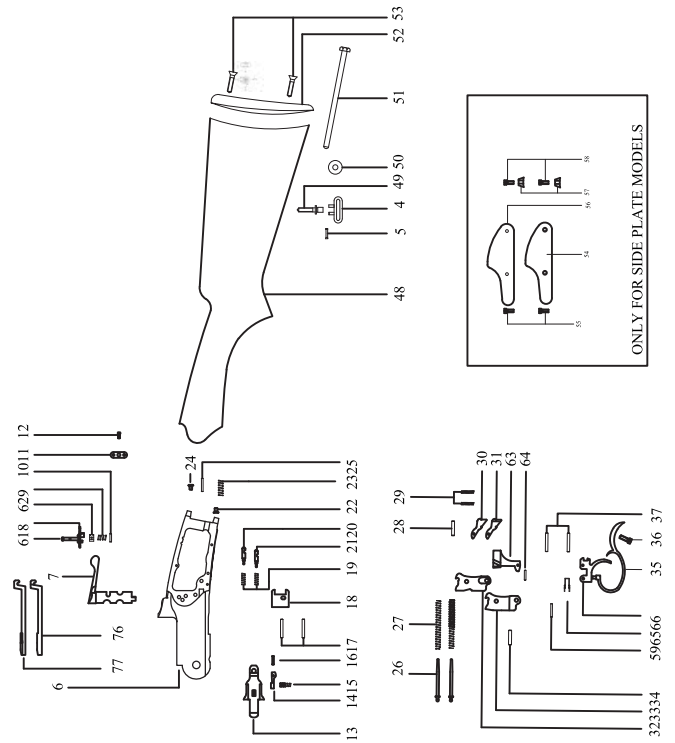
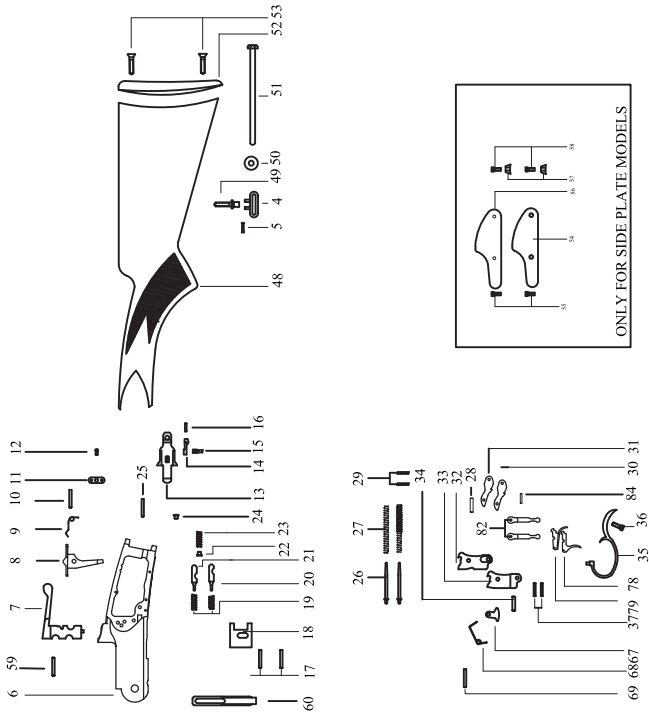

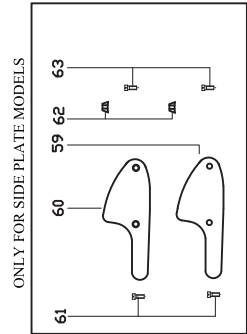
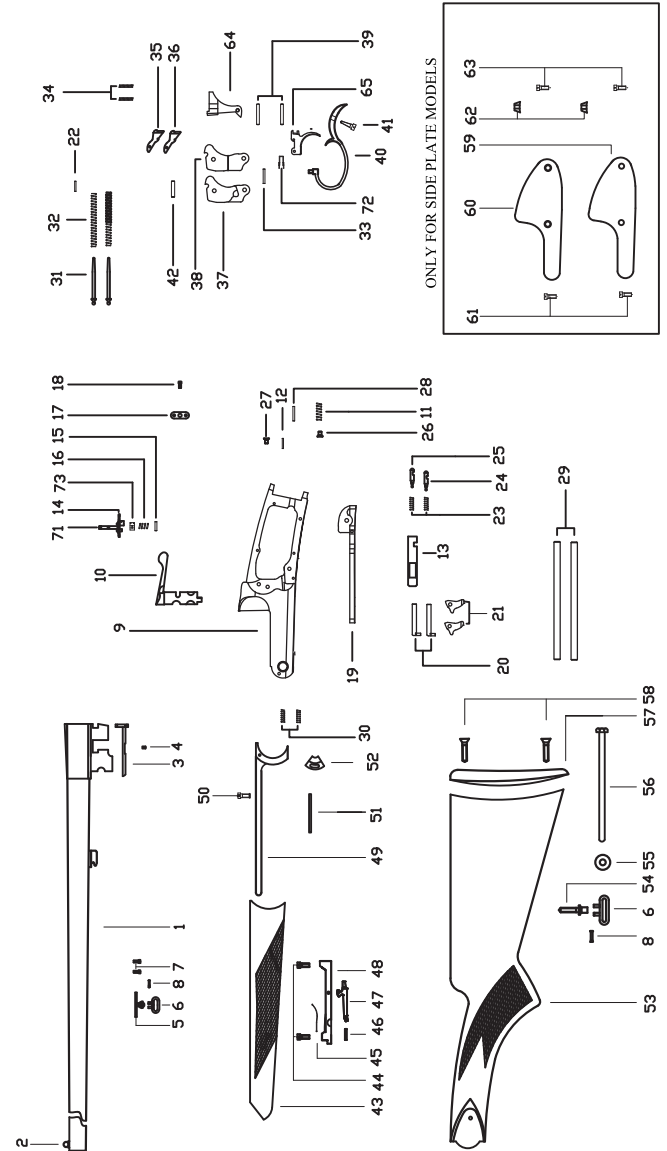
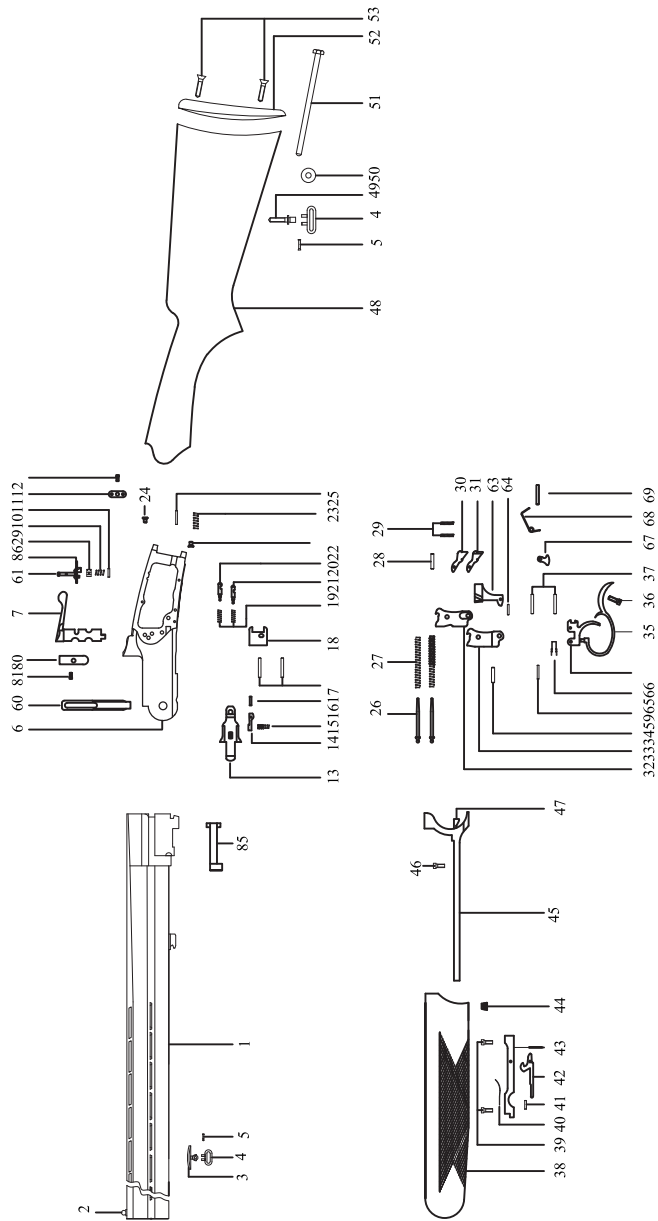

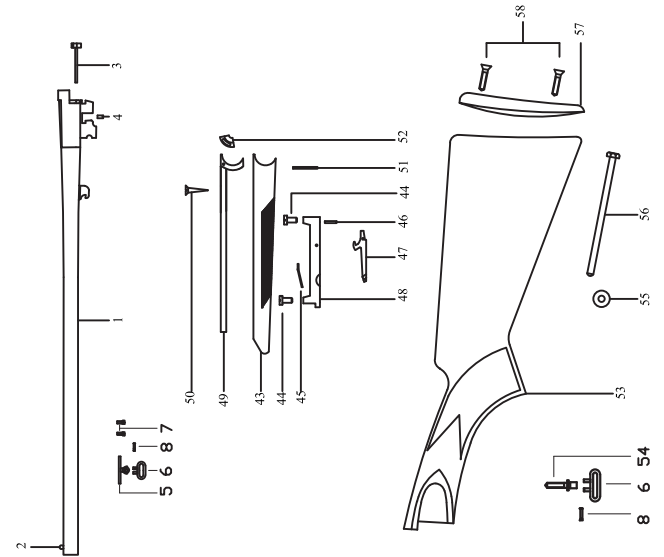
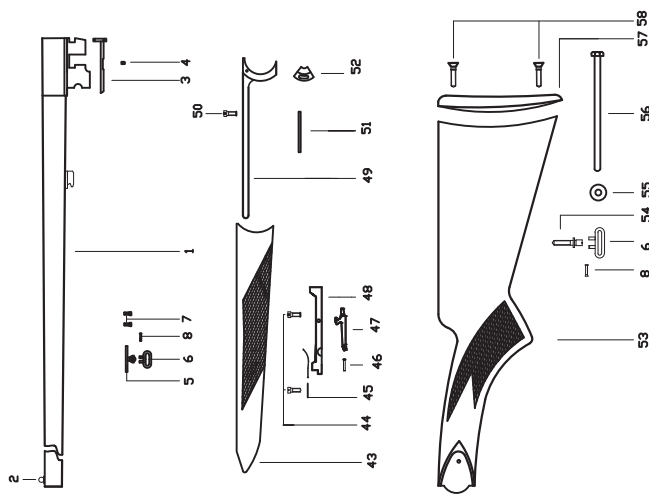
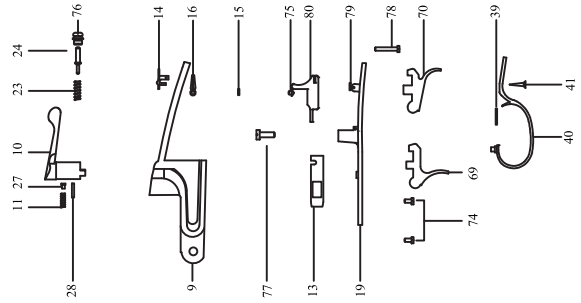
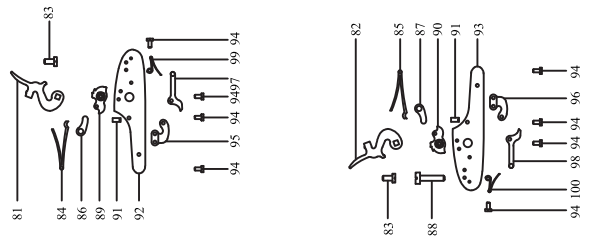
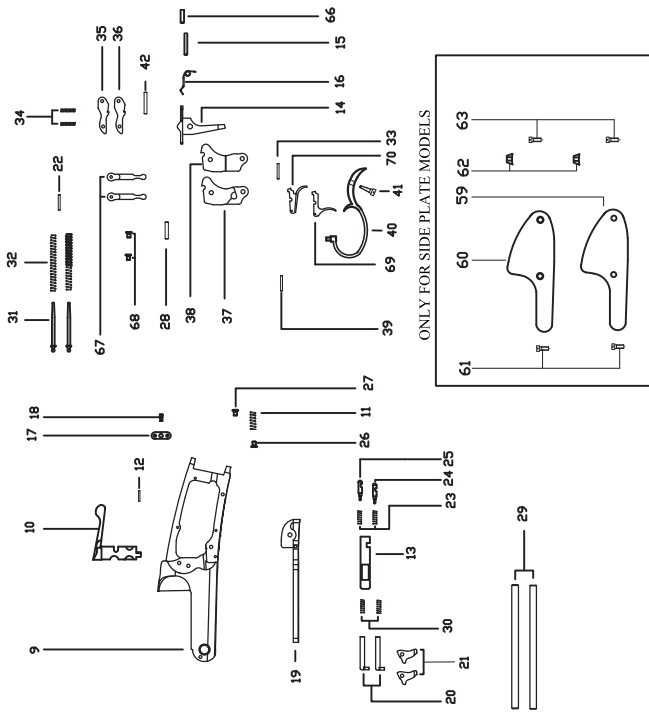

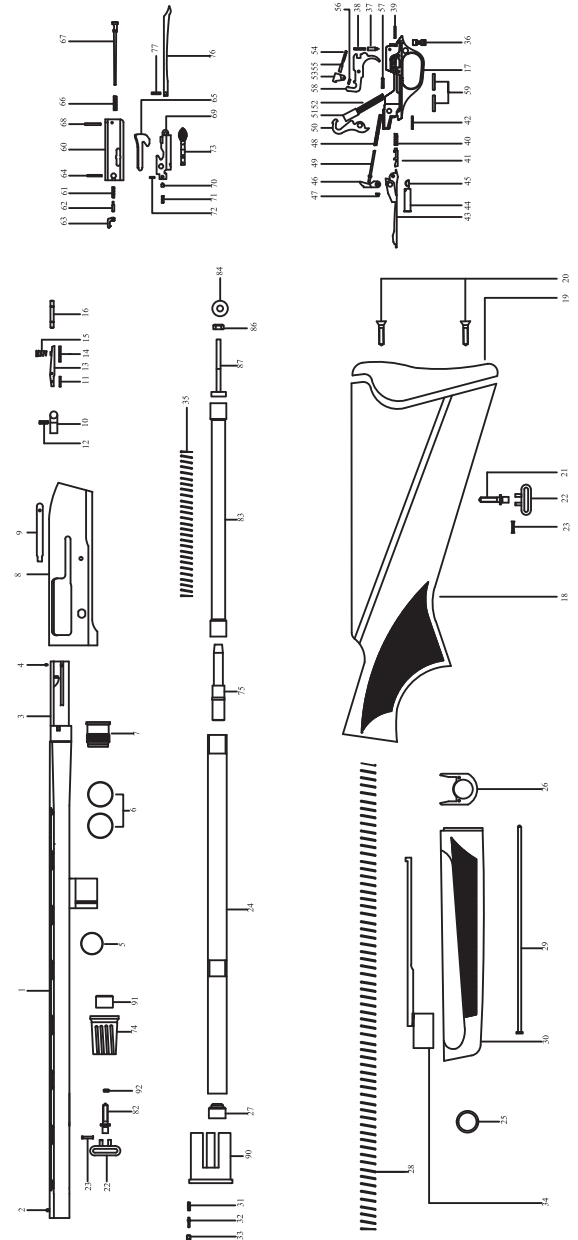
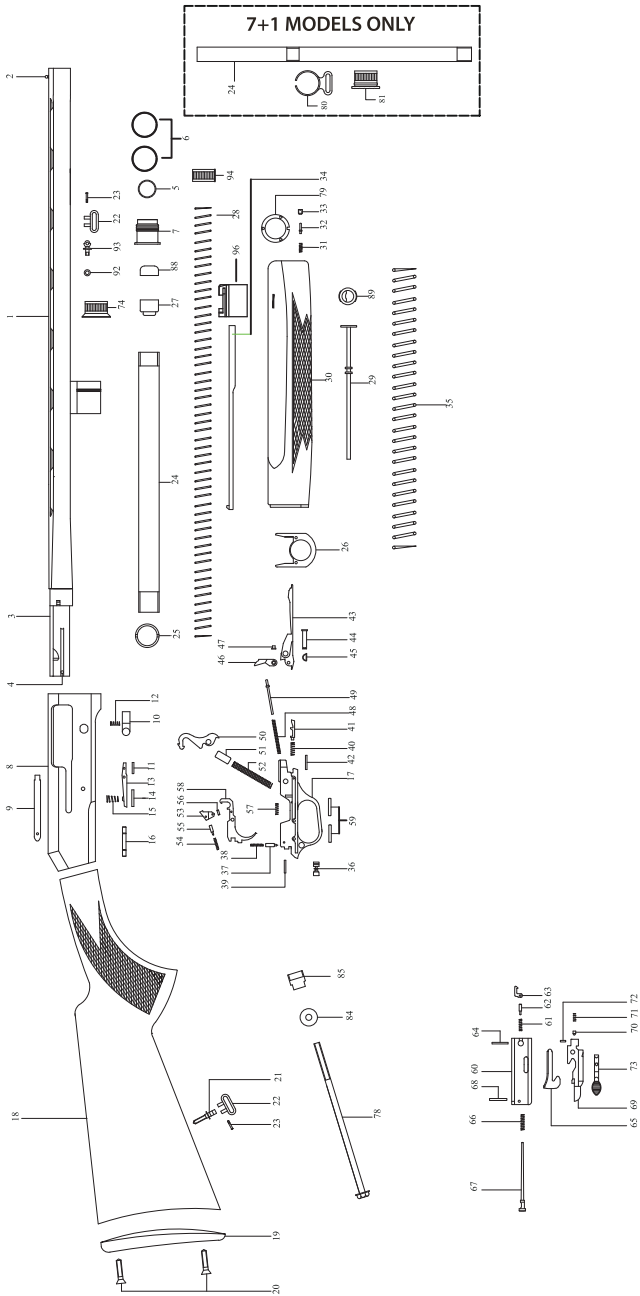



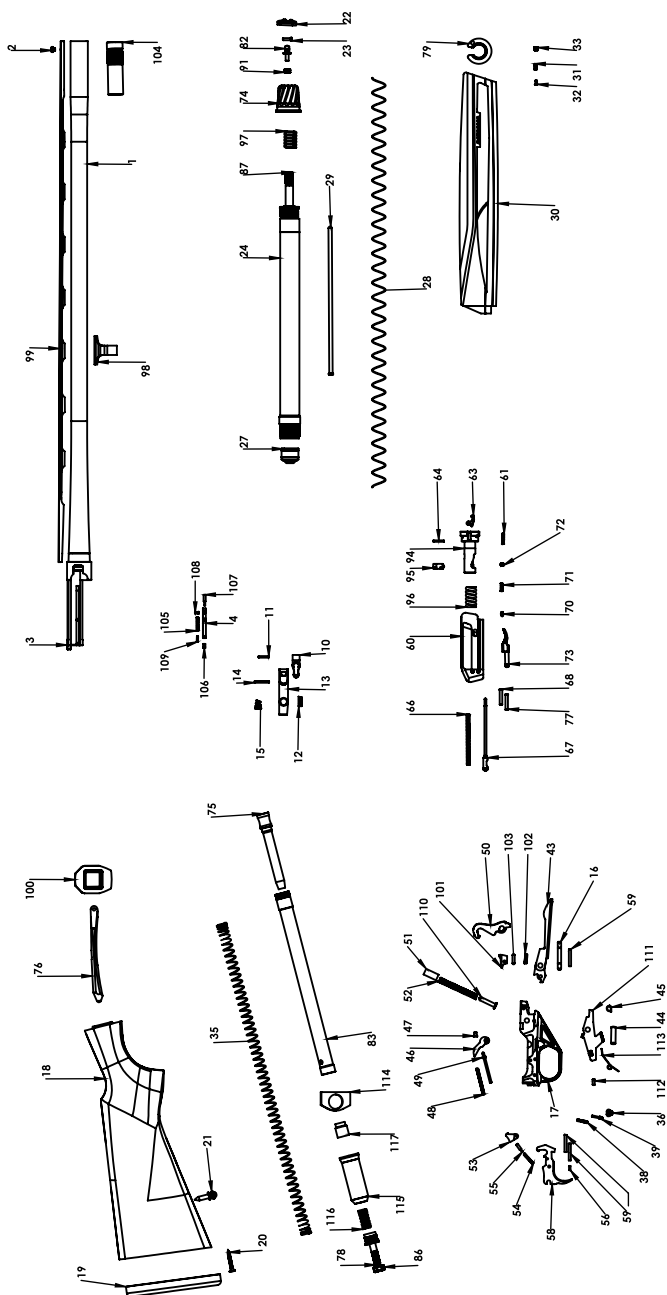

NO	PART NAME	NO	PART NAME
1	BARREL	59	TRIGGER PIN
2	FRONT BEAD	60	BREECH BOLT
3	BEARING BOLT	61	EXTRACTOR SPRING
4	EJECTOR	62	EXTRACTOR SPRING PIN
5	RUBBER GAS RING	63	EXTRACTOR
6	GAS PISTON WASHER	64	EXTRACTOR RETAINING PIN
7	GAS PISTON	65	LOCKING BLOCK
8	RECEIVER	66	FIRING PIN SPRING
9	TRACER WEDGE	67	FIRING PIN
10	BOLT RELEASE	68	FIRING PIN RETAINER
11	BOLT RELEASE PIN	69	BOLT BLOCK
12	BOLT RELEASE SPRING	70	BOLT LEVER BLOCK PIN
13	BOLT RELEASE LATCH	71	BOLT LEVER BLOCK SPRING
14	BOLT RELEASE LATCH PIN	72	BOLT LEVER BLOCK SPRING PIN
15	BOLT RELEASE LATCH SPRING	73	OPERATING HANDLE
16	TRIGGER GUARD PIN	74	MAGAZINE CAP
17	TRIGGER GUARD	75	ACTION PIPE
18	STOCK	76	ACTION SUPPORTER
19	BUTT PLATE	77	ACTION SUPPORTER PIN
20	BUTT PLATE SCREW	78	STOCK BOLT
21	STOCK SWIVEL STUD	79	MAGAZINE CAP SUPPORT
22	SWIVEL	80	7+1 SWIVEL
23	SWIVEL PIN	81	7+1 MAGAZINE CAP
24	MAGAZINE TUBE	82	MAGAZINE CAP SWIVEL HOLDER
25	FOREARM SUPPORT RING	83	ACTION TUBE
26	FOREARM PLATE RING	84	STOCK BOLT WASHER
27	MAGAZINE FOLLOWER	85	STOCK BOLT RECEIVER
28	MAGAZINE SPRING	86	STOCK BOLT RING
29	MAGAZINE PLUG	87	MAGAZINE SPRING RETAINER
30	FOREARM	88	MAGAZINE PLUG RETAINER
31	MAGAZINE CAP SPRING	89	PLUG PLATE
32	MAGAZINE CAP PIN	90	MAGAZINE CAP INTERIOR
33	MAGAZINE CAP SCREW	91	SWIVEL STUD RETAINER
34	ACTION BAR	92	SUPPORTER NUT
35	ACTION SPRING	93	ACTION BAR SLEEVE
36	SAFETY	94	LOCKING HEAD
37	SAFETY PLUNGER	95	LOCKING HEAD PIN
38	SAFETY SPRING	96	LOCKING HEAD SPRING
39	SAFETY SPRING PLUNGER	97	MAGAZINE CAP SPRING
40	CARRIER SPRING	98	BARREL LUG
41	CARRIER PLUNGER	99	TOP RIB
42	CARRIER RETAINING PIN	100	STOCK ADJUSTMENT SHIM
43	CARRIER	101	HAMMER SAFETY
44	TRIGGER ASSEMBLY PIN SLEEVE	102	HAMMER SAFETY SPRING
45	TRIGGER ASSEMBLY PIN RETAINER	103	HAMMER SAFETY PIN
46	CARRIER DOG	104	MOBILE CHOKE
47	CARRIER DOG PIN	105	EJECTOR SPRING
48	CARRIER DOG SPRING	106	EJECTOR SPRING PIN
49	CARRIER DOG PLUNGER	107	EJECTOR PIN
50	HAMMER	108	EJECTOR RETAINING PIN 1
51	HAMMER PLUNGER	109	EJECTOR RETAINING PIN 2
52	HAMMER SPRING	110	HAMMER SPRING PIN
53	SEAR	111	CARTRIDGE DROP LEVER
54	SEAR SPRING	112	CARTRIDGE DROP LEVER SPRING PIN
55	SEAR PLUNGER	113	CARTRIDGE DROP LEVER SPRING
56	SEAR PIN	114	STOCK ADJUSTMENT PLATE
57	TRIGGER SPRING	115	STOCK SUPPORTER TUBE
58	TRIGGER	116	DAMPER SPRING
		117	DAMPER SPRING PLUG

## OVER &amp; UNDER PART LIST

P.No.	PART NAME	P.No.	PART NAME
1	BARREL	45	FOREARM IRON
2	FRONT BEAD	46	ESCUTCHEON SCREW
3	BARREL SWIVEL STUD	47	FOREARM COCKING ARM
4	SWIVEL	48	STOCK
5	SWIVEL SCREW	49	STOCK SWIVEL STUD
6	RECEIVER	50	STOCK BOLT WASHER
7	TOP LEVER	51	STOCK BOLT
8	SAFETY	52	BUTT PLATE
9	SAFETY SPRING	53	BUTT PLATE SCREW
10	SAFETY SPRING PIN	54	SIDE PLATE (LEFT)
11	HAMMER SPRING PLATE	55	SIDE PLATE SCREW
12	HAMMER SPRING PLATE SCREW	56	SIDE PLATE (RIGHT)
13	LOWER RECEIVER	57	SIDE PLATE ESCUTCHEON COVER SCREW
14	LOCKING BLOCK HOLDER	58	SIDE PLATE COVER SCREW
15	LOCKING BLOCK HOLDER SPRING	59	TOP LEVER PIN
16	LOCKING BLOCK HOLDER PIN	60	COCKING ARM
17	FIRING PIN PINTLE	61	SAFETY LEVER
18	LOCKING BLOCK	62	SAFETY WASHER
19	FIRING PIN SPRING	63	SELECTOR
20	FIRING PIN (TOP)	64	SELECTOR PIN
21	FIRING PIN (BOTTOM)	65	TRIGGER SPRING
22	TOP LEVER SPRING PIN	66	TRIGGER
23	TOP LEVER SPRING	67	ROLLER
24	TOP LEVER SPRING RETAINER	68	ROLLER SPRING
25	TOP LEVER SPRING RETAINING PIN	69	ROLLER PIN
26	HAMMER SPRING PIN	70	WEDGE (RIGHT)
27	HOROZ YAYI / HAMMER SPRING	71	WEDGE (LEFT)
28	SEAR PIN	72	EJECTOR SEAR PIN
29	SEAR SPRING	73	EJECTOR SEAR SPRING
30	SEAR (RIGHT)	74	EJECTOR (RIGHT)
31	SEAR (LEFT)	75	EJECTOR (LEFT)
32	HAMMER (RIGHT)	76	COCKING ARM (RIGHT)
33	HAMMER (LEFT)	77	COCKING ARM (LEFT)
34	HAMMER PIN	78	TRIGGER (RIGHT)
35	TRIGGER GUARD	79	TRIGGER (LEFT)
36	TRIGGER GUARD SCREW	80	DAGGER
37	TRIGGER PIN	81	DAGGER SCREW
38	FOREARM	82	SEAR LEVER
39	TAKE DOWN LATCH SCREW	83	SAFETY PIN
40	TAKE DOWN LATCH SPRING	84	SEAR LEVER PIN
41	TAKE DOWN LATCH PIN	85	EXTRACTOR
42	TAKE DOWN LATCH	86	EJECTOR SPRING PIN
43	TAKE DOWN LATCH BRACKET	87	EJECTOR SPRING
44	ESCUTCHEON COVER SCREW		

## SIDE BY SIDE PART LIST

P.No.	PART NAME	P.No.	PART NAME
1	BARREL	50	FOREARM COCKING ARM PIN
2	FRONT BEAD	51	FOREARM COCKING ARM
3	EXTRACTOR	52	STOCK
4	EXTRACTOR SCREW	53	STOCK SWIVEL STUD
5	BARREL SWIVEL STUD	54	STOCK BOLT WASHER
6	SWIVEL	55	STOCK BOLT
7	BARREL SWIVEL STUD SCREW	56	BUTT PLATE
8	SWIVEL SCREW	57	BUTT PLATE SCREW
9	RECEIVER	58	SIDE PLATE (LEFT)
10	TOP LEVER	59	SIDE PLATE (RIGHT)
11	TOP LEVER SPRING	60	SIDE PLATE SCREW
12	TOP LEVER SPRING RETAINING PIN	61	SIDE PLATE ESCUTCHEON COVER SCREW
13	LOCKING BLOCK	62	SIDE PLATE COVER SCREW
14	SAFETY	63	SELECTOR
15	SAFETY SPRING PIN	64	TRIGGER
16	SAFETY SPRING	65	SAFETY PIN
17	HAMMER SPRING PLATE	66	SEAR LEVER
18	HAMMER SPRING PLATE SCREW	67	SEAR LEVER PIN
19	LOWER RECEIVER	68	TRIGGER (RIGHT)
20	COCKING ARM CARRIERS	69	TRIGGER (LEFT)
21	COCKING ARM LEVER	70	SAFETY LEVER
22	FIRING PIN PINTLE	71	TRIGGER SPRING
23	FIRING PIN SPRING	72	SAFETY WASHER
24	FIRING PIN (LEFT)	73	LOWER RECEIVER PIN
25	FIRING PIN (RIGHT)	74	SAFETY SPRING PIN
26	TOP LEVER SPRING PLUNGER	75	CROWN
27	TOP LEVER SPRING RETAINER	76	TANG SCREW
28	TOP LEVER LOCKING PIN	77	LOWER RECEIVER REAR SCREW
29	COCKING ARM	78	SAFETY INTERIOR PIN
30	COCKING ARM SPRING	79	SAFETY INTERIOR
31	HAMMER SPRING PIN	80	HAMMER (LEFT)
32	HAMMER SPRING	81	HAMMER (RIGHT)
33	HAMMER PIN	82	HAMMER SCREW
34	SEAR-SELECTOR SPRING	83	HAMMER SPRING (LEFT)
35	SEAR (RIGHT)	84	HAMMER SPRING (RIGHT)
36	SEAR (LEFT)	85	HOLDER (LEFT)
37	HAMMER (LEFT)	86	HOLDER (RIGHT)
38	HAMMER (RIGHT)	87	PLATE IMMOBILIZATION SCREW
39	TRIGGER PIN	88	PUMP (LEFT)
40	TRIGGER GUARD	89	PUMP (RIGHT)
41	TRIGGER GUARD SCREW	90	HAMMER SPRING CONTRA SCREW
42	SEAR PIN	91	SIDE LOCK (LEFT)
43	FOREARM	92	SIDE LOCK (RIGHT)
44	TAKE DOWN LATCH SCREW	93	RESTRAINT SEAR SCREW
45	TAKE DOWN LATCH SPRING	94	RESTRAINT (LEFT)
46	TAKE DOWN LATCH PIN	95	RESTRAINT (RIGHT)
47	TAKE DOWN LATCH	96	SEAR (LEFT)
48	TAKE DOWN LATCH BRACKET	97	SEAR (RIGHT)
49	FOREARM IRON	98	SEAR-SELECTOR SPRING (LEFT)
50	ESCUTCHEON SCREW	99	SEAR-SELECTOR SPRING (RIGHT)
		100	