

SEMIAUTO

SHOTGUN  
USER MANUAL



## Table of contents

Warning, Caution and Notice .....	1
Basic safety rules .....	4
Technical features .....	9
Nomenclature .....	12
Assembly .....	16
Load check .....	23
Use .....	25
Field stripping .....	33
Routine maintenance .....	37
Reassembly .....	39
Accessories and settings .....	43
Choke tubes .....	43
Stock drop and cast modification .....	49
B-Lock cap .....	62
B-Fast rib .....	64
Storage .....	67
Warranty .....	67

---

Warning, Caution and Notice are defined as follows:

 **WARNING**

**THE PURPOSE OF A WARNING IS TO DRAW ATTENTION TO A POTENTIALLY DANGEROUS SITUATION THAT COULD RESULT IN PERSONAL INJURY.**

 **CAUTION**

A CAUTION concerns potential damage to the shotgun.

 **Notice**

A NOTICE highlights important procedures and statements that require more emphasis than general text.

The references “left” or “right” always refer to the shotgun as shouldered by the user.  
**The contents of this manual are subject to change without notice.**

 **WARNING**

THIS MANUAL CONTAINS IMPORTANT WARNINGS THAT MUST BE UNDERSTOOD BEFORE USING THIS SHOTGUN.

PLEASE RETAIN THIS COPY OF THE INSTRUCTION MANUAL FOR FUTURE REFERENCE. ANY TRANSFER OF THIS SHOTGUN SHOULD INCLUDE A COPY OF THIS MANUAL. IF YOU LEND, GIVE OR SELL THE SHOTGUN TO ANYONE, BE SURE THE INSTRUCTION MANUAL ACCOMPANIES IT AS A SAFETY AND OPERATIONAL REFERENCE.

 **WARNING**

FIREARMS CAN BE DANGEROUS AND CAN POTENTIALLY CAUSE SERIOUS INJURY, DAMAGE TO PROPERTY OR DEATH, IF HANDLED IMPROPERLY. THE FOLLOWING SAFETY RULES ARE AN IMPORTANT REMINDER THAT SHOTGUN SAFETY IS YOUR RESPONSIBILITY.

 **WARNING**

ALWAYS ENSURE THAT THE SAFETY IS FULL ENGAGED UNTIL READY TO FIRE. CAREFULLY READ THE “SAFETY” PARAGRAPH IN THIS MANUAL BEFORE USING THIS SHOTGUN.

 **WARNING**

READ THE ENTIRE MANUAL CAREFULLY BEFORE USING THIS SHOTGUN. MAKE SURE THAT ANY PERSON USING OR HAVING ACCESS TO THIS SHOTGUN READS AND UNDERSTANDS ALL OF THIS MANUAL PRIOR TO USE OR ACCESS.

WE RECOMMEND THE USE OF ORIGINAL BERETTA SPARE PARTS AND ACCESSORIES. THE USE OF OTHER MANUFACTURER’S SPARE PARTS AND ACCESSORIES COULD CAUSE MALFUNCTIONS AND/OR BREAKAGES THAT WILL NOT BE COVERED BY THE BERETTA WARRANTY.

 **Notice**

The Manufacturer and/or its Local Official Distributors assume no responsibility for product malfunction, or for physical injury or property damage resulting wholly or partially from criminal or negligent use of the product, improper or careless handling, unauthorized modifications, use of defective, improper, handloaded, reloaded or remanufactured ammunition, customer abuse or neglect of the product, or other influences beyond manufacturer's direct and immediate control.

In addition to the Basic Safety Rules, there are other Safety Rules pertaining to the loading, unloading, disassembly, assembly and use of this shotgun, located throughout this manual.

## BASIC SAFETY RULES

### 1. NEVER POINT A FIREARM AT SOMETHING THAT IS NOT SAFE TO SHOOT.

Never let the muzzle of a firearm point at any part of your body or at another person. This is especially important when loading or unloading the firearm. When you are shooting at a target, know what is behind it. Some bullets can travel over a mile. If you miss your target or if the bullet penetrates the target, it is your responsibility to ensure that the shot does not cause unintended injury or damage.



### 2. ALWAYS TREAT A FIREARM AS IF IT WERE LOADED.

Never assume that a firearm is unloaded. The only certain way to ensure there are no cartridges in a firearm is to open the chamber and visually and physically examine the inside to see if a round is present. Removing or unloading the magazine will not guarantee that a firearm is unloaded or cannot fire. Firearms and rifles can be checked by cycling or removing all rounds and by then opening and inspecting the chamber so that a visual inspection of the chamber for any remaining rounds can be made.

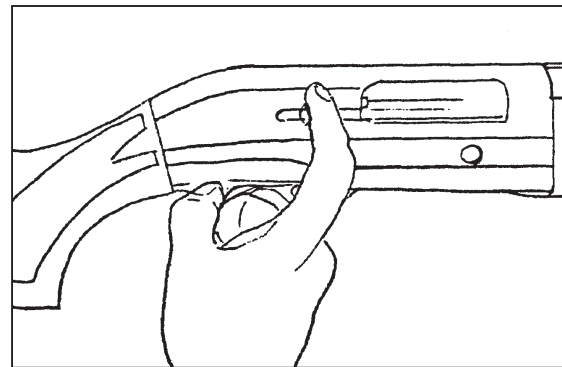
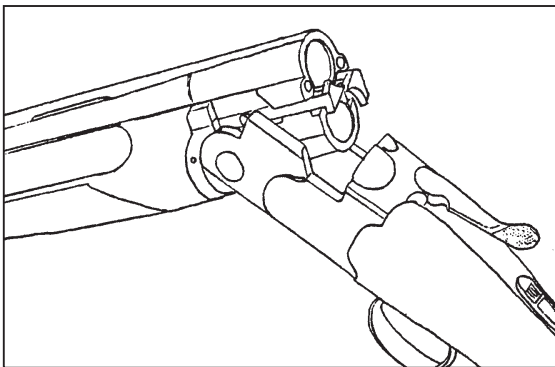
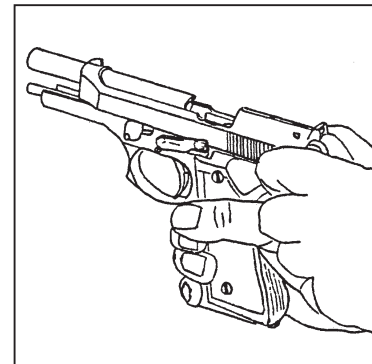

### 3. STORE YOUR FIREARM SO THAT CHILDREN CANNOT GAIN ACCESS TO IT.

It is your responsibility to ensure that children under the age of 18 or other unauthorised persons do not gain access to your firearm. To reduce the risk of accidents involving children, unload your firearm, lock it and store the ammunition in a separate locked location. Please note that devices intended to prevent accidents - for example, cable locks, chamber plugs, etc., - may not prevent use or misuse of your firearm by a determined person. Firearm storage in a steel gun safe may be more appropriate to reduce the likelihood of intentional misuse of a firearm by a child or unauthorised person.

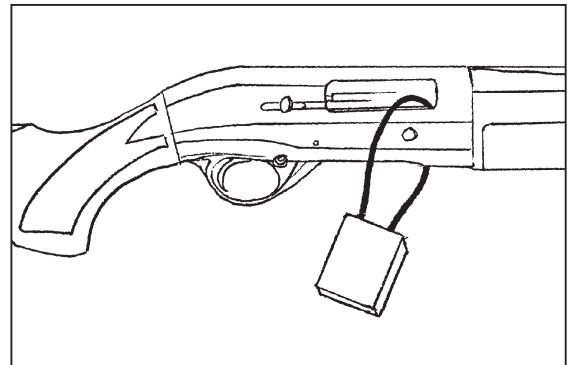
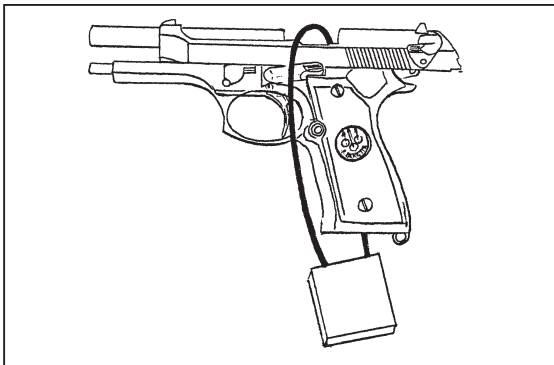

### 4. NEVER SHOOT AT WATER OR AT A HARD SURFACE.

Shooting at the surface of water or at a rock or other hard surface increases the chance of ricochets or fragmentation of the bullet or shot, which can result in the projectile striking an unintended or peripheral target.



### 5. KNOW THE SAFETY FEATURES OF THE FIREARM YOU ARE USING, BUT REMEMBER: SAFETY DEVICES ARE NOT A SUBSTITUTE FOR SAFE HANDLING PROCEDURES.

Never rely solely on a safety device to prevent an accident. It is imperative that you know and use the safety features of the particular firearm you are handling, but accidents can best be prevented by following the safe handling procedures described in these safety rules and elsewhere in the product manual. To further familiarise yourself with the proper use of this or other firearms, take a Firearms Safety Course taught by an expert in firearms use and safety procedures.

## 6. PROPERLY MAINTAIN YOUR FIREARM.

Store and carry your firearm so that dirt or lint does not accumulate in the working parts. Clean and oil your firearm, following the instructions provided in this manual, after each use to prevent corrosion, damage to the barrel or accumulation of impurities which can prevent use of the firearm in an emergency. Always check the bore and chamber(s) prior to loading to ensure that they are clean and free from obstructions. Firing with an obstruction in the barrel or chamber can rupture the barrel and injure you or others nearby. In the event you hear an unusual noise when shooting, stop firing immediately, engage the manual safety and unload the firearm. Make sure the chamber and barrel are free from any obstruction, like a bullet blocked inside the barrel due to defective or improper ammunition.

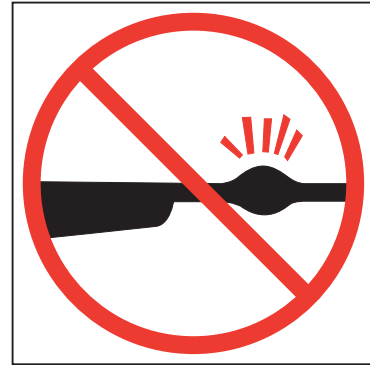

## 7. USE PROPER AMMUNITION.

Only use factory-loaded, new ammunition manufactured to industry specifications: CIP (Europe and elsewhere), SAAMI® (U.S.A.). Be certain that each round you use is in the proper calibre or gauge and type for the particular firearm. The calibre or gauge of the firearm is clearly marked on the barrels of firearms and on the slide or barrel of pistols. The use of reloaded or remanufactured ammunition can increase the likelihood of excessive cartridge pressures, case-head ruptures or other defects in the ammunition that can cause damage to your firearm and injury to yourself or others nearby.

## 8. ALWAYS WEAR PROTECTIVE EYEWEAR AND EARPLUGS WHEN SHOOTING.

The chance that gas, gunpowder or metal fragments will blow back and injure a shooter who is firing a gun is rare, but the injury that can be sustained in such circumstances can be severe, including the possible loss of eyesight. A shooter must always wear impact resistant shooting glasses when firing any firearm. Noise-reducing earplugs or headphones will reduce the risk of damage to hearing caused by prolonged shooting activity.





### 9. NEVER CLIMB A TREE, FENCE OR OBSTRUCTION WITH A LOADED SHOTGUN.

Open and empty the chamber(s) of your firearm and engage the manual safety before climbing or descending a tree or before climbing a fence or jumping over a ditch or other obstruction. Never pull or push a loaded firearm toward yourself or another person. Always unload a firearm, visually and physically check to see that the magazine, loading mechanism and chamber are unloaded, the action is open before handing it to another person. Never take a firearm from another person unless it is unloaded, visually and physically checked to confirm it is unloaded, and the action is open.



### 10. AVOID ALCOHOLIC BEVERAGES OR JUDGMENT/REFLEX IMPAIRING MEDICATION WHEN SHOOTING.

Do not drink and shoot. If you take medication that can impair motor reactions or judgement, do not handle a firearm while you are under the influence of the medication.



### 11. NEVER TRANSPORT A LOADED FIREARM.

Unload a firearm before putting it in a vehicle (chamber empty, magazine empty). Hunters and target shooters should load their firearm only at their destination, and only when they are ready to shoot. If you carry a firearm for self-protection, leaving the chamber unloaded can reduce the chance of an unintentional discharge.



## 12. LEAD WARNING.

Discharging firearms in poorly ventilated areas, cleaning firearms, or handling ammunition may result in exposure to lead and other substances known to cause birth defects, reproductive harm, and other serious physical injury. Have adequate ventilation at all times. Wash hands thoroughly after exposure.

### **Notice**

It is YOUR responsibility to know and abide by Federal, State and Local laws governing the sale, transportation and use of firearms in your area.

### **WARNING**

**THIS FIREARM HAS THE CAPABILITY TO TAKE YOUR LIFE OR THE LIFE OF SOMEONE ELSE!**

**ALWAYS BE EXTREMELY CAREFUL WITH YOUR FIREARM.**

**AN ACCIDENT IS ALMOST ALWAYS THE RESULT OF NOT FOLLOWING BASIC FIREARM SAFETY RULES.**

**BEFORE USING THE FIREARM OR CARRYING OUT ANY OPERATION IN THIS MANUAL, BE SURE TO FOLLOW THE BASIC SAFETY RULES CAREFULLY.**

### **WARNING**

**BERETTA ACCEPTS NO RESPONSIBILITY FOR INJURY OR PROPERTY DAMAGE CAUSED BY IMPROPER OR CARELESS HANDLING OF THE FIREARM OR BY INTENTIONAL OR CARELESS DISCHARGE OF THE FIREARM.**

Model	Features					Stock				Other			Barrels available										Chokes	
	Gauge	Cartridge chamber	With gas valve	Cross tube magazine	Colour/finish receiver case	Base	KICK-OFF	KICK-OFF PLUS	KICK-OFF M (Mega)	KICK-OFF PLUS (Wood)	B-LOK	GUNPOD	Ready for GUNPOD	SLUG (22")	SLUG (24")	47 cm (18.5")	53 cm (21")	61 cm (24")	66 cm (26")	71 cm (28")	76 cm (30")	81 cm (32")		86 cm (34")
Xplor Action	12	3"	•		A	•	•				•	•	•	•				•	•	•	•			OCHP
Xplor Action	20	3"			A	•	•					•						•	•	•	•			OCHP
Xplor Action	28	2 <sup>3</sup> / <sub>4</sub> "			A	•																		OCHP
Ultralite	12	3"	•		B	•	•					•						•	•	•	•			OCHP
Upland	12	3"	•		C	•					•							•	•	•	•			OCHP
Xtreme Plus	12	3 <sup>1</sup> / <sub>2</sub> "	•	•	D		•	•																OCHP
Xtreme Plus Left Handed	12	3 <sup>1</sup> / <sub>2</sub> "	•	•	D		•	•																OCHP
Lite	12	3"	•	•	E							•												OCHP

Key:

**A:** anodized bronze  
**E:** anodized black or Camo

**B:** anodized black  
**F:** anodized blue

**C:** nickel plated  
**G:** anodized black or Cerakote®

**D:** Cerakote® and/or Camo

Model	Features					Stock				Other			Barrels available										Chokes		
	Gauge	Chamber	With gas valve	Cross tube magazine	Colour/finish receiver case	Base	KICK-OFF	KICK-OFF PLUS	KICK-OFF M (Mega)	KICK-OFF PLUS (Wood)	B-LOK	GUNPOD	Ready for GUNPOD	SLUG 56 cm (22")	SLUG 61 cm (24")	47 cm (18.5")	53 cm (21")	61 cm (24")	66 cm (26")	71 cm (28")	76 cm (30")	81 cm (32")		86 cm (34")	
A400	12	3"	•	•	E		•					•							•	•	•				Suitable type
Lite Left Handed	20	3"		•	E		•					•							•	•	•				OCHP
Lite	20	3"		•	B	•						•						•	•	•	•				OCHP
Lite Compact	20	3"		•	F	•						•						•	•	•	•				OCHP
Xcell Sporting/Black Edition	12	3"	•		F	•						•													OCHP
Xcell Sporting	20	3"			F	•						•													OCHP
Xcell Parallel Target	12	3"	•		F							•								•	•	•			OCHP
Xcell Multitarget	12	3"	•		C	•														•	•	•			OCHP

Key:

- A:** anodized bronze
- B:** anodized black
- C:** nickel plated
- D:** Cerakote® and/or Camo
- E:** anodized black or Camo
- F:** anodized blue
- G:** anodized black or Cerakote®

	Features					Stock				Other			Barrels available										Chokes		
	Gauge	Chamber cartridge	With gas valve	Cross tube magazine	Colour/finish receiver case	Base	KICK-OFF	KICK-OFF PLUS	KICK-OFF M (Mega)	KICK-OFF PLUS (Wood)	B-LOK	GUNPOD	Ready for GUNPOD	SLUG (22")	SLUG (24")	47 cm (18.5")	53 cm (21")	61 cm (24")	66 cm (26")	71 cm (28")	76 cm (30")	81 cm (32")	86 cm (34")	Suitable type	
<b>Model A350</b>	12	3"1/2	•	•	E	•	•																		
Xtreme																									OCHP
<b>Model 1301</b>																									
Tactical	12	3"	•	•	G	•									•										Fixed Cyl. OCHP
Competition	12	3"	•	•	B	•												•							OCHP
Competition Pro	12	3"	•	•	F																				OCHP
<b>Model A300 OUTLANDER</b>																									
Wood	12	3"	•		B	•																			MC
Synthetic	12	3"	•		E	•																			MC

Key:

**A:** anodized bronze  
**E:** anodized black or Camo

**B:** anodized black  
**F:** anodized blue

**C:** nickel plated  
**G:** anodized black or Cerakote®

**D:** Cerakote® and/or Camo

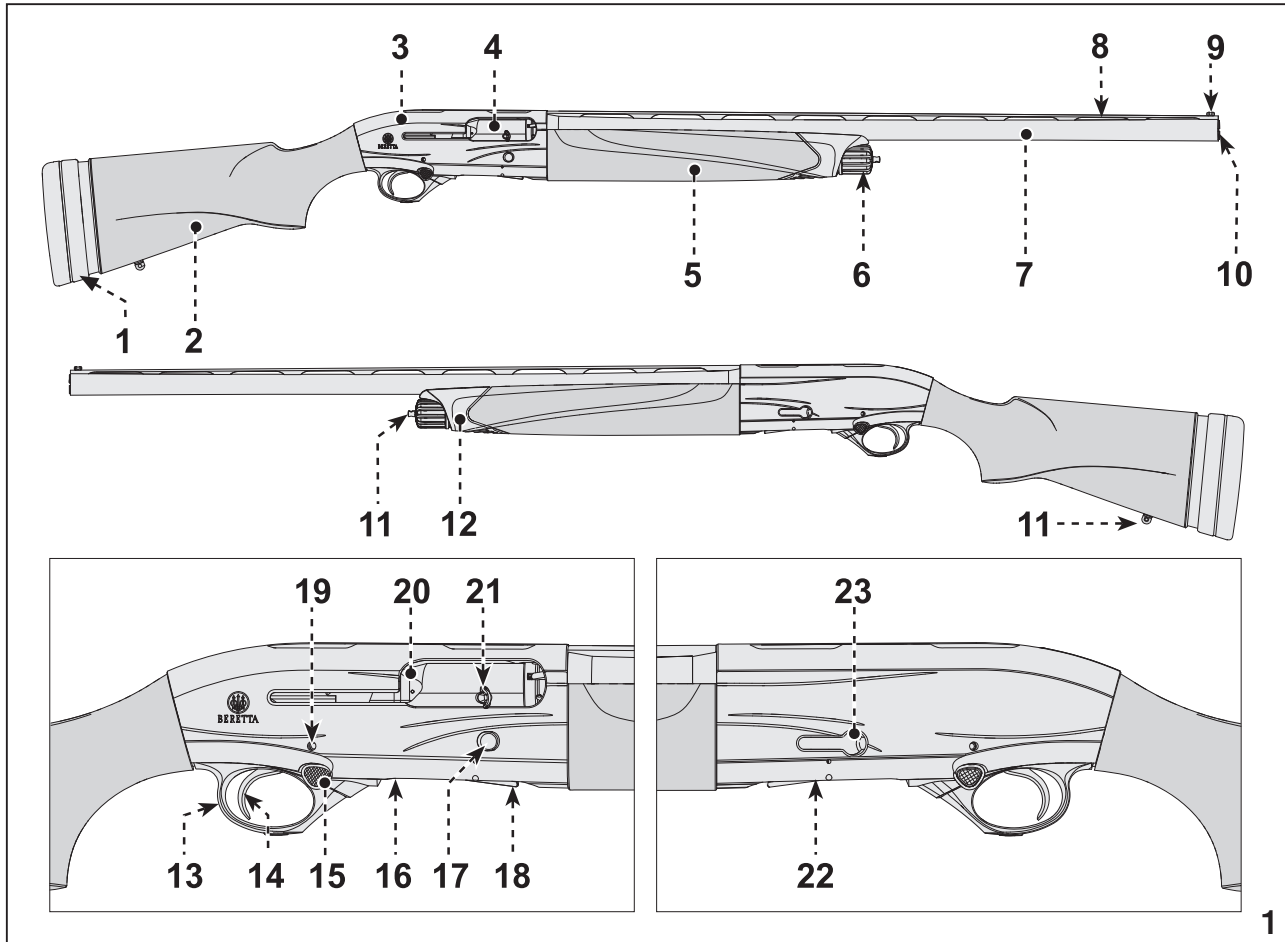

**NOMENCLATURE (FIGURES 1 - 1.1 - 1.2)**

- |   |                           |
|---|---------------------------|
| 1 Recoil pad with kick off (where fitted) | 19 trigger guard pin      |
| 2 stock                                   | 20 ejection port          |
| 3 receiver                                | 21 cocking handle         |
| 4 breech bolt assembly                    | 22 loading gate           |
| 5 fore-end                                | 23 cut-off (where fitted) |
| 6 fore-end cap                            | 24 barrel breech          |
| 7 barrel                                  | 25 gas piston             |
| 8 top rib                                 | 26 gas cylinder           |
| 9 sight                                   | 27 valve assembly         |
| 10 muzzle                                 | 28 choke                  |
| 11 sling mount                            | 29 choke spanner          |
| 12 fore-end flange with exhaust port      | 30 bolt head              |
| 13 trigger guard                          | 31 slide assembly         |
| 14 trigger                                | 32 magazine tube          |
| 15 safety button                          | 33 plug 2+1               |
| 16 carrier stop push button               | 34 cross magazine tube    |
| 17 breech bolt release button             | 35 fore-end cap           |
| 18 carrier                                |                           |

**With valve**

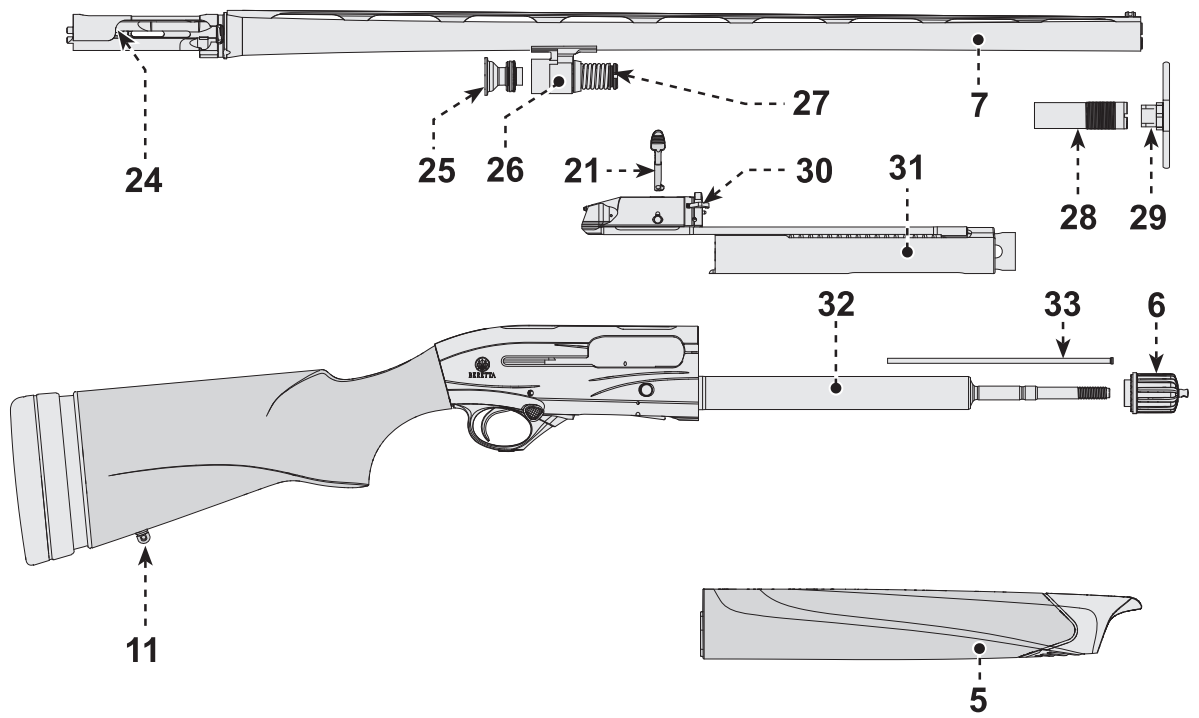

1.1

**With valve - cross magazine tube**

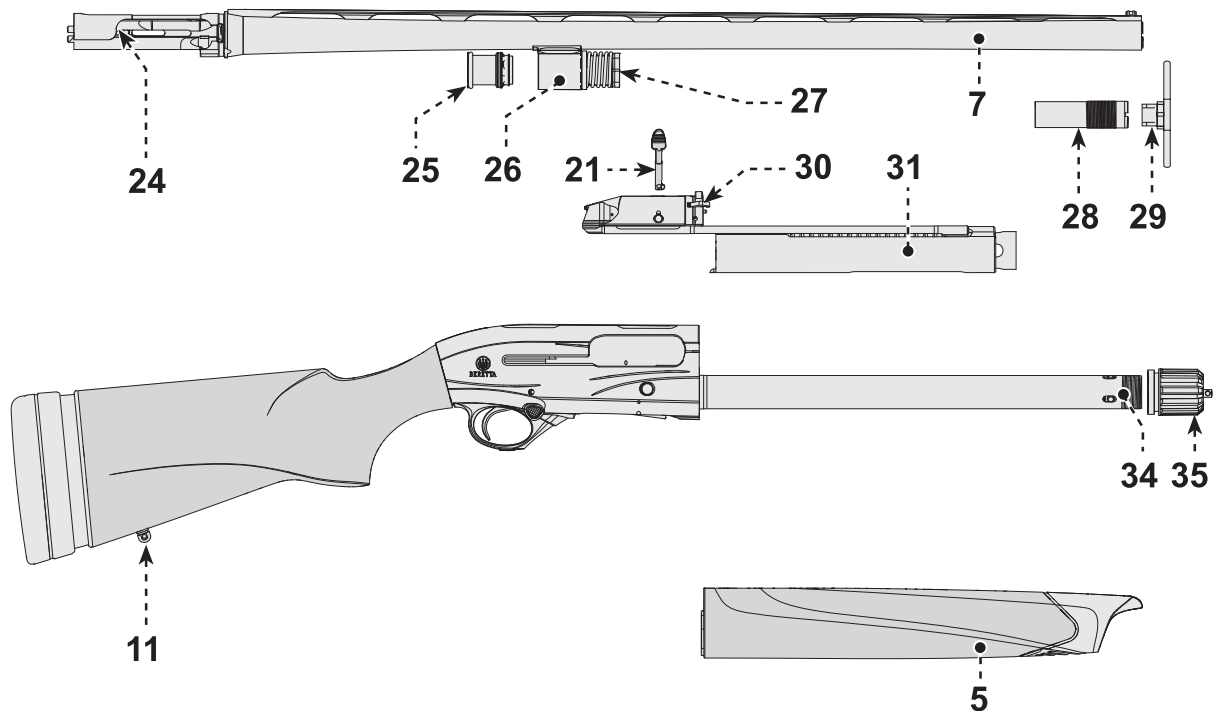

1.2

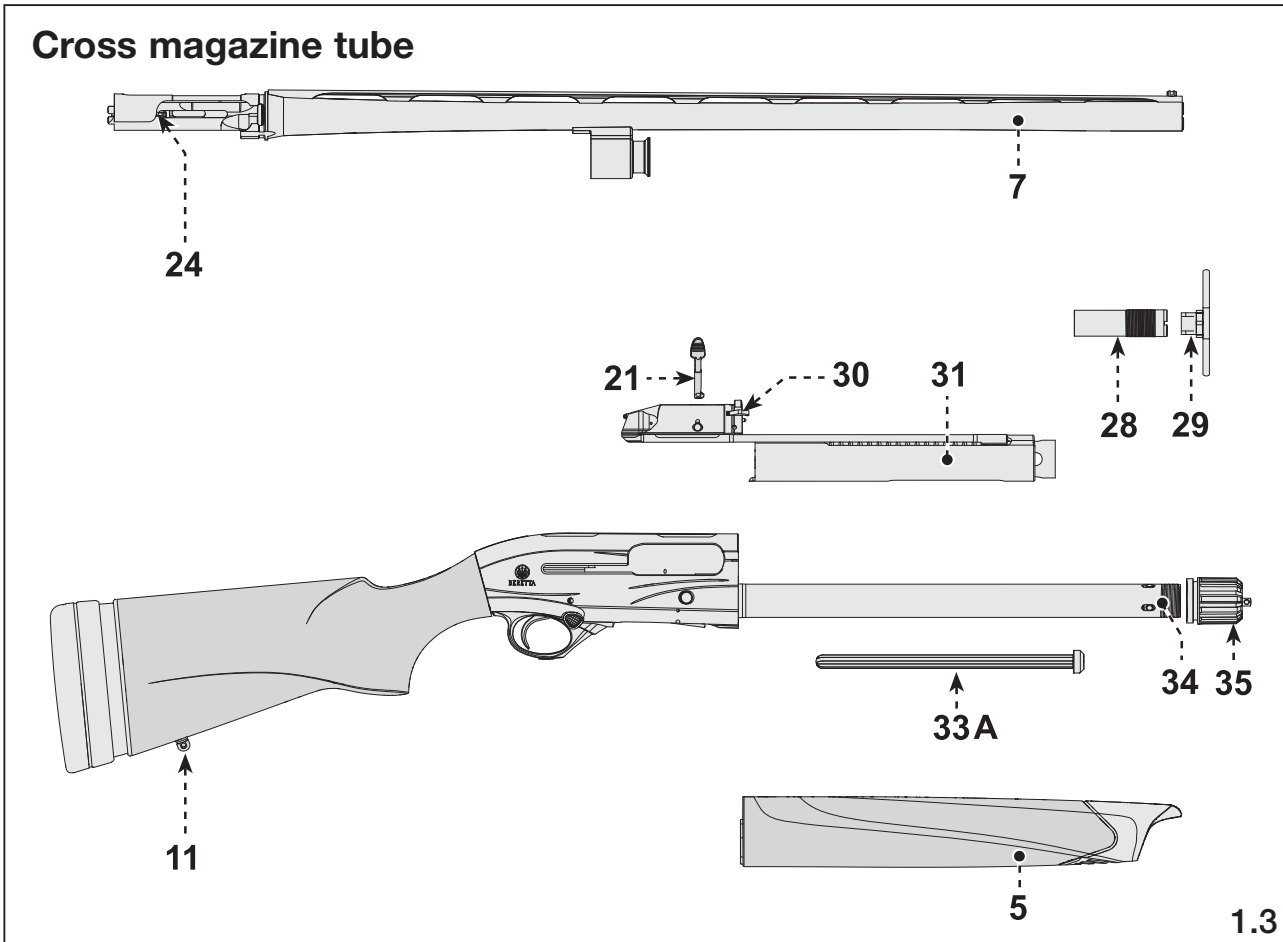

## NOMENCLATURE (FIGURES 1 - 1.3 - 1.4 - 1.5)

1	Recoil pad with kick off (where fitted)	19	trigger guard pin
2	stock	20	ejection port
3	receiver	21	cocking handle
4	breech bolt assembly	22	loading gate
5	fore-end	23	Cut-off (where fitted)
6	fore-end cap	24	barrel breech
7A	barrel	25	gas piston
8	top rib	26	gas cylinder
9	sight	27	valve assembly
10	muzzle	28	choke
11	sling mount	29	choke spanner
12	fore-end flange with exhaust port	30	bolt head
13	trigger guard	31	slide assembly
14	trigger	32	magazine tube
15	safety button	33	plug 2+1
16	carrier stop push button	33A	cross magazine tube plug
17	breech bolt release button	34	cross magazine tube
18	carrier	35	fore-end cap



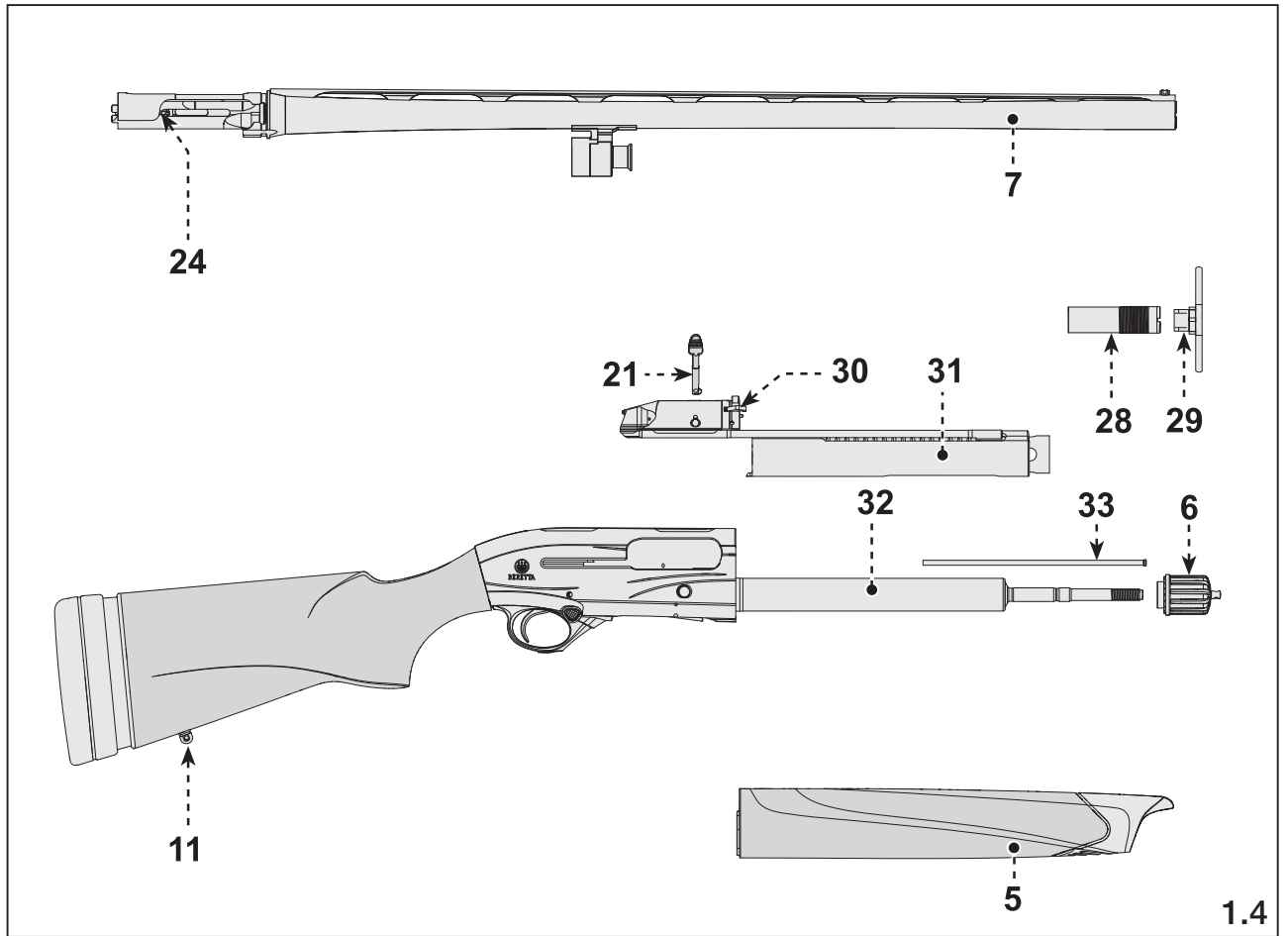

### A300 OUTLANDER

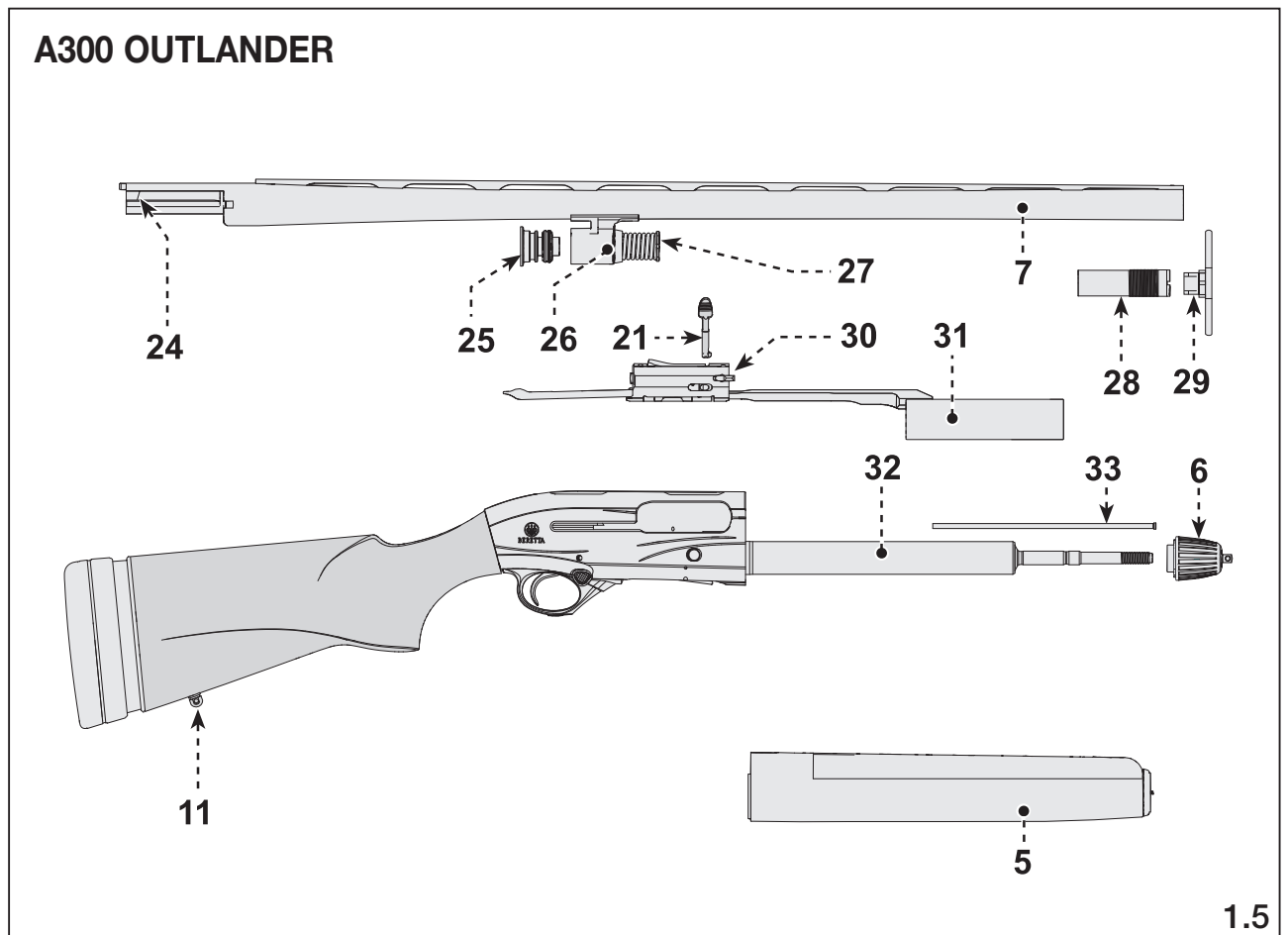

## OBSTRUCTION / CHOKE TUBES CONDITION CHECK

Check the barrel to ensure there are no obstructions in the chamber and bore. This is extremely important because serious injury can result to the user or to nearby persons if a cartridge is fired in an obstructed barrel or chamber.

Check the inside of the barrel prior to completely assembling the firearm and before use; if the firearm is already assembled the following procedure should be followed:

- Follow the instructions in the “Stripping” section on page 33 and remove the barrel from the shotgun.
- After removing the barrel, look right through it from the rear and make sure there are no obstructions of any type, even minor ones.
- If an obstruction in the barrel is detected, a competent gunsmith must remove it and inspect the shotgun again before it can be fired.
- Refit the barrel, following the instructions set out in the “Assembly” section below.

## CHECKING THE CONDITION OF THE CHOKE TUBES

- Always check the appearance and cleaning of the choke tubes before using the shotgun.
- Check the correct tightness in the barrel with the spanner provided.
- Never use choke tubes that show signs of defects, warping or incrustation.
- Make sure that the choke tube inserted is appropriate for the intended use and shot type to be used (steel or lead).

## ASSEMBLY

### **WARNING**

**ALL ASSEMBLY, STRIPPING AND MAINTENANCE PROCEDURES SHOULD BE CARRIED OUT WITH THE FIREARM UNLOADED (CARTRIDGE CHAMBER, RECEIVER AND MAGAZINE EMPTY). INSPECT THE FIREARM BY LOOKING THROUGH THE EJECTION PORT, THE LOADING GATE AND THE CHAMBER.**

### **WARNING**

**DURING ASSEMBLY, STRIPPING AND MAINTENANCE PROCEDURES, NEVER POINT A FIREARM AT SOMEONE OR AT HARD OR FLAT SURFACES. ALWAYS TREAT THE FIREARM AS IF IT WERE LOADED (SEE POINTS 1, 2 AND 4 OF THE BASIC SAFETY RULES).**

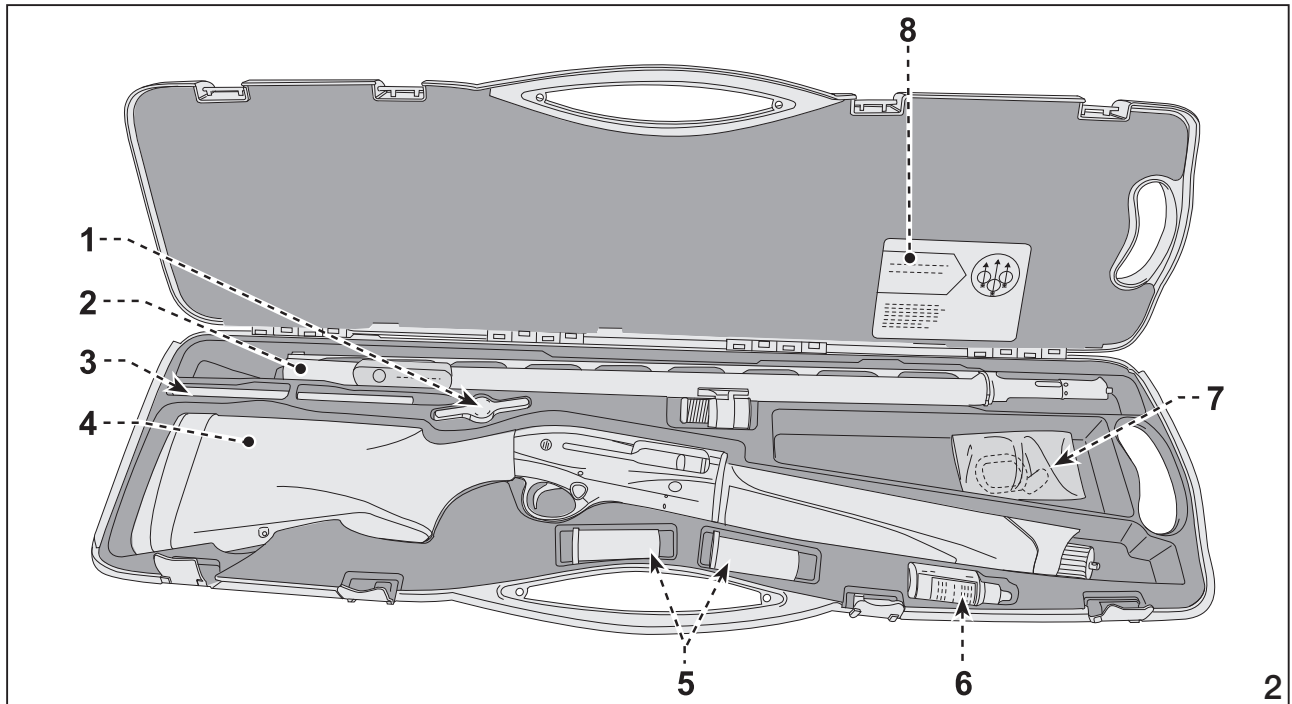

**IN THE CASE - FIG. 2**

### **i Notice**

The items supplied may vary according to shotgun model.

- 1 choke spanner (where provided)
- 2 barrel assembly
- 3 plug 1+1
- 4 stripped firearm
- 5 chokes (where provided)
- 6 Beretta gun oil
- 7 drop shims and slings (where provided)
- 8 technical documents

The Beretta semiautomatic shotgun (hereinafter referred to as “shotgun”) comes with barrel and stock-receiver-fore-end assembly disassembled.

### **ASSEMBLY PROCEDURE**

Fit the barrel onto the stock-receiver-fore-end assembly as described below.

### **CAUTION**

**It is advisable to carry out the assembly operations over a table to catch any components if they are dropped.**

### **i Notice**

**On 1301 Tactical and Competition models, shotguns are supplied fully assembled.**

### **CAUTION**

**In the unlikely event that the breech bolt assembly is in the unlocked position, do not press the release button and keep your finger away from the ejection port.**

**When the release button is pressed, the breech bolt is pushed forward by the recoil spring, until it is stopped at the ejection port by the cocking handle, with the likelihood of damage to both parts.**

- Check the barrel. The barrel and cartridge chamber must be clean and free from obstructions (see “Checking for obstructions” on page 16).
- Check that the choke tube is inserted in the barrel and tightened correctly, clean and in good condition (see “Checking the condition of the choke tubes” on page 16).

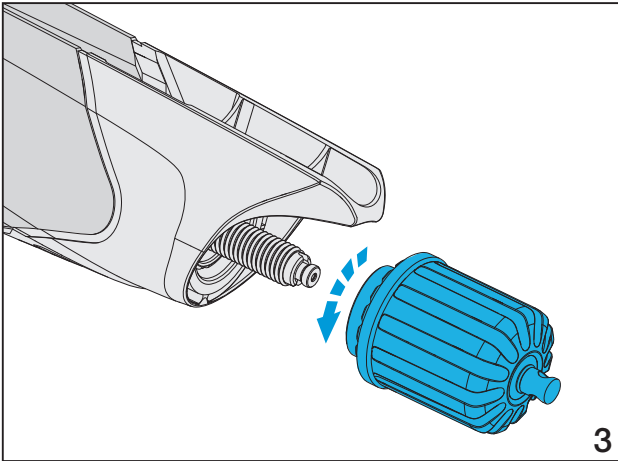

3

- Unscrew the front cap of the fore-end in an anticlockwise direction:  
**fig. 3.1 shotgun with cross magazine tube (B-LOK)**

- Carefully pull and slide the fore-end away from the receiver to completely remove it:  
**fig. 4 shotgun A400**  
**fig. 4.1 shotgun A300 OUTLANDER**

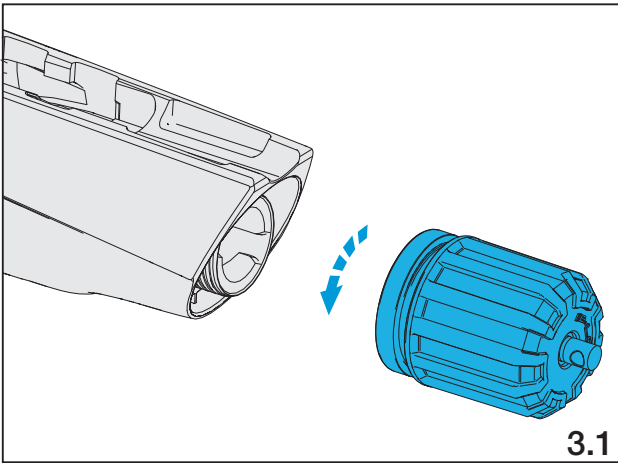

3.1

 **CAUTION**

In case of difficulty when sliding the fore-end, do not force it and please proceed as follows:

- Using the cocking handle, retract the breech bolt approximately 2cm within the receiver, then gently pull and slide the fore-end away whilst simultaneously holding the bolt in this position:

**fig. 5 shotgun A400**

**fig. 5.1 shotgun A300 OUTLANDER**

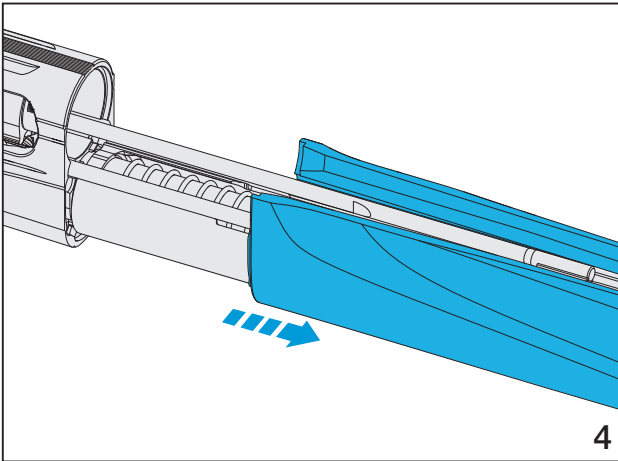

4

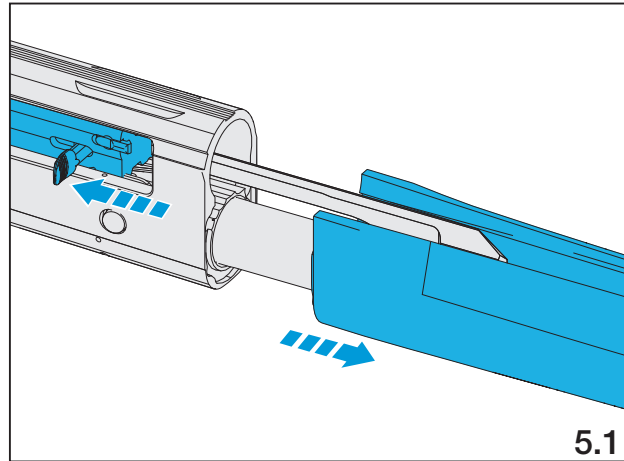

5.1

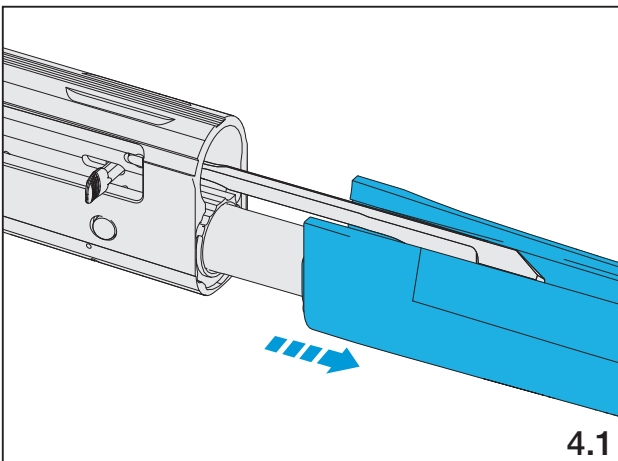

4.1

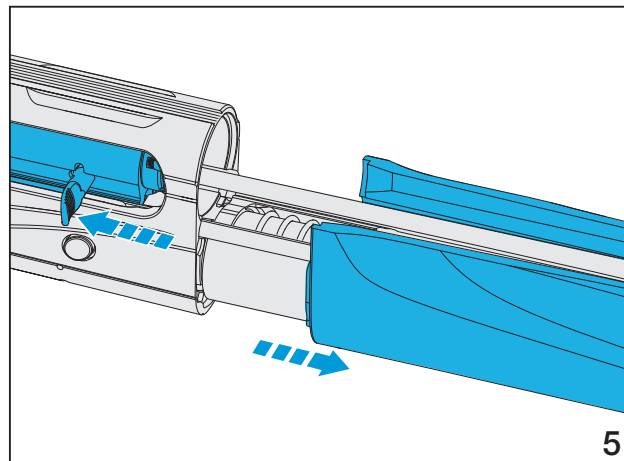

5

Once the fore-end is removed return the bolt gently to the closed position.

**fig. 6 shotgun without valve**  
**fig. 6.1 shotgun with valve**

- Check that the piston is positioned inside the gas cylinder of the barrel (fig. 6.1). If the piston is fitted to the magazine tube, remove it (fig. 7) and insert it into the barrel cylinder, making sure to tighten the elastic seal with your fingers to facilitate insertion of the piston into the cylinder (fig. 8).



## CAUTION

In order to prevent damage to the elastic piston seal, first insert the piston into the barrel cylinder and then insert the magazine tube shaft through the piston hole.

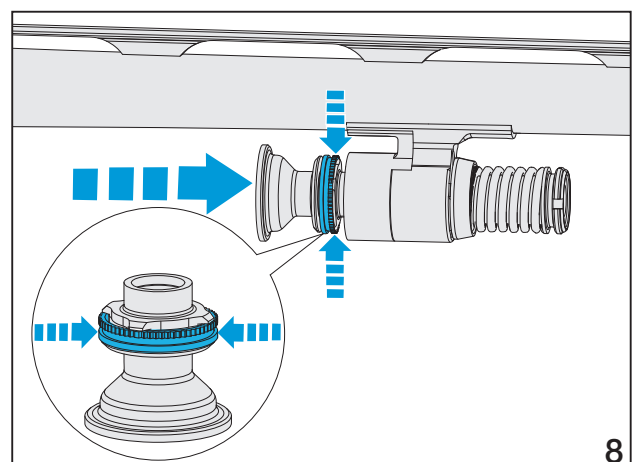
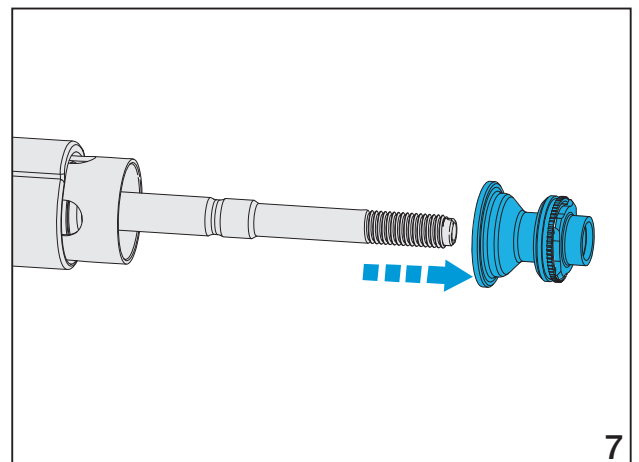
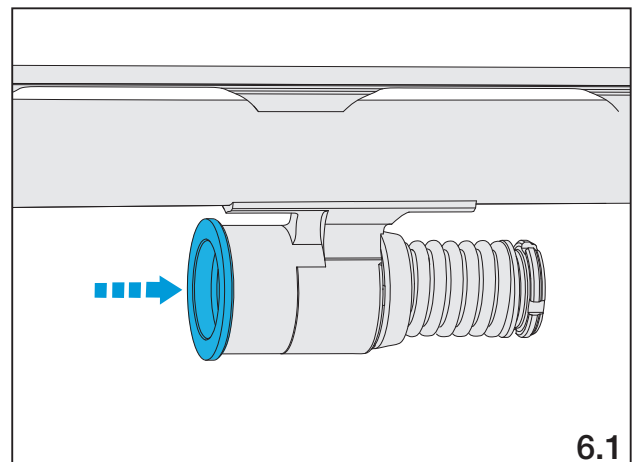
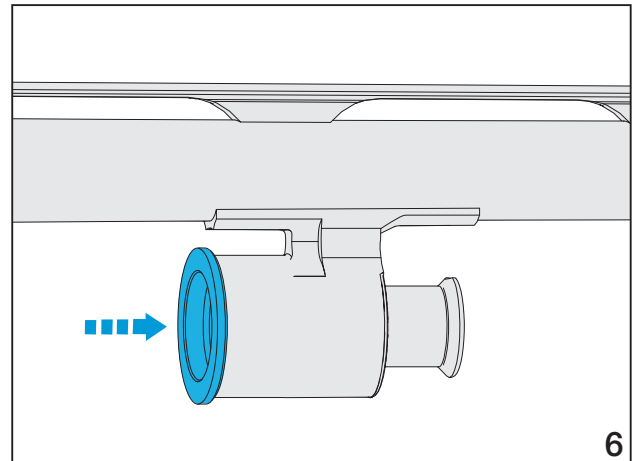

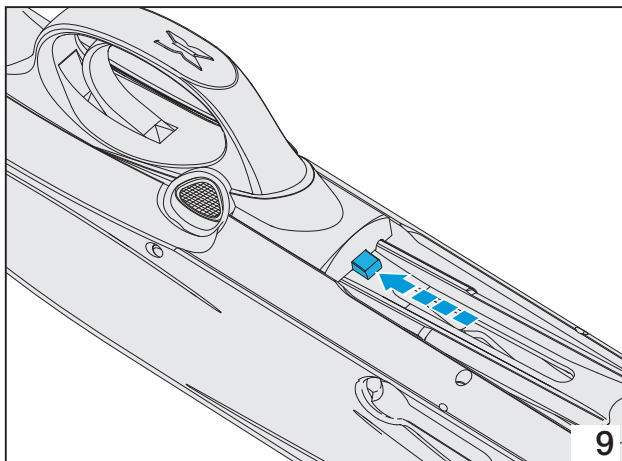

- Check that the carrier stop push button is pressed all the way down. If it is not, push it all the way down (fig. 9).
- Use the cocking handle to retract the breech bolt until it snaps into the open position (fig. 10).

 **CAUTION**

When the release button is pressed, the breech bolt is pushed forward by the recoil spring, until it is stopped at the ejection port by the cocking handle, with the likelihood of damage to both parts.

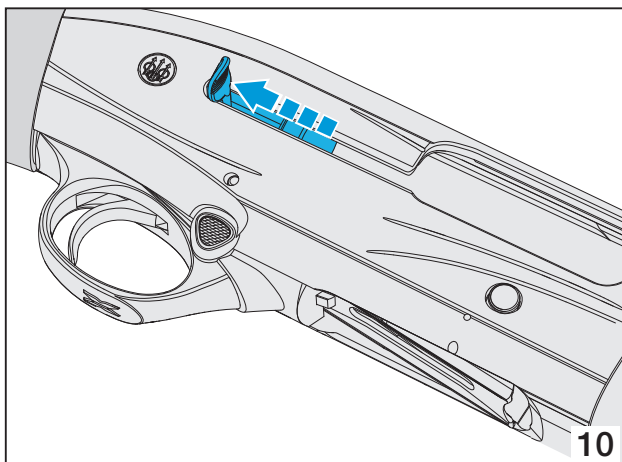

- Insert the barrel into the receiver (fig. 11), ensuring that the magazine tube shaft enters the piston hole as well as the gas cylinder hole with the valve assembly:

**fig. 12.1 shotgun with cross magazine tube**

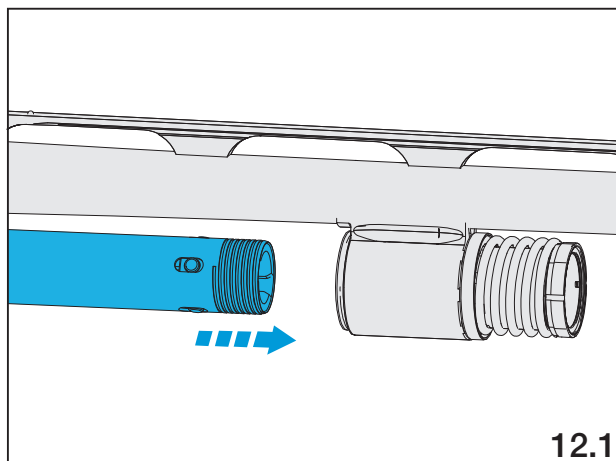
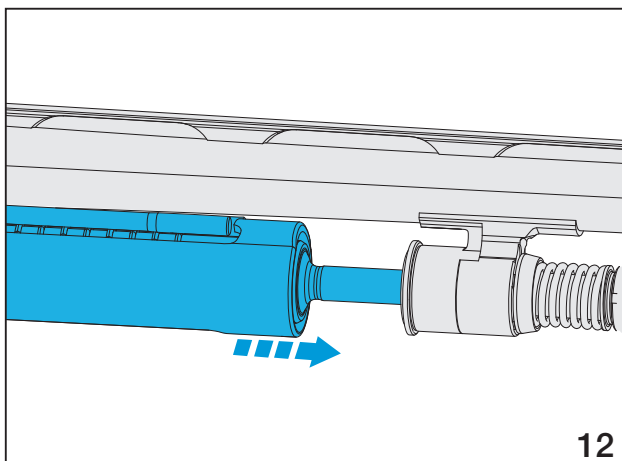
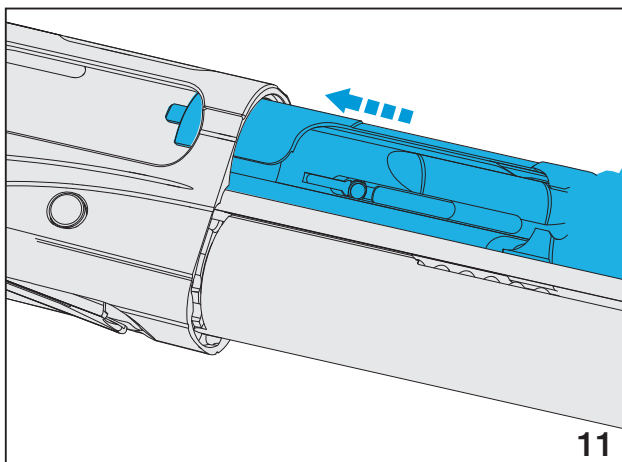

- Push the barrel all the way into the receiver until it stops.
- Slide the fore-end into place over the gas cylinder with valve and magazine tube (fig. 13) checking for the correct centering on the receiver face. The fore-end is in the correct position when it is all the way up to the receiver face (fig. 14).
- Tighten the front cap of the fore-end all the way:

**fig. 15.1 shotgun with cross magazine tube (B-LOK)**

- Keep your fingers away from the ejection port, press the breech bolt release button and guide the breech bolt to the lock position (fig. 16).

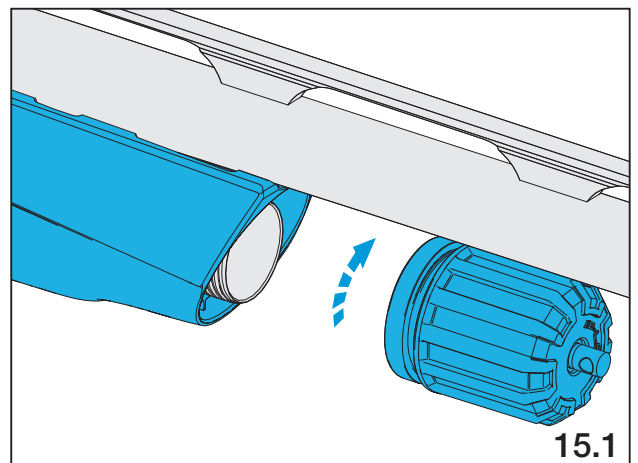
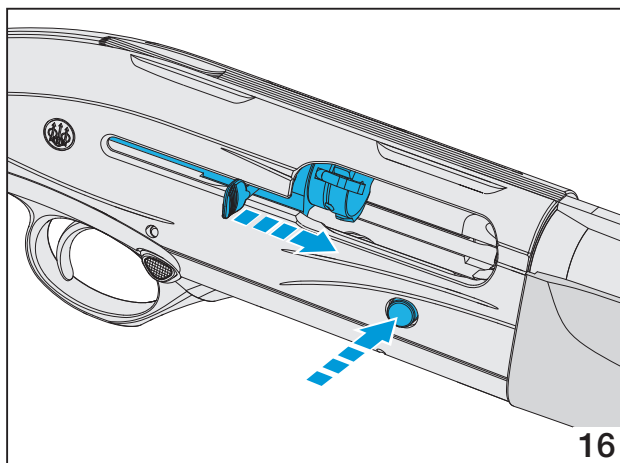
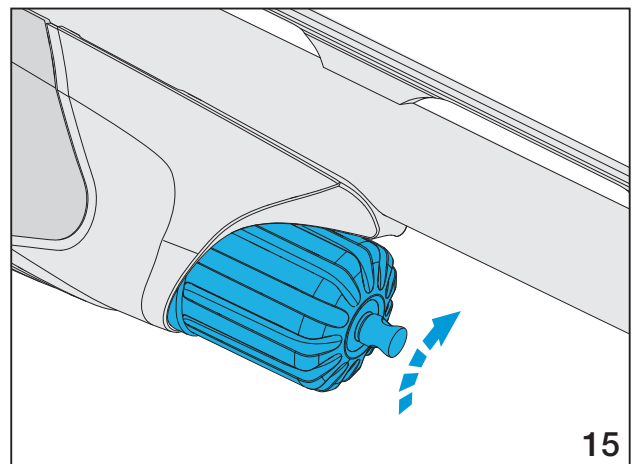
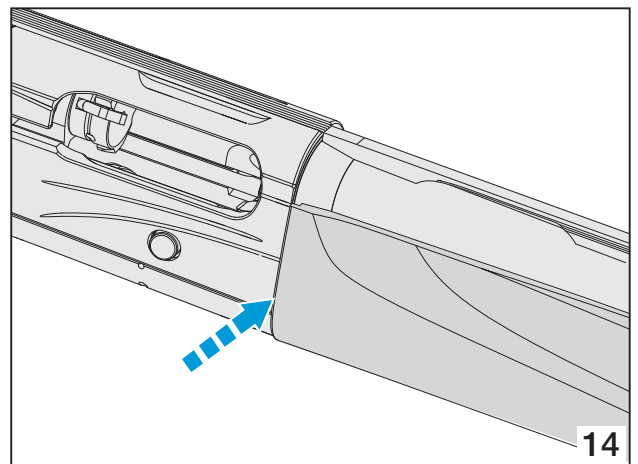
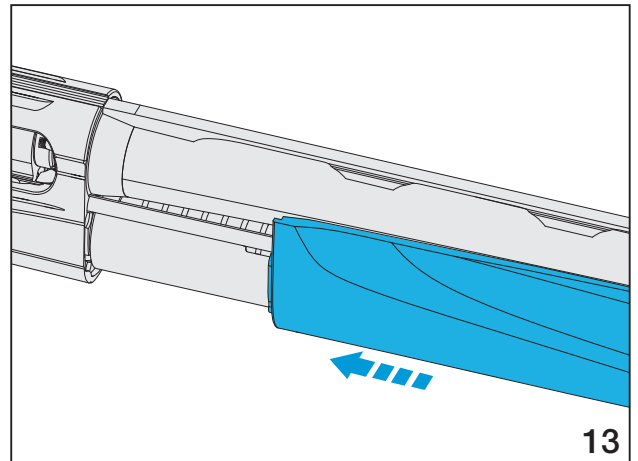

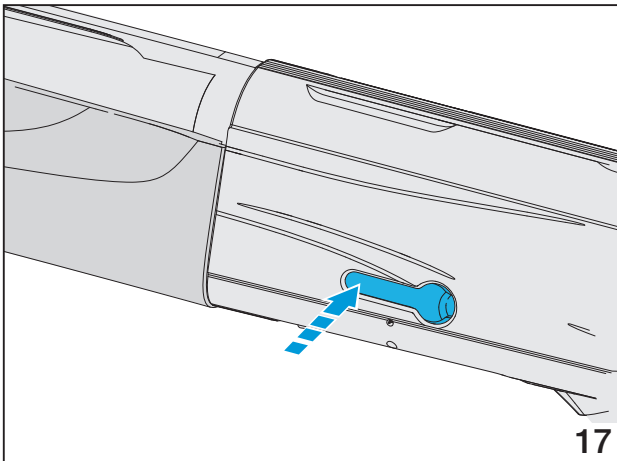

## CAUTION

When pressing the release button to close the breech bolt, be sure to not accidentally engage the cut-off lever (where present). If this occurs, the breech bolt will be kept in the unlocked position by the cut-off lever. In this case, lock the breech bolt while disengaging the cut-off lever. Keep your fingers away from the ejection port (fig 17).

- Keeping the breech bolt retracted 2 cm, pull the trigger to decock the hammer (18.1).

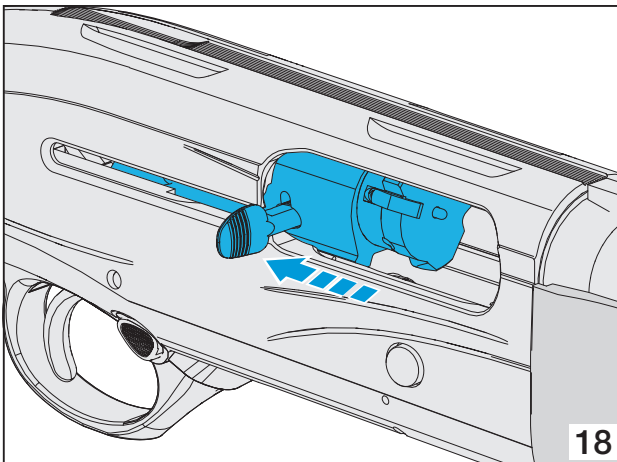

## WARNING

**THE SAFETY CAN ONLY BE INSERTED WITH THE HAMMER COCKED. THE HAMMER IS COCKED BY PULLING BACK THE BREECH BOLT. WHEN THE SAFETY BUTTON SHOWS THE RED RING, THE SAFETY IS DISENGAGED, SO THE FIREARM IS READY FOR USE. WHEN THE RED RING IS NOT VISIBLE ON THE SAFETY BUTTON, THE SAFETY IS ENGAGED.**

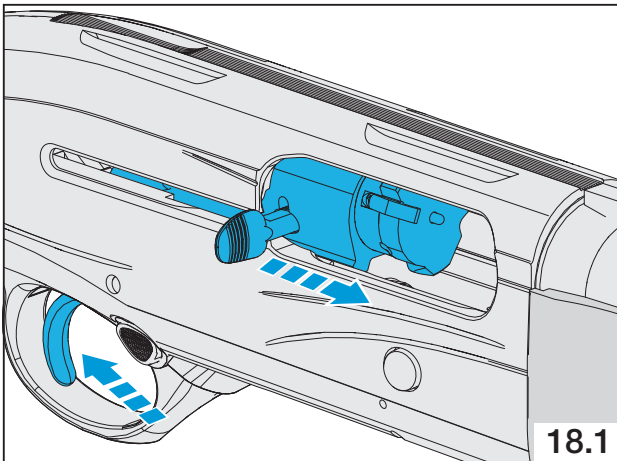



## LOAD CHECK

At various points in this manual, you will be requested to inspect the ejection port, the loading gate, and the cartridge chamber of your shotgun to ensure that it is unloaded. This should become second nature to you, as should the following precautions:

- Never assume that the gun is unloaded.
- Never point or push the gun toward yourself or another person.
- Always inspect the ejection port, the loading gate and the cartridge chamber to make sure they are empty. The cartridge chamber is the portion of the barrel into which the cartridge is inserted (fig. 19).
- Pull back the breech bolt to lock it into the open position and engage the safety before handing the shotgun to another person.
- Never take from or give the shotgun to another person unless the breech bolt has been opened and the ejection port, loading gate and cartridge chamber have been inspected to ensure they are completely empty.

Inspect the ejection port, the loading gate and cartridge chamber as indicated below:

### **WARNING**

**KEEP YOUR FINGER OFF THE TRIGGER AND KEEP THE BARREL POINTED IN A SAFE DIRECTION.**

- Check that the carrier stop pin is pressed all the way down. If it is not, push it all the way down (fig. 9).
- Use the cocking handle to retract the breech bolt until it snaps into the open position (fig. 10).

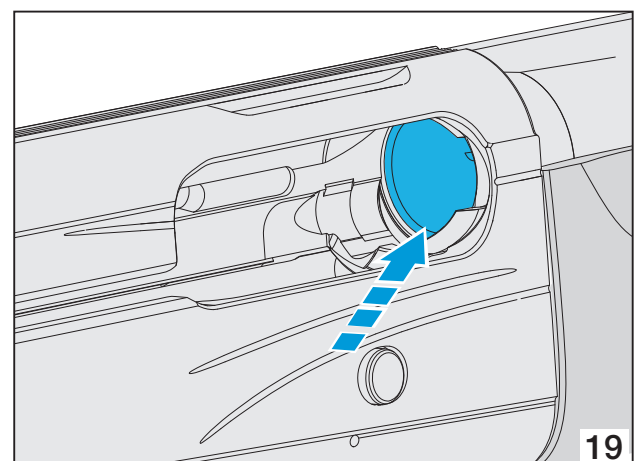

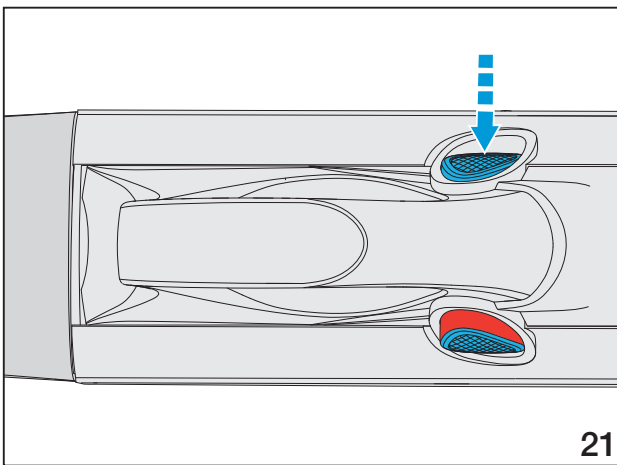
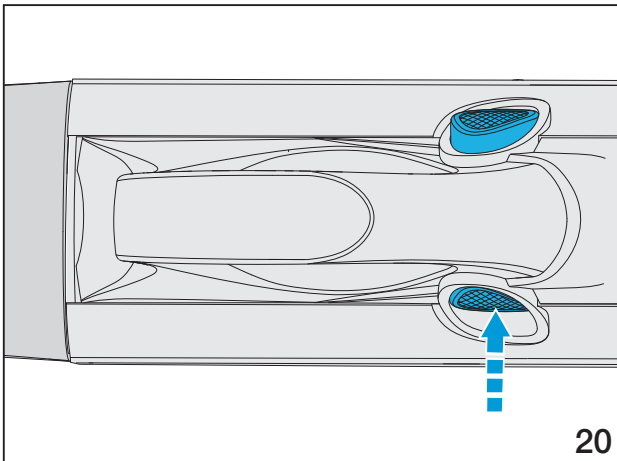

- Engage the manual safety by pressing the safety button to hide the red ring (fig. 20).
- Inspect the firearm by looking through the ejection port, the loading gate and the cartridge chamber. They must be empty. Check that there are no cartridges in the magazine tube. If there are, unload the firearm as indicated in “How to unload the firearm” on page 31.
- Press the breech bolt release button and gently guide it to the locked position (fig. 16).
- Disengage the safety (fig. 21) (red ring visible) and hold the breech bolt back about 2cm, pull the trigger to decock the hammer.

### **WARNING**

**WHEN THE SAFETY BUTTON SHOWS THE RED RING, THE SAFETY IS DISENGAGED, SO THE FIREARM IS READY FOR USE. WHEN THE RED RING IS NOT VISIBLE ON THE SAFETY BUTTON, THE SAFETY IS ENGAGED.**

## USE AMMUNITION

### **WARNING**

**BERETTA ASSUMES NO LIABILITY FOR PHYSICAL INJURY OR PROPERTY DAMAGE RESULTING FROM THE USE OF DEFECTIVE, IMPROPER, HAND-LOADED, RELOADED OR REMANUFACTURED AMMUNITION. SERIOUS DAMAGE OR INJURY, EVEN DEATH, MAY BE CAUSED FROM THE USE OF AMMUNITION THAT IS NOT SUITABLE, LOADED WITH FORCE, OR LOADED WITH OBSTRUCTIONS IN THE BARREL. THE USE OF RELOADED AMMUNITION WILL VOID THE MANUFACTURER'S WARRANTY. ONLY USE TOP-QUALITY, FACTORY-LOADED AMMUNITION.**

### **WARNING**

**TO PROTECT THE SHOTGUN AGAINST MALFUNCTION, INSPECT EACH CARTRIDGE BEFORE INSERTING IT INTO THE CHAMBER. MAKE SURE THAT THE CASE-HEADS ARE NOT DAMAGED OR DEFORMED AND THAT THE CARTRIDGES HAVE NO OTHER TYPE OF DENT OR DEFECT (THESE CHECKS MUST ALSO BE MADE FOR FACTORY-NEW AMMUNITION).**

- The shotgun has different cartridge chambers, depending on the version. The shotgun does not require adjustments or interventions to shoot from 70 mm (2 3/4 in) /24 g (7/8 oz), to 76 mm (3 in) /57 g (2 oz) cartridges.
- The “UNICO/XTREME” version without any adjustments or interventions can shoot from 70 mm (2 3/4 in) /24 g (7/8 oz) to the powerful Supermagnum 89 mm (3 in) /64 g (2.1/4 oz) loads.

- **Beretta recommends:** To immediately obtain superior firearm performance and optimum cartridge versatility from your shotgun, fire some medium power cartridges first (32 g / 1.1/8 oz).

### **CAUTION**

The shotgun has an Optima-Bore® HP barrel and Optimachoke® HP choke tubes that make it possible to fire High Performance steel shot ammunition. Follow the instructions for use of choke tubes appropriate for the use of steel shot, as set out in the “Steel shot” section on page 26.

- You will find the markings for the gauge and chamber length for your shotgun on the side of the barrel (fig. 22).
- Every shotgun has been tested with special proof test ammunition at 1320 bar with high performance steel shot. These tests guarantee the ability to shoot either ordinary or HP steel shot (usually higher than 3.5 mm of diameter) which cause higher pressure in the barrel.

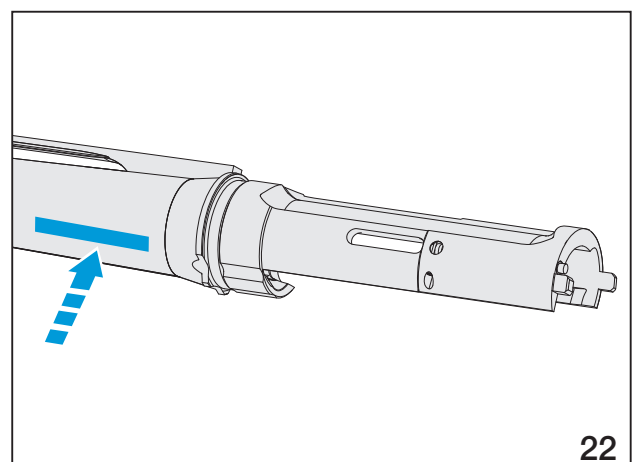

22

 **WARNING**

**NEVER USE CARTRIDGES THAT DO NOT CORRESPOND TO THE INDICATIONS ON THE BARREL.**

 **WARNING**

**ALWAYS USE CARTRIDGES WITH A LENGTH EQUAL TO OR LESS THAN THE LENGTH OF THE CHAMBER STATED ON THE BARREL.**

 **WARNING**

**TO AVOID USING IMPROPER AMMUNITION, ALWAYS CHECK THE CHARACTERISTICS STAMPED ON THE CARTRIDGE BOX AND ON THE CARTRIDGE. BE SURE TO USE THE RIGHT CARTRIDGE GAUGE AND LENGTH FOR YOUR SHOTGUN.**

**STEEL SHOT**

All Beretta barrels, as well as the “SP” (Steel Proof) Beretta choke tubes, are designed for use with factory steel shot cartridges loaded to international standard specifications.

When steel shot cartridges are fired, the best results are obtained by using open chokes (C0000/CL, 0000/IC, 000/M).

Full choke constrictions (0/F, 00/M) when using steel shot, do not increase pattern density and will distort normal pattern density, accelerating wear and tear.

The use of reloaded or remanufactured ammunition can increase the likelihood of excessive pressure, case rupture or other defects in the ammunition.

**MAGAZINE CAPACITY**

The shotgun magazine has a capacity limited to 2 shots, in line with the current hunting regulations in many countries, due to the insertion of a reducer.

This reducer restricts firearm use to no more than three rounds (two in the magazine, and one in the cartridge chamber).

This device is fitted by Beretta during manufacture and assembly of the shotgun.

If local laws require the capacity to be limited to 2 rounds in total (one in the magazine and one in the chamber), Beretta adds a “1+1” reducer to the package, to replace the reducer fitted in the factory.

 **CAUTION**

**Wholesalers, dealers or gunsmiths are not authorized to carry out any Warranty repair or adjustment on behalf of the Manufacturer (unless they are a Repair Point authorized by the Manufacturer and/or by its Local Official Distributors).**

## HOW TO LOAD AND FIRE

### **WARNING**

**BEFORE LOADING THE FIREARM, IT IS A GOOD IDEA TO PRACTICE THE FOLLOWING LOADING PROCEDURES WITHOUT THE USE OF AMMUNITION. NEVER HANDLE A LOADED FIREARM UNTIL YOU ARE FULLY FAMILIAR WITH THE LOADING PROCEDURES. ALWAYS INSPECT THE EJECTION PORT, THE LOADING GATE AND THE CARTRIDGE CHAMBER TO MAKE SURE THEY ARE EMPTY. CHECK THAT THERE ARE NO CARTRIDGES IN THE MAGAZINE TUBE. BEFORE LOADING THE FIREARM, ENSURE THAT THE SAFETY IS ENGAGED. ALWAYS KEEP THE FIREARM POINTED IN A SAFE DIRECTION. (SEE POINTS 1, 2 AND 4 OF THE BASIC SAFETY RULES).**

### **CAUTION**

Always check the barrel before loading the firearm to make sure that it is clean and free of possible obstructions (see: “Checking for obstructions” on page 16).

### **CAUTION**

Check the conditions and correct tightness of the choke tube in the barrel. Never use the shotgun without the choke tube inserted (see “Checking the condition of the choke tubes” on page 16).

Always keep your fingers away from the trigger guard, if you do not intend to shoot.

The shooter and all bystanders must always wear protective eye- wear and ear protection during shooting.

Residue from gunpowder, lubricant or metal fragments may be projected backwards and cause injury. Noise-reducing earplugs or earmuffs will reduce the risk of damage to hearing caused by prolonged shooting activity.

- Check that the carrier stop pin is pressed all the way down. If it is not, push it all the way down (fig. 9).
- Use the cocking handle to retract the breech bolt until it snaps into the open position (fig. 10).
- Engage the manual safety by pressing the safety button to hide the red ring (fig. 20).

### **WARNING**

**THE SAFETY CAN ONLY BE INSERTED WITH THE HAMMER COCKED. THE HAMMER IS COCKED BY PULLING BACK THE BREECH BOLT. WHEN THE SAFETY BUTTON SHOWS THE RED RING, THE SAFETY IS DISENGAGED, SO THE FIREARM IS READY FOR USE. WHEN THE RED RING IS NOT VISIBLE ON THE SAFETY BUTTON, THE SAFETY IS ENGAGED.**

### **WARNING**

**THE MANUAL SAFETY IS MERELY A MECHANICAL DEVICE AND IS IN NO WAY A SUBSTITUTE FOR THE BASIC SAFETY RULES OF FIREARM HANDLING.**

- Introduce the first cartridge into the cartridge chamber through the ejection port (fig. 23).
- Keeping your hands away from the ejection port, press the release button and guide the breech bolt to lock (fig. 24).

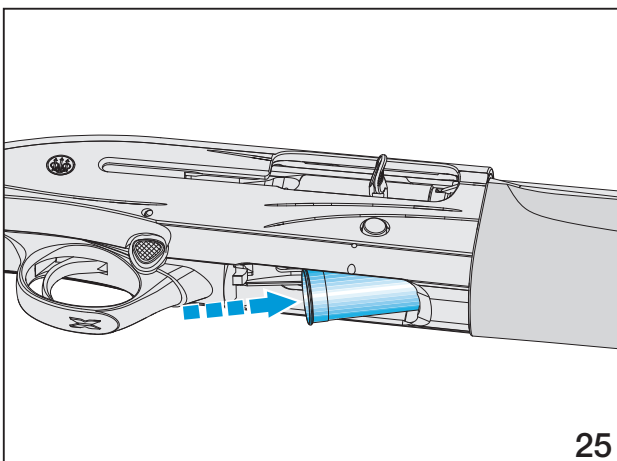
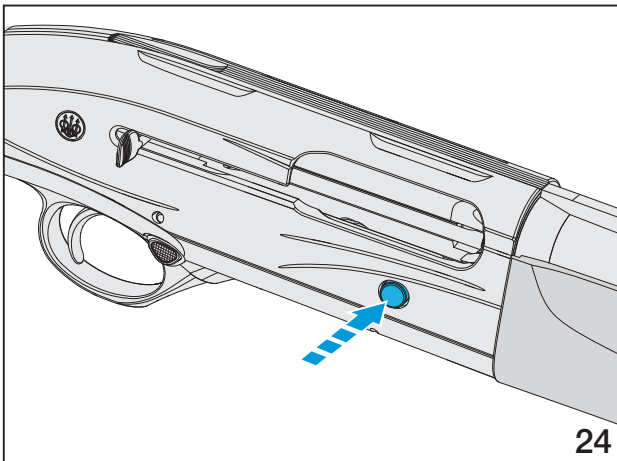
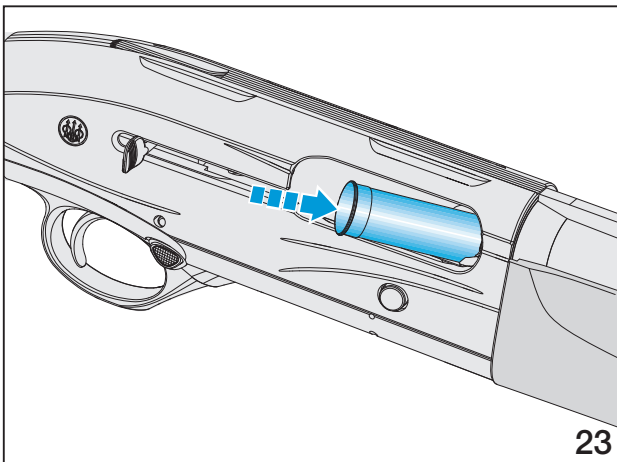

## **WARNING**

**THE FIREARM IS NOW LOADED AND READY TO FIRE AFTER THE MANUAL SAFETY IS DISENGAGED. ALWAYS KEEP YOUR FINGER OFF THE TRIGGER AND AVOID CONTACT WITH THE TRIGGER BY OTHER OBJECTS IF YOU DON'T INTEND TO FIRE. NEVER POINT A FIREARM AT SOMETHING THAT IS NOT SAFE TO SHOOT. (SEE POINTS 1, 2 AND 4 OF THE BASIC SAFETY RULES).**

## **WARNING**

**BERETTA ASSUMES NO LIABILITY FOR ANY INJURY OR PROPERTY DAMAGE RESULTING FROM IMPROPER OR CARELESS HANDLING OR INTENTIONAL OR ACCIDENTAL FIRING OF THE SHOTGUN.**

## **Notice**

If the breech bolt remains in the unlocked position, check that the cut-off (where present) has not been inadvertently engaged. Keep your hands away from the ejection port and disengage the cut-off (fig.17).

- Move the carrier to insert the cartridges into the magazine through the loading gate to hook onto the cartridge retaining tooth (fig. 25).
- To shoot, disengage the safety (fig. 21) (red ring visible) and pull the trigger.
- After firing the first shot, release the trigger to set up the shotgun for the next round.
- The shotgun will fire the cartridge in the chamber first, and then it will automatically introduce the cartridge from the magazine tube into the chamber.

**! WARNING**

AFTER PULLING THE TRIGGER, IF THE SHOTGUN DOESN'T FIRE, ENGAGE THE SAFETY, WAIT AT LEAST ONE MINUTE AND UNLOAD THE SHOTGUN AS DESCRIBED IN THE CORRESPONDING SECTION.

NEVER ATTEMPT TO REUSE OR FIRE AMMUNITION THAT DID NOT FIRE THE FIRST TIME. DISPOSE OF UNFIRED OR DAMAGED AMMUNITION PROPERLY, IN ACCORDANCE WITH THE AMMUNITION MANUFACTURER'S RECOMMENDATIONS.

**! WARNING**

IF ANOTHER CARTRIDGE IS FIRED INTO AN OBSTRUCTED BARREL, DAMAGE AND VERY SERIOUS INJURY MAY OCCUR.

If you do not plan to fire a second shot, engage the safety (red ring not visible, fig. 20), keeping the firearm pointed in a safe direction and your fingers away from the trigger. If you have finished firing, unload the shotgun as indicated in: "How to unload the shotgun" on page 31.

- When the last cartridge has been fired, the breech bolt remains in the unlocked position, showing that the magazine is empty (fig. 26).
- Engage the shotgun safety (red ring not visible, fig. 20) and if necessary, reload the shotgun according to the instructions given previously.

**! WARNING**

ALWAYS UNLOAD THE FIREARM IMMEDIATELY AFTER FIRING IS COMPLETED. NEVER STORE A LOADED FIREARM. TO STORE THE SHOTGUN, SEE: "STORAGE" ON PAGE 67.

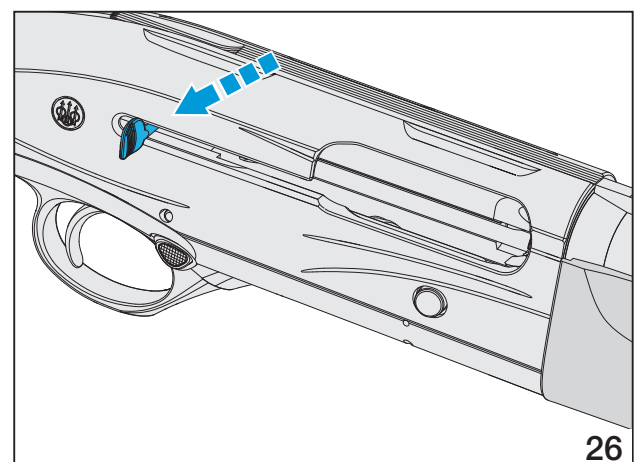

## HOW TO USE THE CUT-OFF DEVICE (WHERE PRESENT)

The cut-off is a safety device that makes it possible, when there is a cartridge in the chamber and in the magazine tube, to extract the live cartridge from the chamber without loading the next one and to keep the breech bolt in the open position.

### **! WARNING**

**FIREARM LOADED WITH CARTRIDGE IN THE CHAMBER AND SAFETY ENGAGED. NEVER POINT A FIREARM AT SOMETHING THAT IS NOT SAFE TO SHOOT. (SEE POINTS 1, 2 AND 4 OF THE BASIC SAFETY RULES).**

- Ensure that the safety is engaged (fig. 20). The red ring of the safety is not visible.

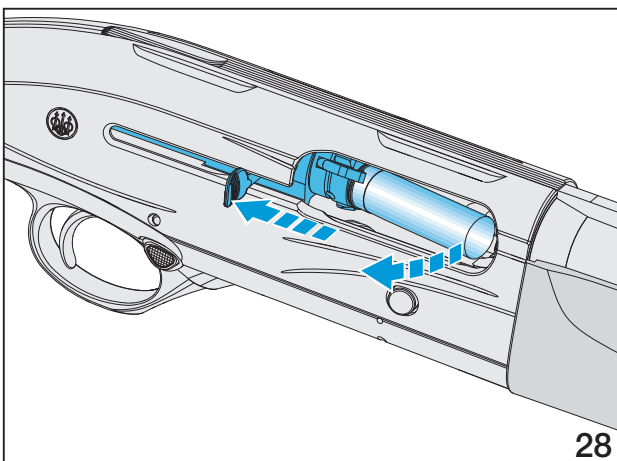
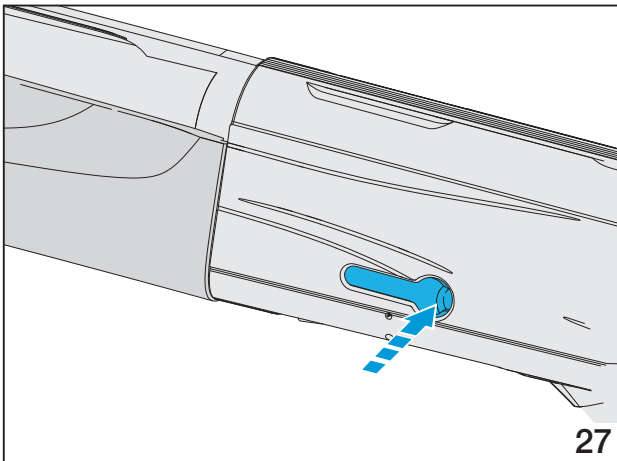

- Engage the cut-off device pressing the lever on the left side of the receiver (round part) (fig. 27).
- Retract the breech block back fully using the cocking handle. At this stage, the loaded cartridge will be extracted from the cartridge chamber and ejected through the ejection port (fig. 28), the breech bolt will stop on the carrier, blocked by the cut-off device. Feeding from the magazine is blocked.
- Once safety conditions are restored, insert the extracted loaded cartridge (fig. 23) or other type of cartridge required.
- Keeping your fingers away from the ejection port, disengage the cut-off device to release the breech bolt so that it locks (fig. 17).

### **! WARNING**

**THE FIREARM IS LOADED AND READY TO FIRE AFTER THE MANUAL SAFETY IS DISENGAGED. CHECK THAT THE SAFETY IS CORRECTLY ENGAGED. NEVER POINT A FIREARM AT SOMETHING THAT IS NOT SAFE TO SHOOT. (SEE POINTS 1, 2 AND 4 OF THE BASIC SAFETY RULES).**

- To shoot, disengage the safety (fig. 21) (red ring visible) and pull the trigger.

### **i Notice**

For correct functioning of the shotgun, the cut-off is to be used as described. In particular, it should be remembered that the breech bolt, held open by the cut-off device, must be closed, operating solely on the cut-off device itself.



## HOW TO UNLOAD THE SHOTGUN

### **WARNING**

**THE FIREARM IS LOADED AND READY TO FIRE. ALWAYS KEEP YOUR FINGER OFF THE TRIGGER AND AVOID CONTACT WITH THE TRIGGER BY OTHER OBJECTS IF YOU DON'T INTEND TO FIRE. NEVER POINT THE FIREARM AT SOMEONE OR AT HARD, FLAT SURFACES. (SEE POINTS 1, 2 AND 4 OF THE BASIC SAFETY RULES).**

- Keeping the firearm pointed in a safe direction, check that the safety is engaged (fig. 20) (red ring not visible).
- Engage the cut-off device (fig. 27) and retract the breech bolt to extract and eject the loaded cartridge from the chamber (fig. 28).
- Keep your fingers away from the ejection port, disengaging the cut-off device to release the breech bolt so that it locks (fig. 17).
- Raise the carrier, push the cartridge lightly into the magazine tube and at the same time press down the release button, guiding the cartridges out of the magazine tube.
- Keep your fingers away from the ejection port, and guide the breech bolt to the locked position.
- After checking the magazine tube and the receiver are empty, keeping the shotgun pointed in a safe direction, disengage the safety (fig. 21) (red ring visible).
- Keeping the breech bolt pulled back 2 cm, pull the trigger, thereby decocking the hammer.

## SHOTGUN WITHOUT CUT-OFF

- If there is no cut-off device, engage safety and retract the breech bolt all the way to extract and expel the live cartridge from the chamber.
- Press the carrier stop push button (fig. 28.1) and engage the safety (fig. 28.2).

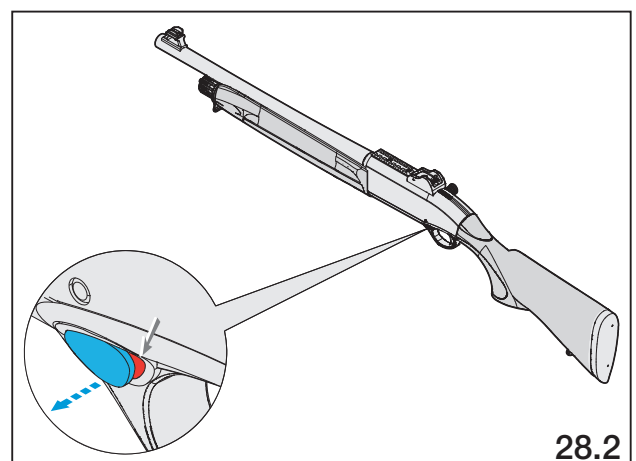
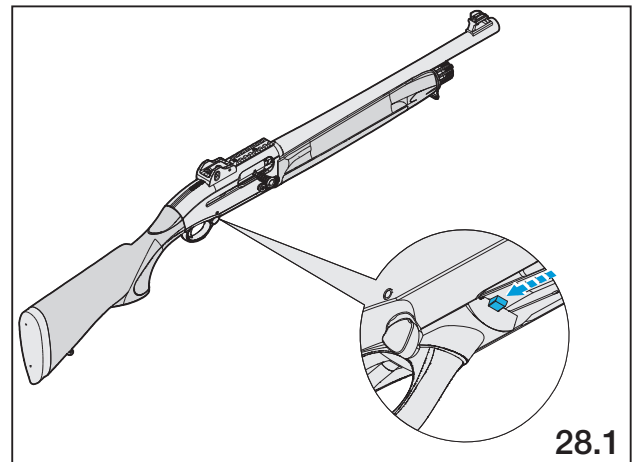

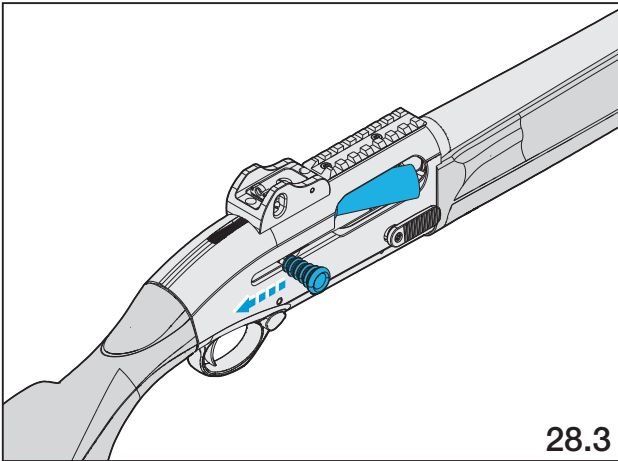

- Pull back the breech bolt to extract and eject the live cartridge from the chamber (fig. 28.3).
- If there are cartridges in the magazine tube, lift the carrier, gently push the cartridge into the magazine (fig. 28.4) while pressing the stop device (fig. 28.5), which will then eject the cartridge from the magazine (fig. 28.6). Repeat the procedure until the magazine is empty. After making sure that the shotgun is unloaded, retract the bolt about 2 cm (fig. 28.7), disengage the safety (fig. 28.8) and pull the trigger to decock the hammer.

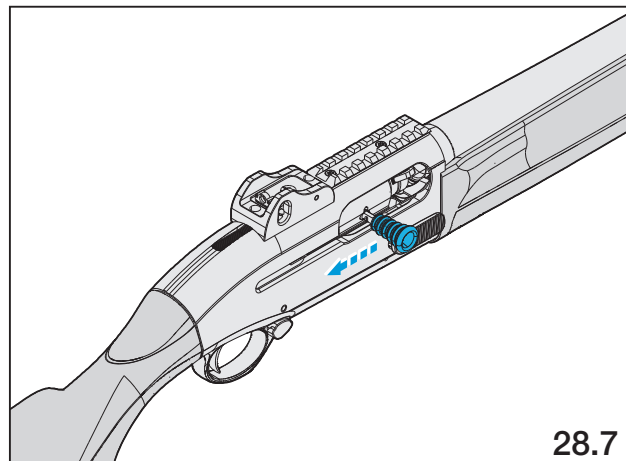
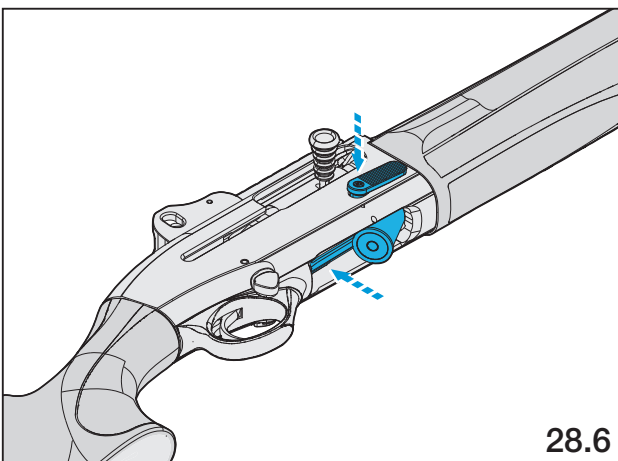
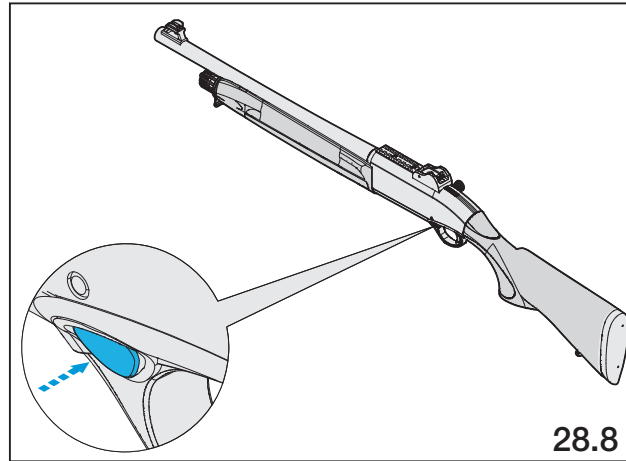
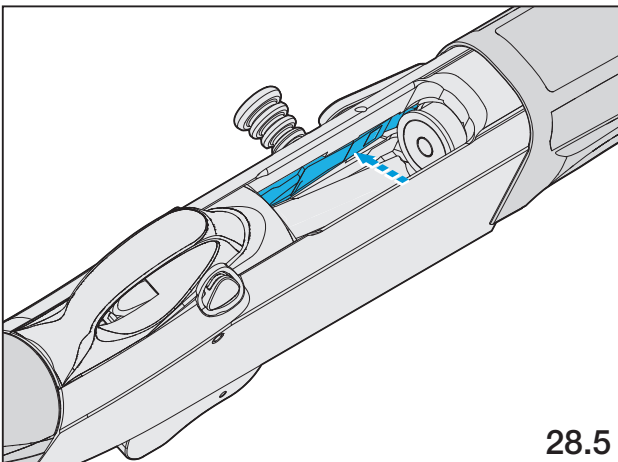
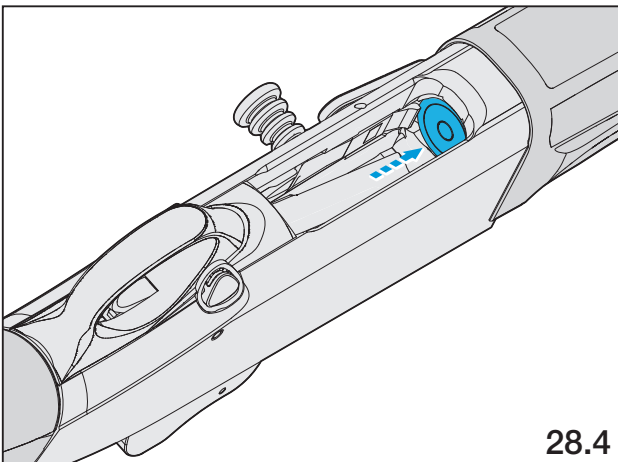

## FIELD STRIPPING

### **WARNING**

**ALWAYS CHECK THAT THE SHOTGUN IS UNLOADED (EMPTY CARTRIDGE CHAMBER, EMPTY RECEIVER, EMPTY MAGAZINE). INSPECT THE FIREARM BY LOOKING THROUGH THE EJECTION PORT, THE LOADING GATE AND THE CHAMBER. IF IT IS NOT EMPTY, UNLOAD IT AS INSTRUCTED IN THE RELEVANT SECTION. CHECK THAT THE HAMMER IS DECOCKED.**

### **WARNING**

**NEVER POINT THE FIREARM AT SOMEONE OR AT HARD, FLAT SURFACES. ALWAYS TREAT THE SHOTGUN AS IF IT WERE LOADED. (SEE POINTS 1, 2 AND 4 OF THE BASIC SAFETY RULES).**

### **CAUTION**

**It is advisable to carry out the stripping operations over a table to catch components should they drop.**

## BARREL REMOVAL

- Check that the carrier stop pin is pressed all the way down. If it is not, push it all the way down (fig. 9).
- Pull the breech bolt all the way back so that it remains open (fig. 10).
- Unscrew the front cap of the fore-end in an anticlockwise direction:

**fig. 29.1 shotgun with cross magazine tube (B-LOK)**

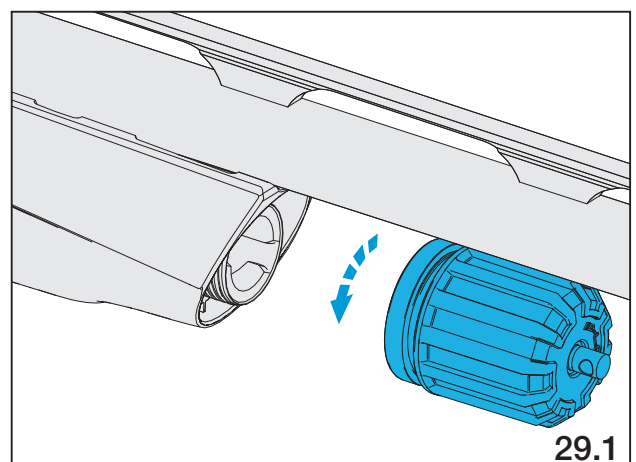
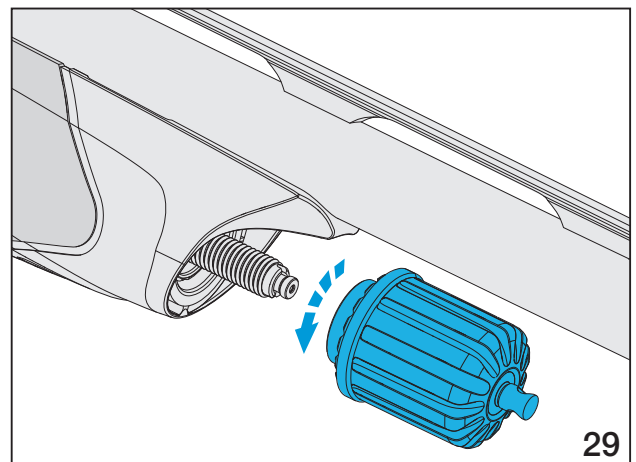

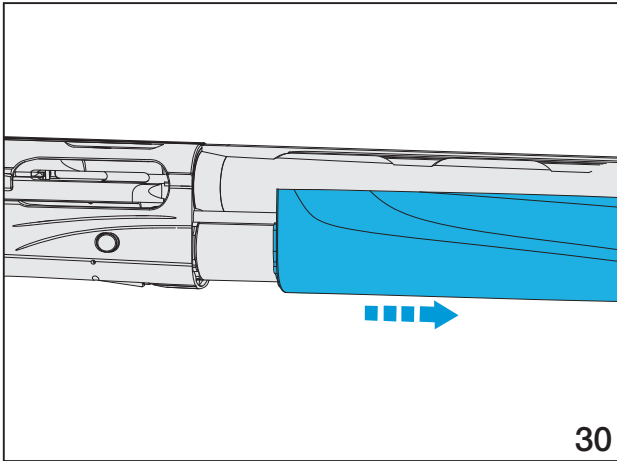

30

- Holding the shotgun by the barrel, pull the fore-end straight out toward the muzzle (fig. 30).
- Pull the barrel out of the stock-receiver assembly while holding the piston inside the gas cylinder:

fig. 31 shotgun A400

fig. 31.1 shotgun A300 OUTLANDER

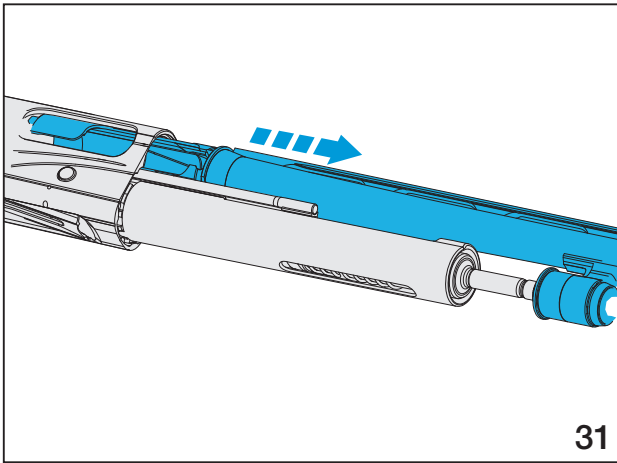

31

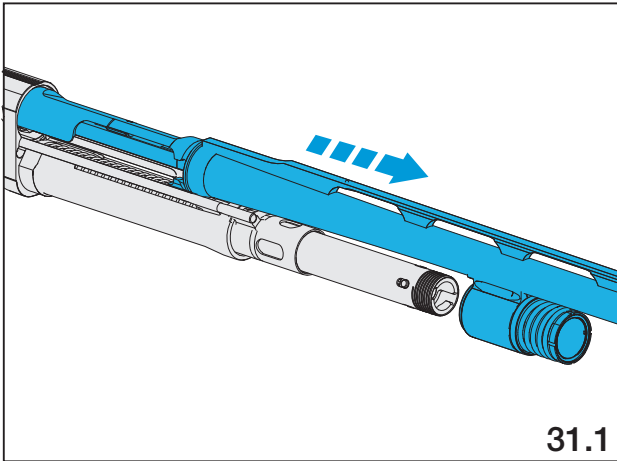

31.1

### CAUTION

**NEVER STRIP** the spring of the valve or the valve retaining nut (fig. 32). The valve device is self-cleaning and requires no maintenance. If necessary, contact a competent gunsmith.

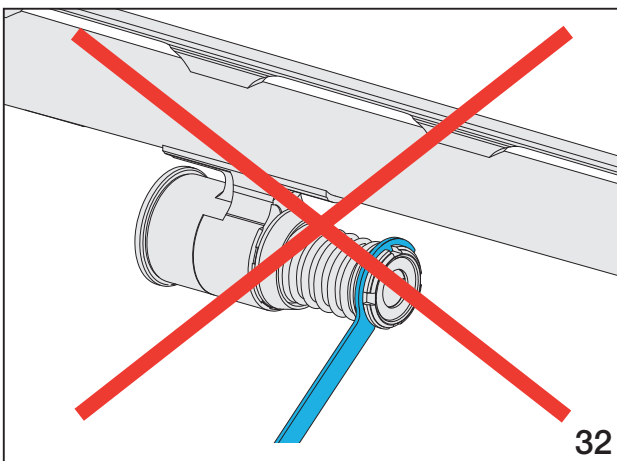

32

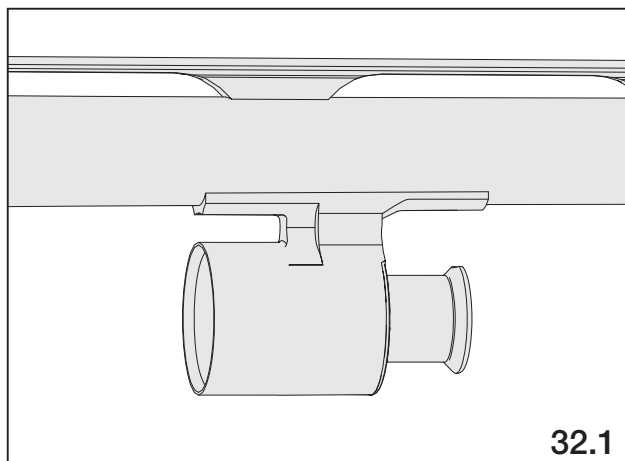

32.1

## BREECH BOLT STRIPPING

(Breech bolt, operating rods with sleeve, recoil spring, and piston stop).

### CAUTION

The breech bolt assembly needs only to be disassembled in order to clean its components.

- Keeping the index or middle finger of your left hand on the cocking handle, press the release button and allow the breech bolt to move forward slowly until it stops (fig. 33).
- Press the head of the breech bolt until the groove on its neck corresponds to the edge of the bolt body (fig. 34).
- Keeping the head depressed in this position, extract the cocking handle from the breech bolt, pulling forcefully (fig. 35).
- Working over a flat surface, with the ejection port pointed upwards, pull forward on the breech bolt assembly, the operating rods with sleeve, the recoil spring, and the spring holder, to force the breech bolt out from the receiver (fig. 36-37).

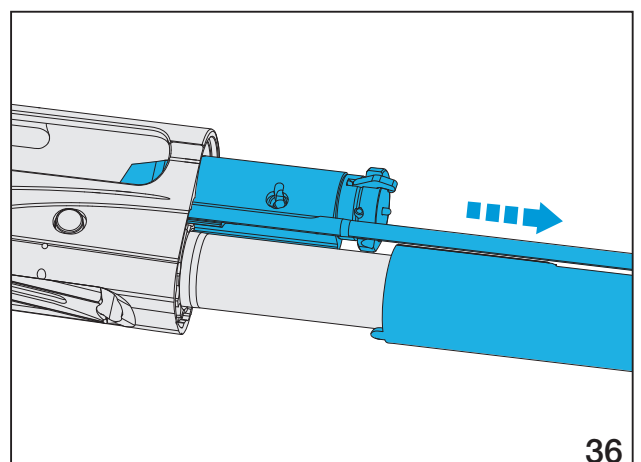
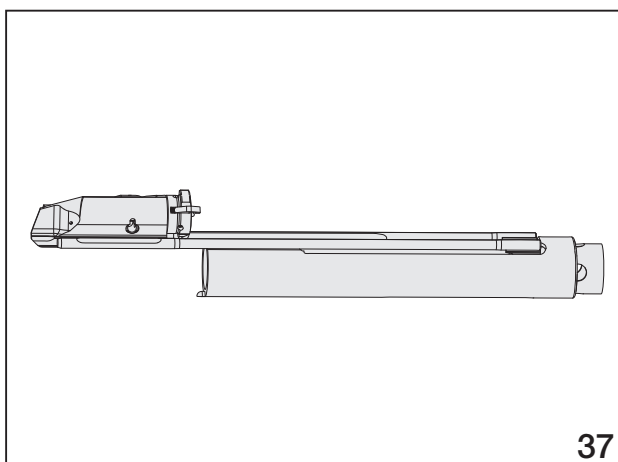
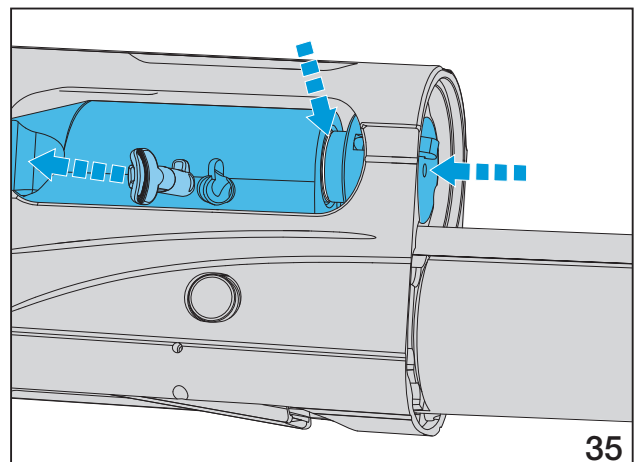
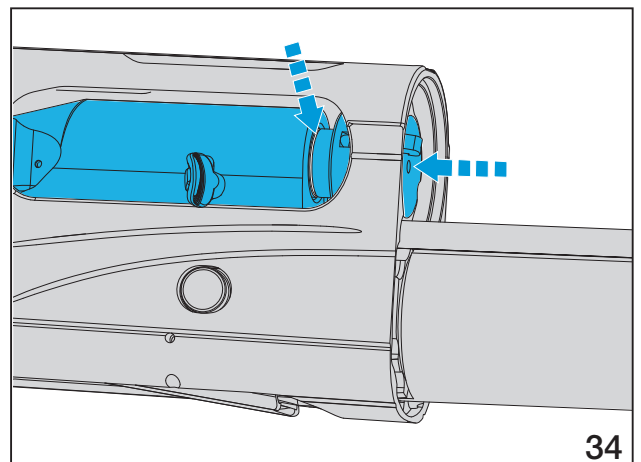
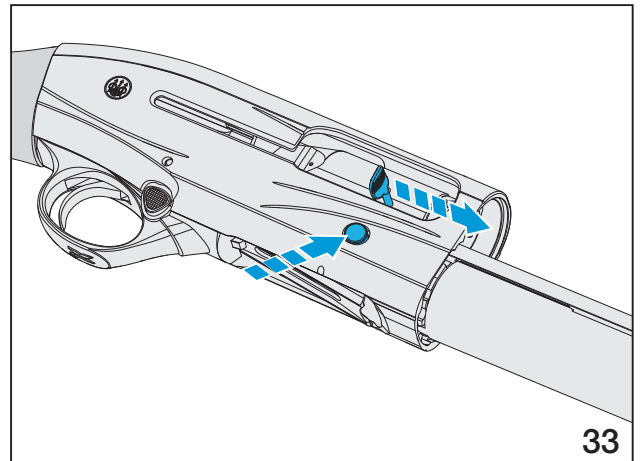

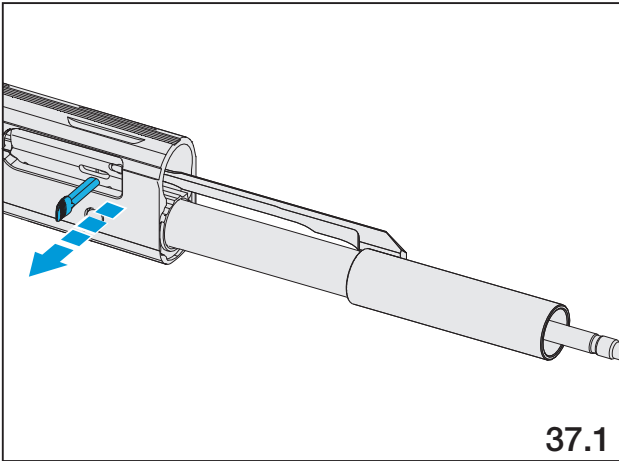

37.1

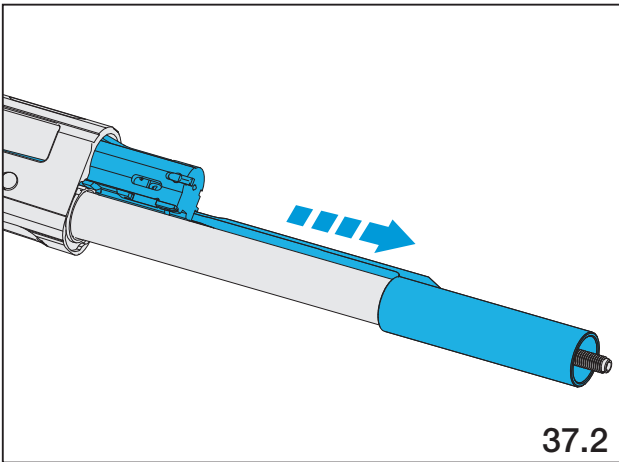

37.2

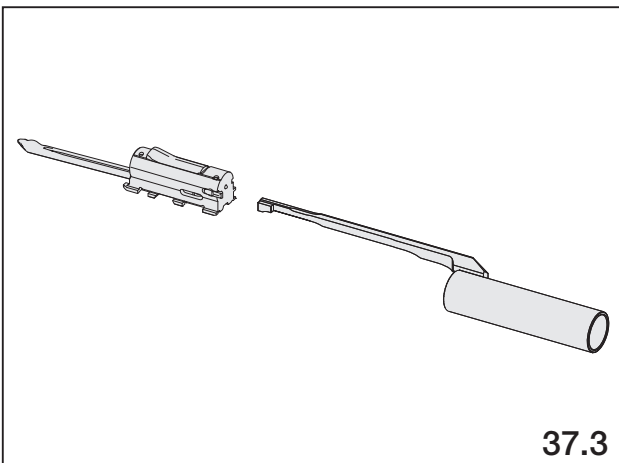

37.3

### A300 OUTLANDER ONLY

- Extract the cocking handle from the breech bolt, pulling forcefully (fig. 37.1).
- Over a flat surface, with the ejection port pointed upwards, slide the connecting rod with sleeve forward off the magazine tube shaft to extract the breech bolt assembly from the receiver (fig. 37.2).
- Separate the breech bolt assembly from the operating rod.
- The breech bolt is divided as follows (fig 37.3):
  - breech bolt with firing pin, locking block, extractor, springs and pins.
  - sleeve with connecting rod.

## TRIGGER PLATE REMOVAL

### CAUTION

The trigger plate only needs to be disassembled in order to clean the trigger mechanism.

- Engage the safety (the hammer is cocked) (fig. 20).
- Press the carrier stop pin, if it has not already been pressed (fig. 9).
- Remove the trigger guard retaining pin by pressing with a pin punch or an awl (fig. 38).
- Remove the trigger plate from the receiver, pressing on the trigger guard, first in the direction of the barrel, and then outwards (fig. 39).

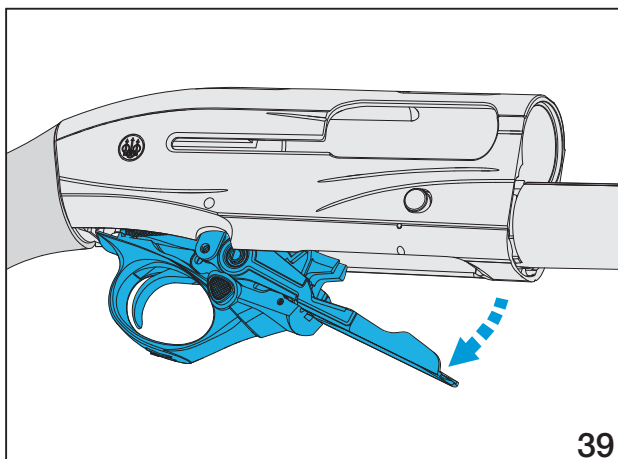
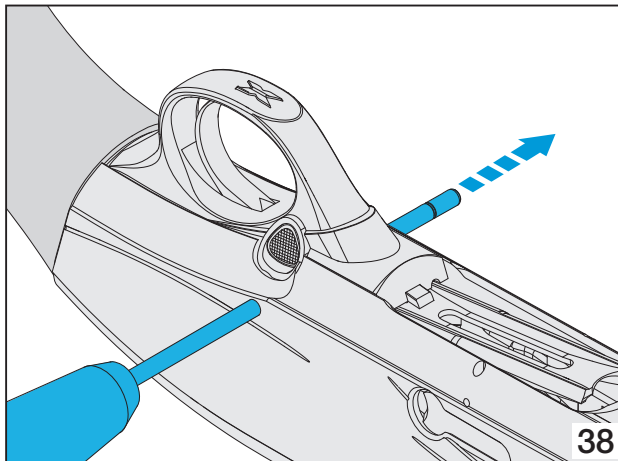

## ROUTINE MAINTENANCE

- Clean and lubricate your shotgun any time combustion residue, grease or dirt is deposited in any of the mechanisms. Cleaning and lubrication of the firearm after each use is the best way of ensuring that the components are protected against combustion corrosion or rusting from use in humid or salty environments.

At the end of a shooting day, carry out the Routine Maintenance as indicated below.

### WARNING

**ALWAYS CHECK THAT THE SHOTGUN IS UNLOADED (EMPTY CARTRIDGE CHAMBER, EMPTY RECEIVER, EMPTY MAGAZINE). INSPECT THE FIREARM BY LOOKING THROUGH THE EJECTION PORT, THE LOADING GATE AND THE CHAMBER. IF IT IS NOT EMPTY, UNLOAD IT AS INSTRUCTED IN THE RELEVANT SECTION. CHECK THAT THE HAMMER IS DECOCKED.**

### WARNING

**NEVER POINT THE FIREARM AT SOMEONE OR AT HARD, FLAT SURFACES. ALWAYS TREAT THE SHOTGUN AS IF IT WERE LOADED. (SEE POINTS 1, 2 AND 4 OF THE BASIC SAFETY RULES).**

### CAUTION

For Routine Maintenance, simply disassemble it following the procedures described in the relevant section.

## BARREL

- Carefully clean the inside of the barrel with a soft cloth (flannel) to remove any combustion residue. If necessary, use a bronze brush or a cloth soaked with Beretta Gun Oil.
- Thoroughly clean the locking shoulders on the barrel breech.
- Pull a soft, clean, dry cloth through the barrel.
- Lightly lubricate the barrel with a soft clean cloth soaked with Beretta Gun Oil.
- Check the barrel. The barrel and cartridge chamber must be clean and free from obstructions.

## WARNING

**EXCESS OIL OR GREASE OBSTRUCTING THE BARREL, EVEN PARTIALLY, IS VERY DANGEROUS WHEN FIRING AND MAY CAUSE DAMAGE TO THE SHOTGUN AND SERIOUS INJURY TO THE SHOOTER AND TO BYSTANDERS. NEVER SPRAY OR APPLY OIL TO THE CARTRIDGES. USE LUBRICANTS PROPERLY. YOU ARE RESPONSIBLE FOR THE PROPER CARE AND MAINTENANCE OF YOUR FIREARM.**

## GAS CYLINDER, PISTON, MAGAZINE TUBE

### CAUTION

**The use of Magnum and Super Magnum cartridges results in high combustion gas emissions. The particular composition of the powders of some Super Magnum ammunition can leave consistent deposits of combustion residue. The parts of the shotgun where this problem is most likely to arise are the gas cylinder, the piston and elastic piston seal and the magazine tube.**

- Carefully clean the piston, elastic piston seal and magazine tube and spray with Beretta Gun Oil.
- Ensure that the piston glides freely on the magazine tube.
- To clean the walls of the gas cylinder, spray them with Beretta Gun Oil and clean thoroughly with a bronze brush.
- After removing any combustion residue, clean the inside of the gas cylinder with a clean cloth.

### CAUTION

**The components specified above must not be lubricated.**

### CAUTION

**NEVER DISASSEMBLE the valve assembly (fig. 32). If necessary, contact a competent gunsmith.**



## SPECIAL MAINTENANCE

Depending on the conditions of use of the firearm, and at the end of the hunting season, Beretta recommends you carry out the following extraordinary maintenance operations in order to keep the shotgun in perfect working order.

### BREECH BOLT ASSEMBLY

- Spray the parts and clean with Beretta Gun Oil.
- Thoroughly dry with a soft cloth and lightly lubricate.

### TRIGGER PLATE

- Thoroughly clean the parts with a soft cloth.
- Lightly lubricate all the metal components and the trigger plate retaining pin.

### RECEIVER

- Proceed as indicated for the breech bolt. Clean thoroughly with a soft cloth and lubricate the internal breech bolt guides.

## WARNING

**DO NOT ATTEMPT TO CARRY OUT REPAIRS TO ANY FIREARM WITHOUT PROPER KNOWLEDGE OR TRAINING. DO NOT ALTER PARTS OR USE SUBSTITUTE PARTS NOT MANUFACTURED BY BERETTA. ANY ALTERATIONS OR ADJUSTMENTS THAT MAY BE NECESSARY TO THE OPERATING MECHANISM SHOULD BE PERFORMED BY THE MANUFACTURER OR BY ITS LOCAL AUTHORIZED DISTRIBUTOR.**

## REASSEMBLY

### WARNING

**ALWAYS CHECK THAT THE SHOTGUN IS UNLOADED (EMPTY CARTRIDGE CHAMBER, EMPTY RECEIVER, EMPTY MAGAZINE). INSPECT THE FIREARM BY LOOKING THROUGH THE EJECTION PORT, THE LOADING GATE AND THE CHAMBER. IF IT IS NOT EMPTY, UNLOAD IT AS INSTRUCTED IN THE RELEVANT SECTION.**

### WARNING

**NEVER POINT THE FIREARM AT SOMEONE OR AT HARD, FLAT SURFACES. ALWAYS TREAT THE SHOTGUN AS IF IT WERE LOADED. (SEE POINTS 1, 2 AND 4 OF THE BASIC SAFETY RULES).**

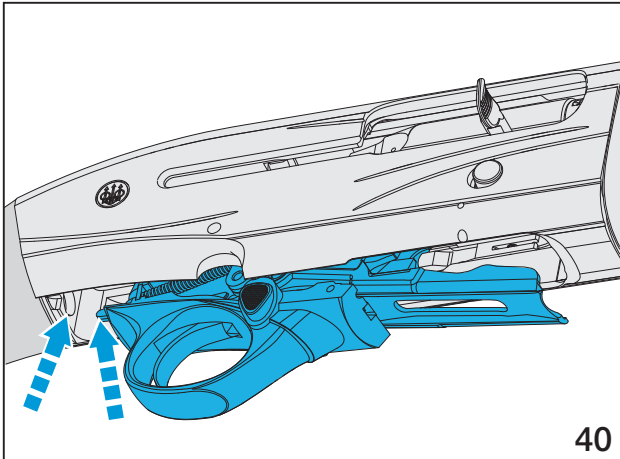

40

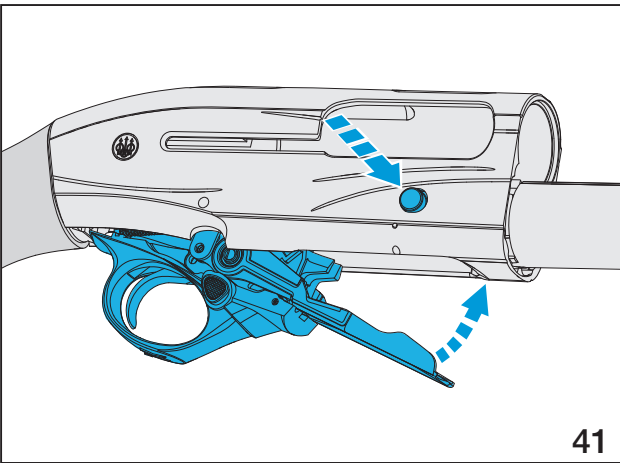

41

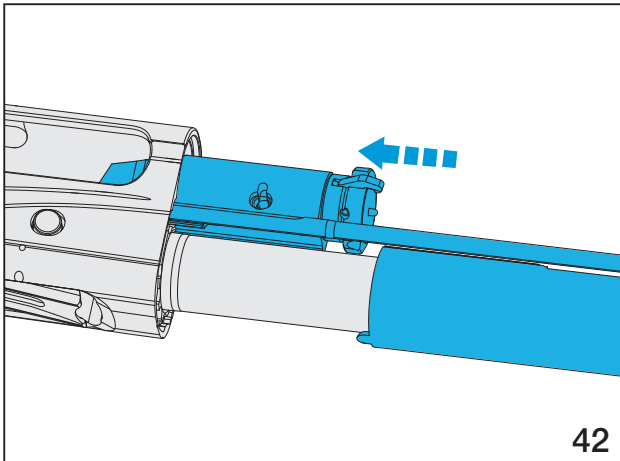

42

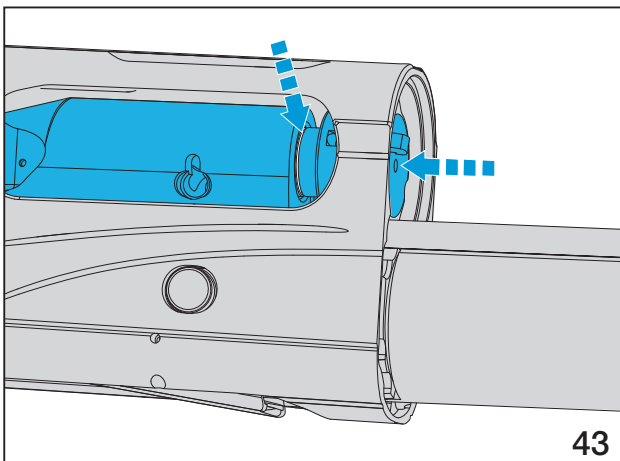

43

### TRIGGER PLATE REASSEMBLY

- Proceed in the reverse order to the disassembly, taking care that the hammer is cocked and the safety engaged.
- Make sure the rear part of the trigger plate is precisely adherent to the receiver and push it firmly in the direction of the stock (fig. 40).
- Hold the release button down firmly and turn the trigger plate until it is inserted into the receiver (fig. 41).
- Insert the trigger guard retaining pin only when the hole of the trigger guard is centered on the receiver.

### BREECH BOLT REASSEMBLY

- Working on a flat surface with the ejection port turned upwards, fit the breech bolt assembly, operating rods with sleeve, recoil spring and piston stop on the magazine tube (fig. 42).
- Push the operating rods with sleeve all the way in to insert the breech bolt into the receiver.
- Press the head of the breech bolt until the groove on its neck corresponds to the edge of the bolt body (fig. 43).

- Keeping the head pressed down in this position, insert the cocking handle on the breech bolt. Fasten it into position by hitting it firmly (fig. 44).

### A300 OUTLANDER ONLY

#### BREECH BOLT ASSEMBLY

- Refit the connecting rod with sleeve on the bolt.
- Insert the operating rod into the opening in the breech bolt assembly (fig. 44.1).
- Working on a flat surface with the ejection port turned upwards, fit the operating rod sleeve on the magazine tube (fig. 44.2).
- Push the breech bolt operating rod all the way in to insert the breech bolt into the receiver.
- Partially insert the breech bolt assembly into the receiver housing (fig. 44.3).
- Push the operating rod sleeve all the way in, past the recoil spring, until the breech bolt is in the unlocked position.
- Insert the cocking handle on the bolt (fig. 44.4).

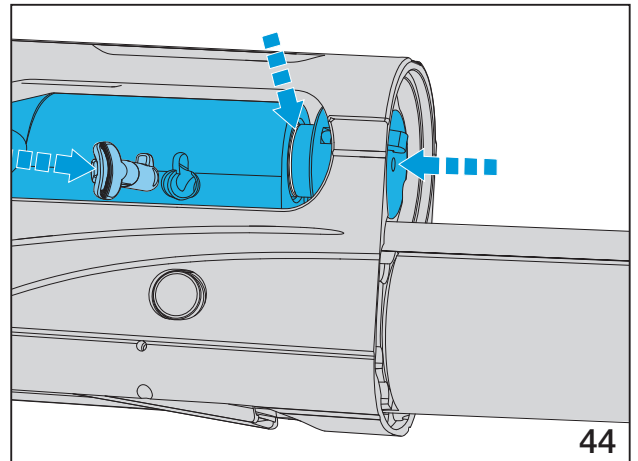

44

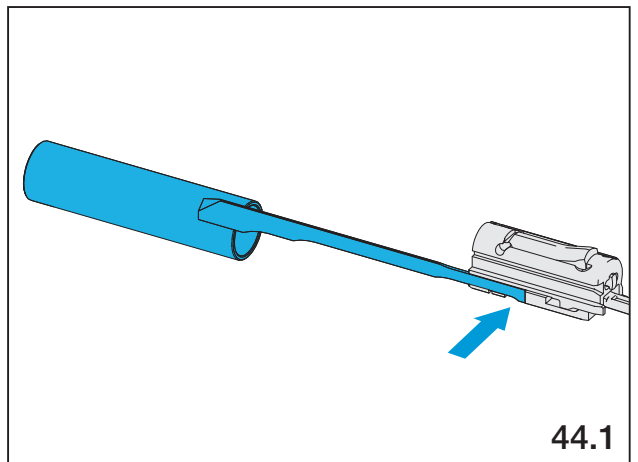

44.1

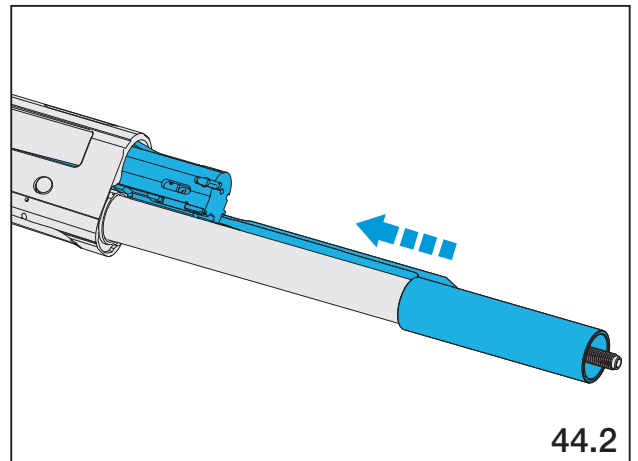

44.2

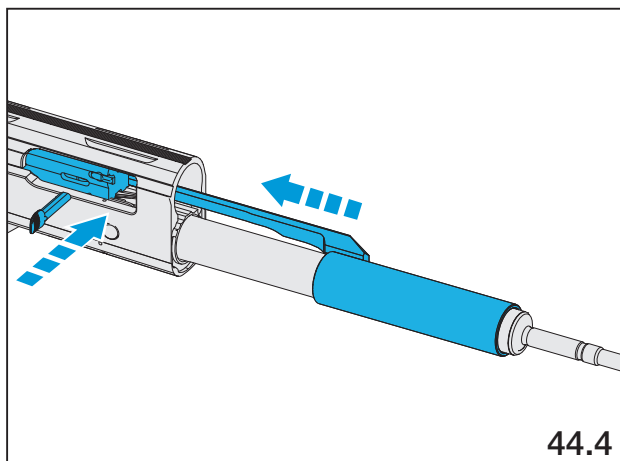

44.4

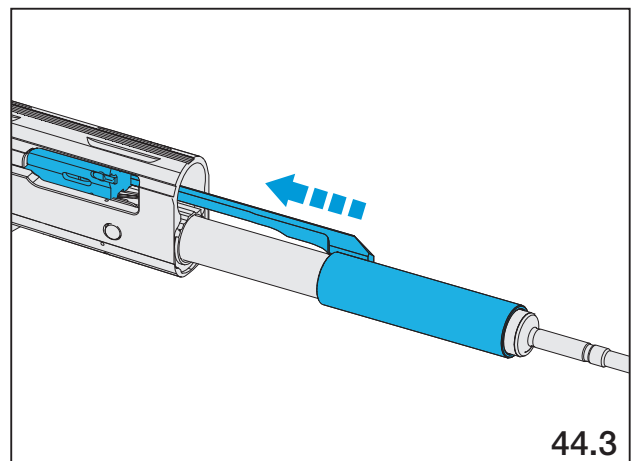

44.3

## BARREL REASSEMBLY

- Check the barrel. The barrel and cartridge chamber must be clean and free from obstructions.
- Insert the piston into the gas cylinder of the barrel, tightening the elastic seal with your fingers to make it easier to install the piston in the cylinder (fig. 8).
- Check that the carrier stop pin is pressed all the way down. If it is not, push it all the way down (fig. 9).
- Retract the breech bolt all the way so that it remains in the unlocked position (fig. 10).



### CAUTION

When the release button is pressed, the breech bolt is pushed forward by the recoil spring, until it is stopped at the ejection port by the cocking handle, with the likelihood of damage to both parts.

- Insert the barrel into the receiver (fig. 11), ensuring that the magazine tube cap shaft enters the piston hole as well as that of the gas cylinder and the valve assembly (fig. 12).
- Push the barrel all the way into the receiver until it stops.
- Slide the fore-end into place over the gas cylinder, checking for the correct centering on the receiver face (fig. 13). The fore-end is in the correct position when it is all the way up to the receiver face (fig. 14).
- Screw the fore-end cap on tightly (fig. 15).
- Keep your fingers away from the ejection port, press the breech bolt release button and gently guide the breech bolt to lock (fig. 16).



### CAUTION

When pressing the release button to close the breech bolt, be sure to not accidentally engage the cut-off lever. If this occurs, the breech bolt will be kept in the unlocked position by the cut-off lever. In this case, lock the breech bolt while disengaging the cut-off lever. Keep your fingers away from the ejection port (fig. 17).

- Keep the breech bolt pulled back 2 cm, pull the trigger, thereby decocking the hammer.



### WARNING

**ALWAYS STORE YOUR FIREARM SO THAT CHILDREN OR OTHER PERSONS NOT FAMILIAR WITH FIREARMS CANNOT GAIN ACCESS TO IT. TO REDUCE THE RISK OF ACCIDENTS INVOLVING CHILDREN, UNLOAD YOUR FIREARM AND LOCK IT AWAY. STORE THE AMMUNITION IN A SEPARATE LOCKED LOCATION. (SEE POINT 3 OF THE BASIC SAFETY RULES).**



### CAUTION

If the firearm will not be used for a long time, keep it lubricated and disassembled (see the chapters “Maintenance” on page 37/39 and “Storage” on page 67).

## ACCESSORIES AND ADJUSTMENTS

The accessories and relevant adjustments described below may concern just some models in the range of shotguns described in this Manual, and therefore, may differ from your shotgun and accessories.

### CHECKING THE CONDITION OF THE CHOKE TUBES

- Always check the appearance and cleaning of the choke tubes before using the shotgun.
- Check correct tightness in the barrel with the spanner provided.
- Never use choke tubes that show signs of defects, warping or incrustation.
- Make sure that the choke tube inserted is appropriate for the intended use and shot type to be used (steel or lead).

## BERETTA OPTIMACHOKE® HP CHOKE TUBES (Models A400, A350 and 1301 only)

Beretta Optimachoke® HP (High Performance) tubes are built in high resistance steel to ensure a long life and rust protection and are designed to withstand the use of steel shot. They can also shoot High Performance steel shots.

### WARNING

**THE OPTIMA-BORE® HP BARREL ON MODEL A400 CAN ONLY FIT OPTIMACHOKE® HP CHOKE TUBES. OTHER TYPES OF BERETTA INTERCHANGEABLE CHOKE TUBES ARE INCOMPATIBLE WITH OPTIMA-BORE® HP BARRELS. YOUR SHOTGUN WILL BE DAMAGED IF YOU FIRE IT USING THE INCORRECT CHOKE DESIGN.**

Beretta markings	American name	Compatibility of choke tubes with steel shot	Notches on rim
0 (*)	F (full)	SP (Steel Proof) <sup>1</sup>	I
00 (**)	IM (Improved Modified)	SP (Steel Proof) <sup>1</sup>	II
000 (***)	M (Modified)	SP (Steel Proof)	III
0000 (****)	IC (Improved Cylinder)	SP (Steel Proof)	IIII
C0000 (C****)	CL (Cylinder)	SP (Steel Proof)	IIII

(1) Not recommended for steel shot.

Optimachoke® is a registered trademark of Fabbrica d'Armi Pietro Beretta S.p.A.

## BERETTA MOBILCHOKE® CHOKE TUBES (MODEL A300 ONLY)

Beretta Mobilchoke® tubes are built in high resistance steel to ensure a long life and rust protection and are designed to withstand the use of steel shot. They can also shoot High Performance steel shots.

### **WARNING**

**THE BARREL OF THE MODEL A300 OUTLANDER CAN ONLY FIT MOBILCHOKE® TUBES. ON MOBILCHOKE® BARRELS, THE OTHER TYPES OF BERETTA INTERCHANGEABLE CHOKE TUBES ARE INCOMPATIBLE. YOUR SHOTGUN WILL BE DAMAGED IF YOU FIRE IT USING THE INCORRECT CHOKE DESIGN.**

Beretta markings	American name	Compatibility of choke tubes with steel shot	Notches on rim
0 (*)	F (full)	SP (Steel Proof) <sup>1</sup>	I
00 (**)	IM (Improved Modified)	SP (Steel Proof) <sup>1</sup>	II
000 (***)	M (Modified)	SP (Steel Proof)	III
0000 (****)	IC (Improved Cylinder)	SP (Steel Proof)	IIII
C0000 (C****)	CL (Cylinder)	SP (Steel Proof)	IIII

(1) Not recommended for steel shot.  
Mobilchoke® is a registered trademark of Fabbrica d'Armi Pietro Beretta S.p.A.

## CHOKE TUBE REMOVAL

### **WARNING**

ALWAYS CHECK THAT THE SHOTGUN IS UNLOADED (EMPTY CARTRIDGE CHAMBER, EMPTY RECEIVER, EMPTY MAGAZINE). INSPECT THE FIREARM BY LOOKING THROUGH THE EJECTION PORT, THE LOADING GATE AND THE CHAMBER. IF IT IS NOT EMPTY, UNLOAD IT AS INSTRUCTED IN THE RELEVANT SECTION.

### **WARNING**

NEVER LOOK DIRECTLY THROUGH THE BARREL FROM THE MUZZLE AND DO NOT REPLACE THE CHOKE WITH THE SHOTGUN LOADED, EVEN WITH THE SAFETY ENGAGED.

### **WARNING**

THE SAFETY CAN ONLY BE INSERTED WITH THE HAMMER COCKED. THE HAMMER IS COCKED BY PULLING BACK THE BREECH BOLT. WHEN THE SAFETY BUTTON SHOWS THE RED RING THE SAFETY IS DISENGAGED, SO THE FIREARM IS READY FOR USE. WHEN THE RED RING IS NOT VISIBLE ON THE SAFETY BUTTON, THE SAFETY IS ENGAGED.

- Unscrew the choke, turning it anticlockwise, using the wrench provided, and take it out from the barrel muzzle. (fig. 45).

## CLEANING THE CHOKE TUBE AND ITS HOUSING

### **WARNING**

ALWAYS CHECK THAT THE SHOTGUN IS UNLOADED (EMPTY CARTRIDGE CHAMBER, EMPTY RECEIVER, EMPTY MAGAZINE). INSPECT THE FIREARM BY LOOKING THROUGH THE EJECTION PORT, THE LOADING GATE AND THE CHAMBER. IF IT IS NOT EMPTY, UNLOAD IT AS INSTRUCTED IN THE RELEVANT SECTION. CHECK THAT THE HAMMER IS DECOCKED.

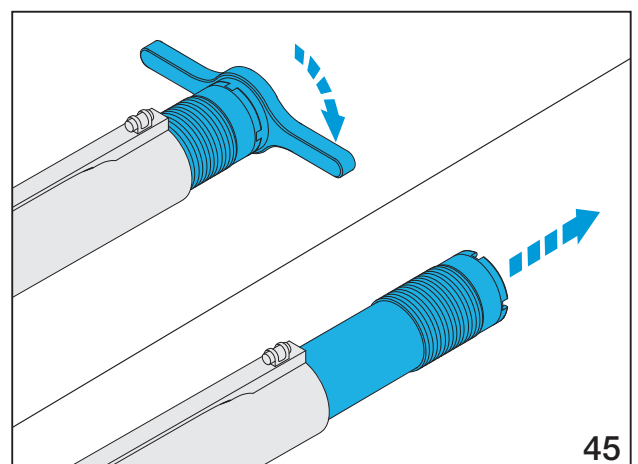

## **! WARNING**

**NEVER LOOK DIRECTLY THROUGH THE BARREL FROM THE MUZZLE AND DO NOT REPLACE THE CHOKE WITH THE SHOTGUN LOADED, EVEN WITH THE SAFETY ENGAGED.**

- Clean the choke housing thoroughly using, if necessary, a brush swab soaked with Beretta Gun Oil. Dry with a soft cloth.
- Check that the choke is perfectly clean inside and outside.
- Apply a thin film of Beretta Gun Oil on the barrel thread and choke tube.

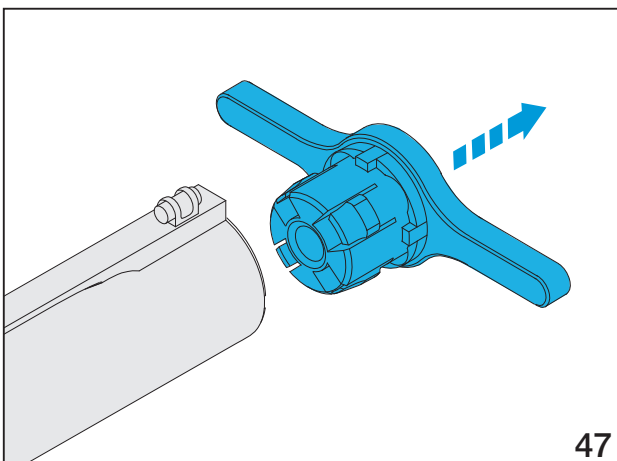
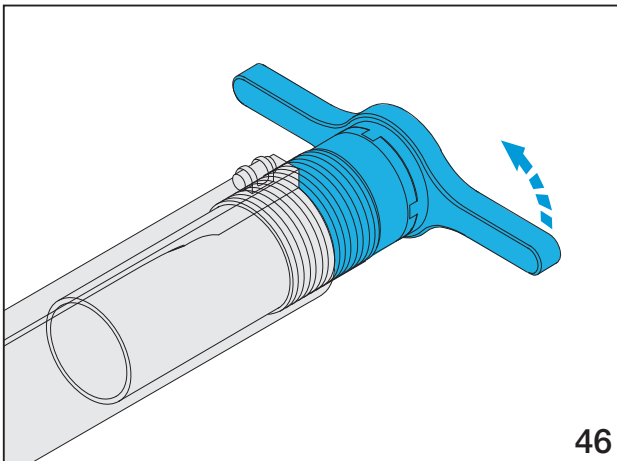

## CHOKE TUBE INSERTION

### **! WARNING**

**ALWAYS CHECK THAT THE SHOTGUN IS UNLOADED (EMPTY CARTRIDGE CHAMBER, EMPTY RECEIVER, EMPTY MAGAZINE). INSPECT THE FIREARM BY LOOKING THROUGH THE EJECTION PORT, THE LOADING GATE AND THE CHAMBER. IF IT IS NOT EMPTY, UNLOAD IT AS INSTRUCTED IN THE RELEVANT SECTION. CHECK THAT THE HAMMER IS DECOCKED.**

### **! WARNING**

**NEVER LOOK DIRECTLY THROUGH THE BARREL FROM THE MUZZLE AND DO NOT REPLACE THE CHOKE WITH THE SHOTGUN LOADED, EVEN WITH THE SAFETY ENGAGED.**

### **! WARNING**

**CHECK THAT THE CHOKE TUBE IS IN PRISTINE CONDITION (NOT DAMAGED) PRIOR TO INSTALLING IT.**

- Make sure that the barrel thread and choke tube are perfectly clean and lightly oiled.
- Install the desired choke tube.
- Manually screw the choke tube clockwise into the barrel. Use the Beretta wrench provided to tighten the choke tube until it is fully lowered into its seat in the barrel. Forcefully tighten it manually (fig. 46).
- Remove the wrench from barrel (fig. 47).



 **WARNING**

PERIODICALLY CHECK THAT THE CHOKE TUBE IS TIGHTENED CORRECTLY, ENSURING THAT THE SHOTGUN IS UNLOADED (EMPTY CARTRIDGE CHAMBER, EMPTY RECEIVER AND EMPTY MAGAZINE) AND BREECH BOLT IN THE UNLOCKED POSITION. IF NECESSARY, FIRMLY TIGHTEN THE CHOKE TUBE WITH THE BERETTA SPANNER. CORRECT TIGHTENING OF THE CHOKE TUBE WILL AVOID THE OCCURRENCE OF SHOTGUN DAMAGE OR INJURY.

 **WARNING**

THE CHOKE MUST BE KEPT CORRECTLY TIGHTENED IN THE BARREL AT ALL TIMES, EVEN DURING STORAGE AND CLEANING. CLEANING THE BARREL WITHOUT THE CHOKE TUBE INSTALLED MAY LEAD TO DIRT BECOMING LODGED IN THE BARREL THREAD AND PREVENTING THE CHOKE TUBE FROM SCREWING IN PROPERLY, OR TO THE FORMATION OF RUST OR OBSTRUCTION IN THE BARREL.

 **WARNING**

NEVER SHOOT THE CHOKE BARREL WITHOUT INSERTING A CHOKE TUBE. SHOOTING WITHOUT A CHOKE TUBE IN THE BARREL IS VERY DANGEROUS, AS RESIDUES OF LEAD OR DEBRIS MAY BECOME LODGED IN THE THREAD CREATING AN OBSTRUCTION WITHIN THE BARREL. ALSO, NOT USING A CHOKE TUBE WILL DAMAGE THE THREADING OF THE BARREL IRREPARABLY AND RESULT IN IRREGULAR SHOT SPREAD.

DO NOT ALTER OR MODIFY AN EXISTING FIXED CHOKE BERETTA BARREL FOR THE USE OF INTERCHANGEABLE CHOKE TUBES. THE BARREL WALL THICKNESS WOULD BE TOO THIN TO SAFELY CONTAIN THE PRESSURE LEVELS GENERATED BY SHOOTING.

**CHOKE TUBE IDENTIFICATION - FIG. 48 + TABLE**

<b>Fixed chokes and Beretta chokes</b>			
<b>Beretta markings</b>	<b>American name</b>	<b>Notches on rim</b>	<b>Steel shot compatibility</b>
0 (*)	F (full)	I	No
00 (**)	IM (Improved Modified)	II	No
000 (***)	M (Modified)	III	Yes
0000 (****)	IC (Improved Cylinder)	IIII	Yes
C0000 (C****)	CL-C (Cylinder)	IIIII	Yes
S	SK USA	without	Yes
SK (Skeet Beretta) (1)	SK (Skeet)	without	Yes
without	XF (Extra Full)	without	No
without	LF (Light Full)	without	No
without	LM (Light Modified)	without	Yes
(1) Beretta skeet special choke tube with negative value.			

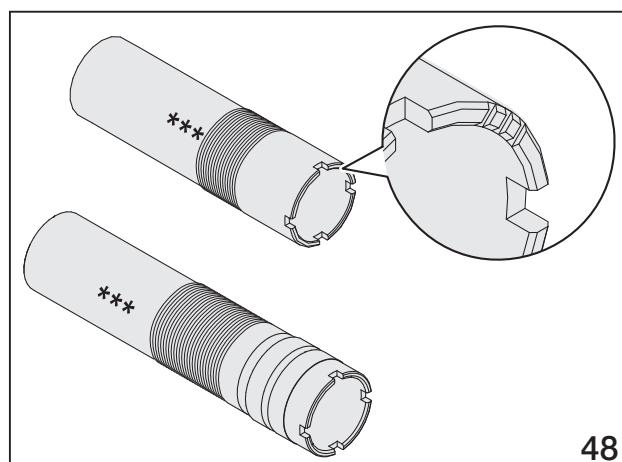

# STOCK DROP AND CAST MODIFICATION

## **WARNING**

**ALWAYS CHECK THAT THE SHOTGUN IS UNLOADED (EMPTY CARTRIDGE CHAMBER, EMPTY RECEIVER, EMPTY MAGAZINE). INSPECT THE FIREARM BY LOOKING THROUGH THE EJECTION PORT, THE LOADING GATE AND THE CHAMBER. IF IT IS NOT EMPTY, UNLOAD IT AS INSTRUCTED IN THE RELEVANT SECTION.**

## **WARNING**

**NEVER POINT THE FIREARM AT SOMEONE OR AT HARD, FLAT SURFACES. ALWAYS TREAT THE SHOTGUN AS IF IT WERE LOADED. (SEE POINTS 1, 2 AND 4 OF THE BASIC SAFETY RULES).**

The shotgun is equipped with a system to modify the drop or cast of the stock, and it consists of two spacers:

- 1) Front spacer made of polymer
- 2) Rear spacer made of steel.

When the spacers are fitted to the firearm, it is possible to configure the drop and cast of the stock as follows:

- Right drop 60 mm C-60-DX
- Right drop 55 mm C-55-DX
- Left drop 60 mm C-60-SX
- Left drop 55 mm C-55-SX

The firearm is also supplied with another set of spacers to configure the stock drop and cast as follows:

- Right drop 65 mm C-65-DX
- Right drop 50 mm C-50-DX
- Left drop 65 mm C-65-SX
- Left drop 50 mm C-50-SX

The figure shows the possible combinations of ways to position the spacers supplied.

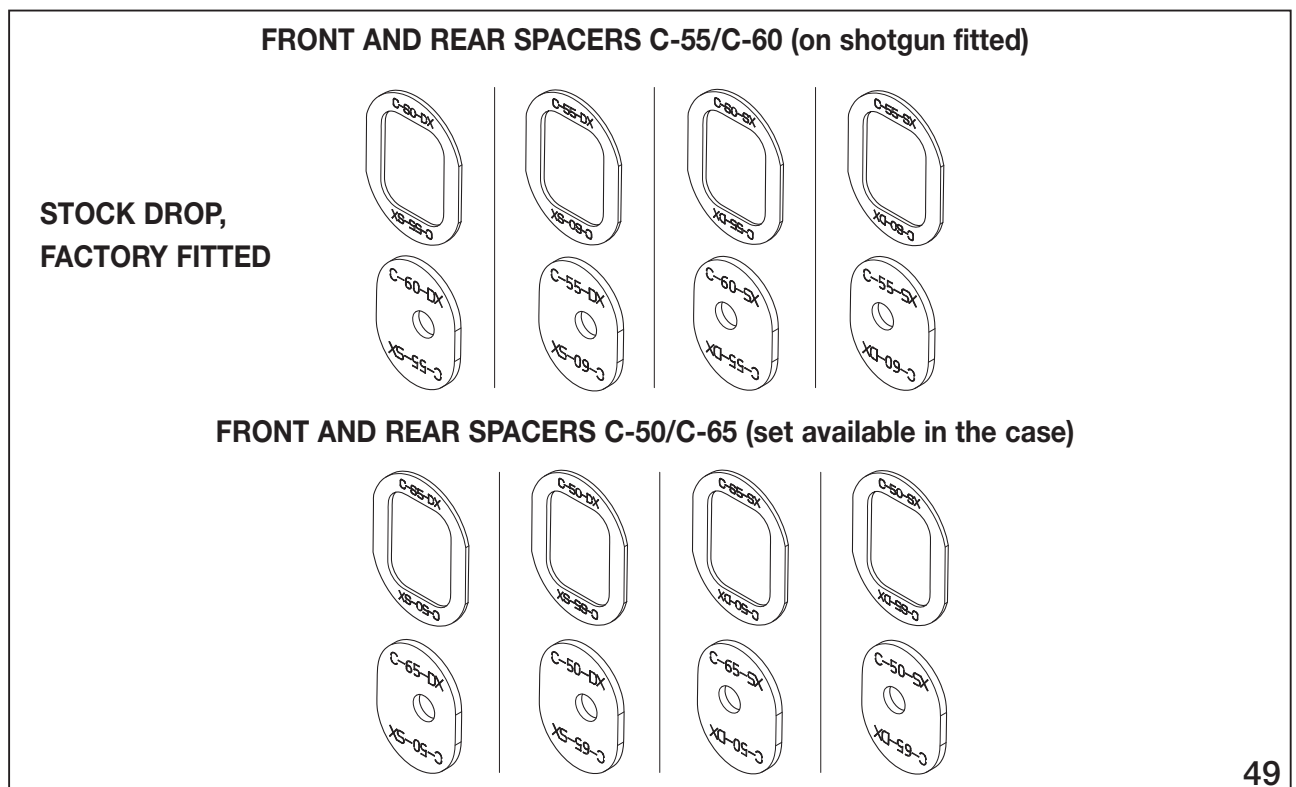

**TO CHANGE THE DROP IN ONE OF THE EIGHT POSSIBLE CONFIGURATIONS, PROCEED AS FOLLOWS.**

 **Notice**

The right-hand drop is shown with the letters DX, while the left-hand dropped is shown with the letters SX.

The drop value is shown with the numbers 50, 55, 60, 65.

Drop and cast values must be the same for both spacers, as shown in figure 49.

**REQUIRED TOOLS**

- 1 Philips and 1 flat-head screwdriver
- Torx T10 and T15 screwdriver
- 1 Hexagonal spanner, 6 mm
- 1 Tube spanner, 13 mm
- Torque wrench with a 13-mm pipe extension recommended. Tightness torque 9-11 N/m

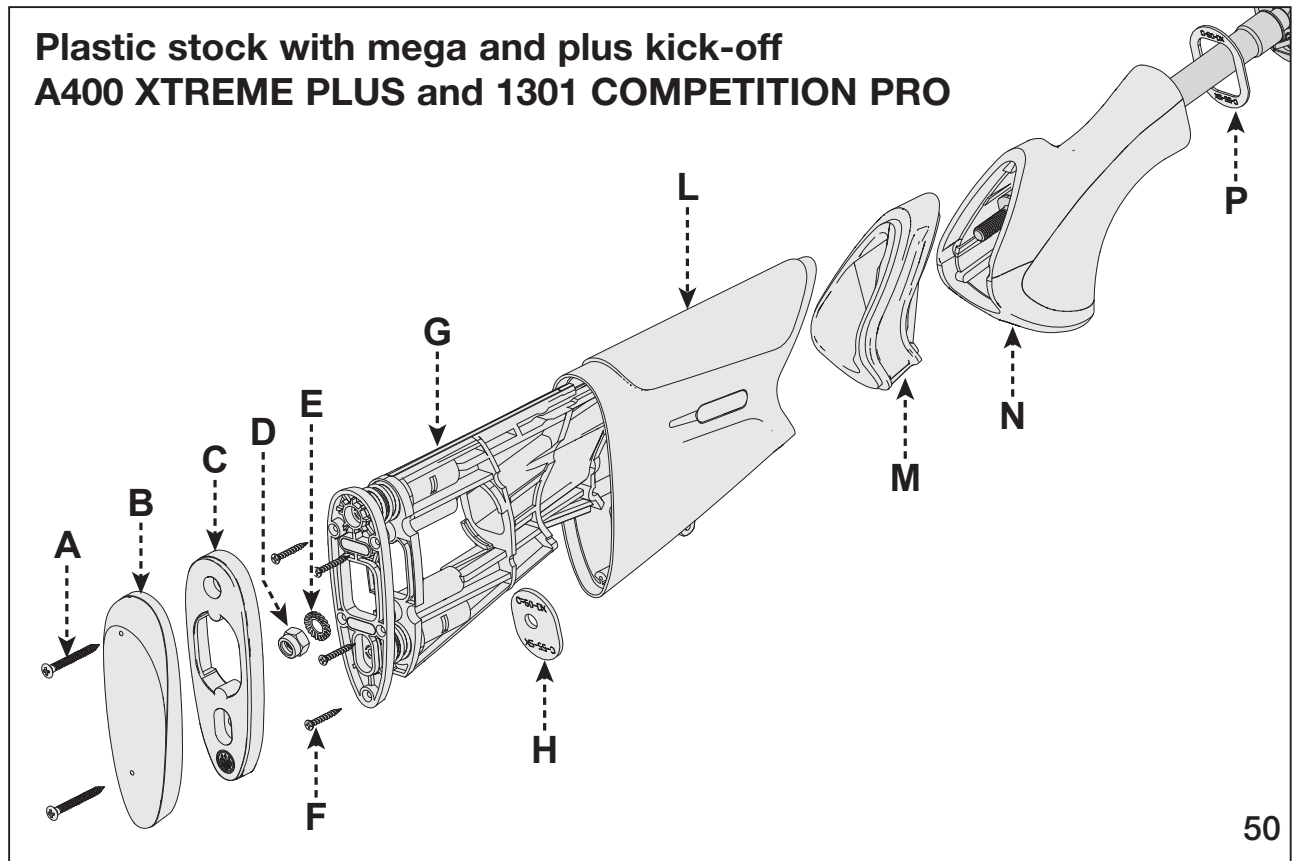

## STRIPPING

- Use the Phillips screwdriver to remove the two screws (A) sunk into the recoil pad.
- Remove the recoil pad (B) and shim (C), which covers the kick-off.
- Use the 13-mm tube spanner to completely unscrew the retaining nut of the stock and remove the nut (D) and spring washer (E) inside.

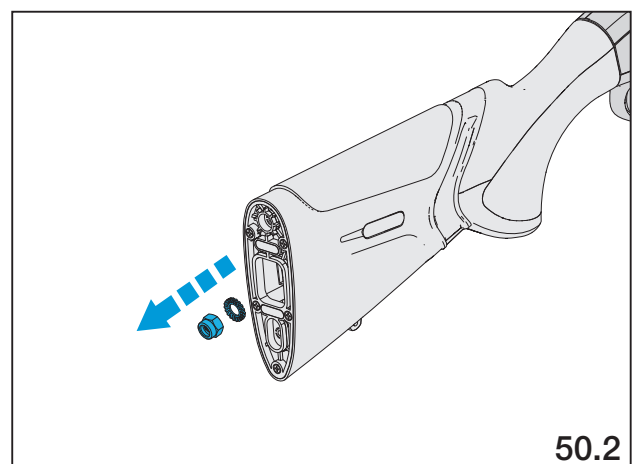
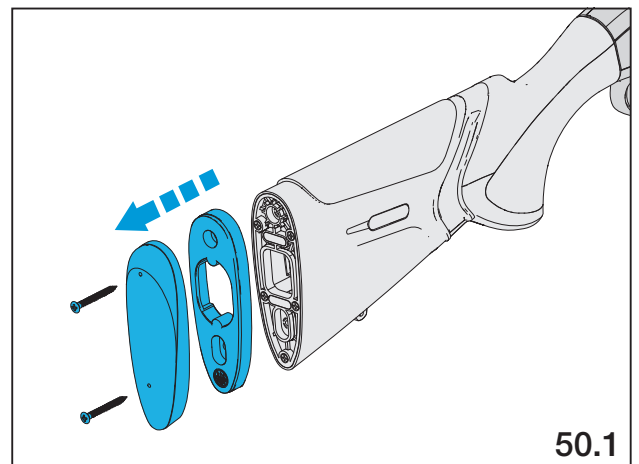

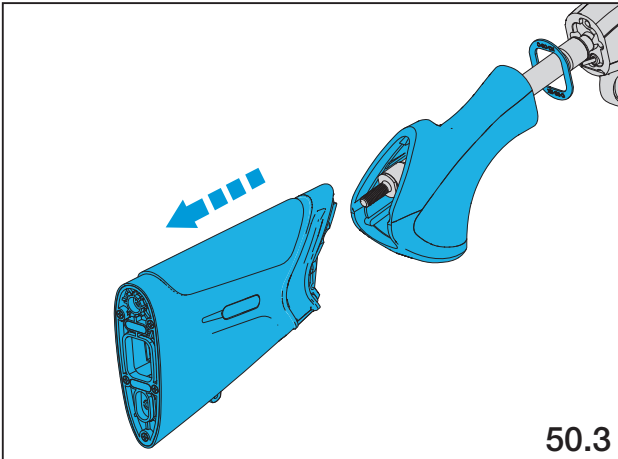

50.3

- Separate the stock (L) and remove the front plate (P) and handgrip (N).
- Use the T10 torx screwdriver to remove the 5 screws (F) connecting the kick-off to the surface of the stock.
- Remove the rubber seal (M), sliding it out from the front.
- Push the kick-off (G) out from the stock surface (L).
- Remove the spacer (H), turning it until it comes free of its seat.

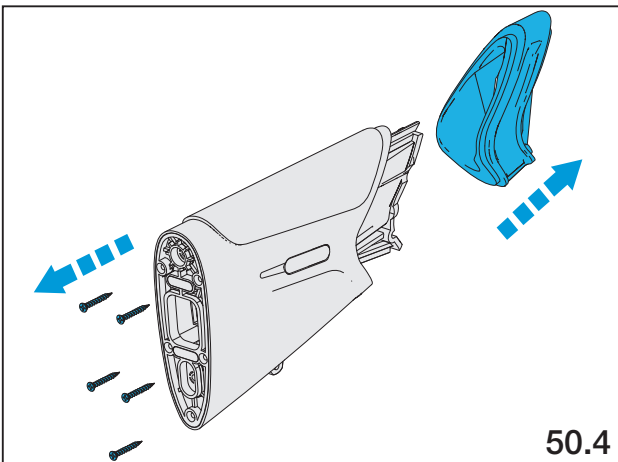

50.4

## REASSEMBLY

- Carry out the above procedures in reverse order.

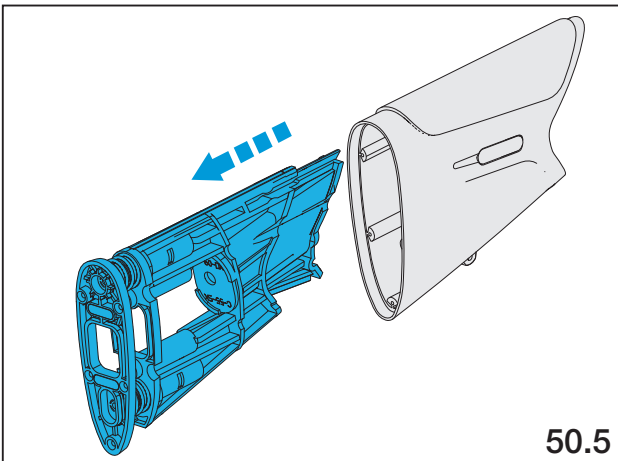

50.5

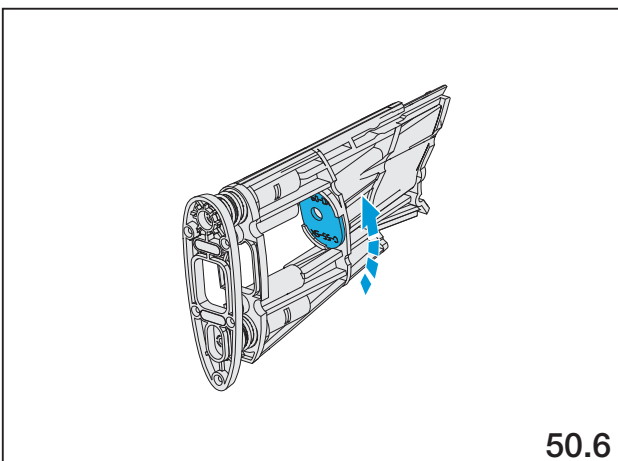

50.6

### Wooden stock with kick-off A400 UPLAND and A300 WOOD

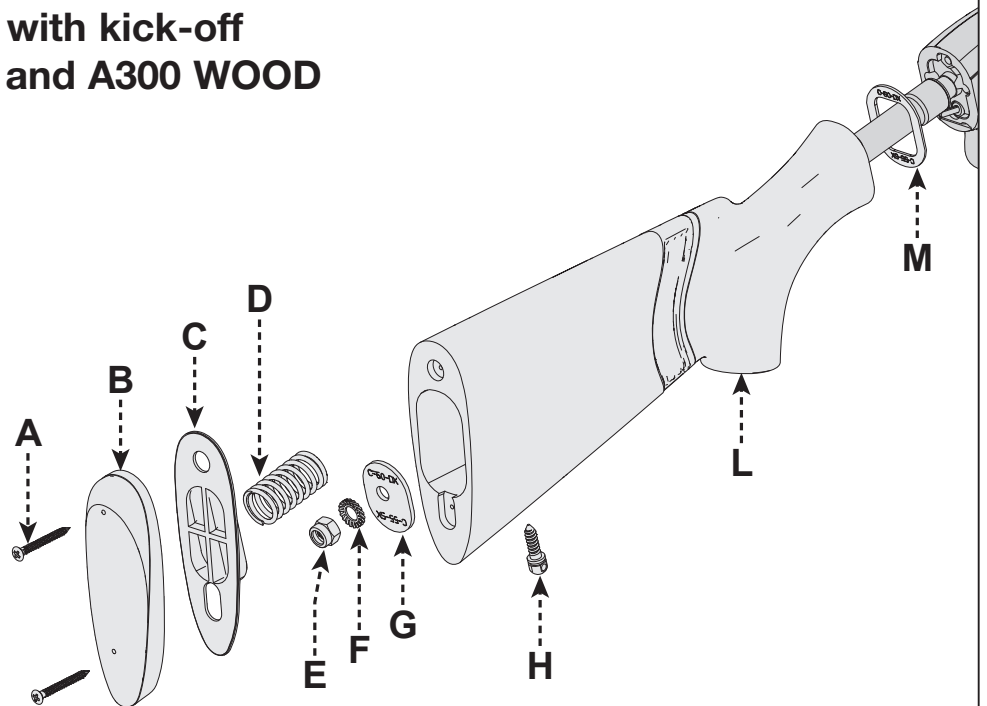

51

### STRIPPING

- Use the Phillips screwdriver to remove the two screws (A) sunk into the recoil pad.
- Remove the recoil pad (B) and shim (C), which covers the kick-off and the recoil spring (D).

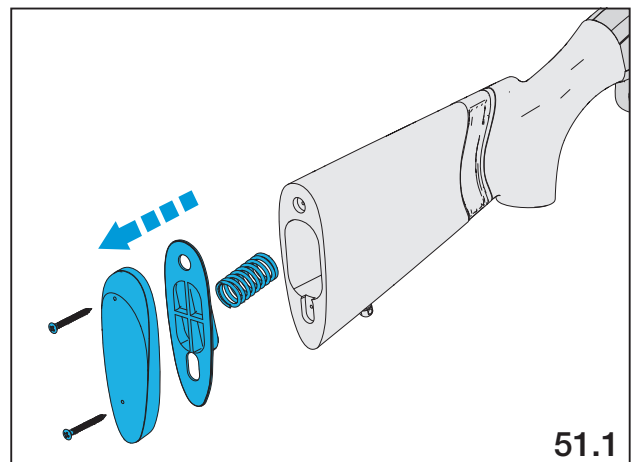

51.1

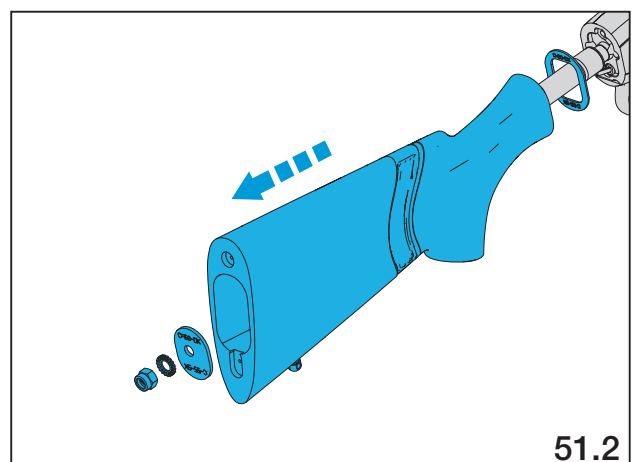

51.2

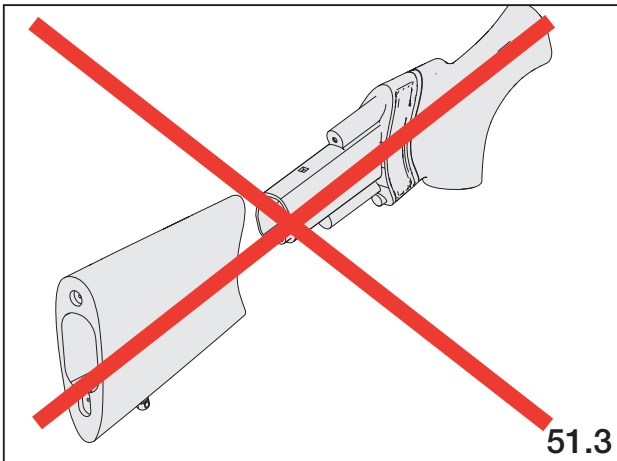

- Use the 13-mm tube wrench to completely unscrew the retaining nut of the stock and remove the inside nut (E) and the inside spring washer (F).
- Separate the stock (L) from the receiver and remove the front spacer (M) and the rear one (G) from the seat inside the stock.
- **Take care not to separate the two parts of the stock (fig. 51.3).**

### REASSEMBLY

- Carry out the above procedures in reverse order.



## Wooden stock with kick-off A400 XPLOR and A400 XCELL

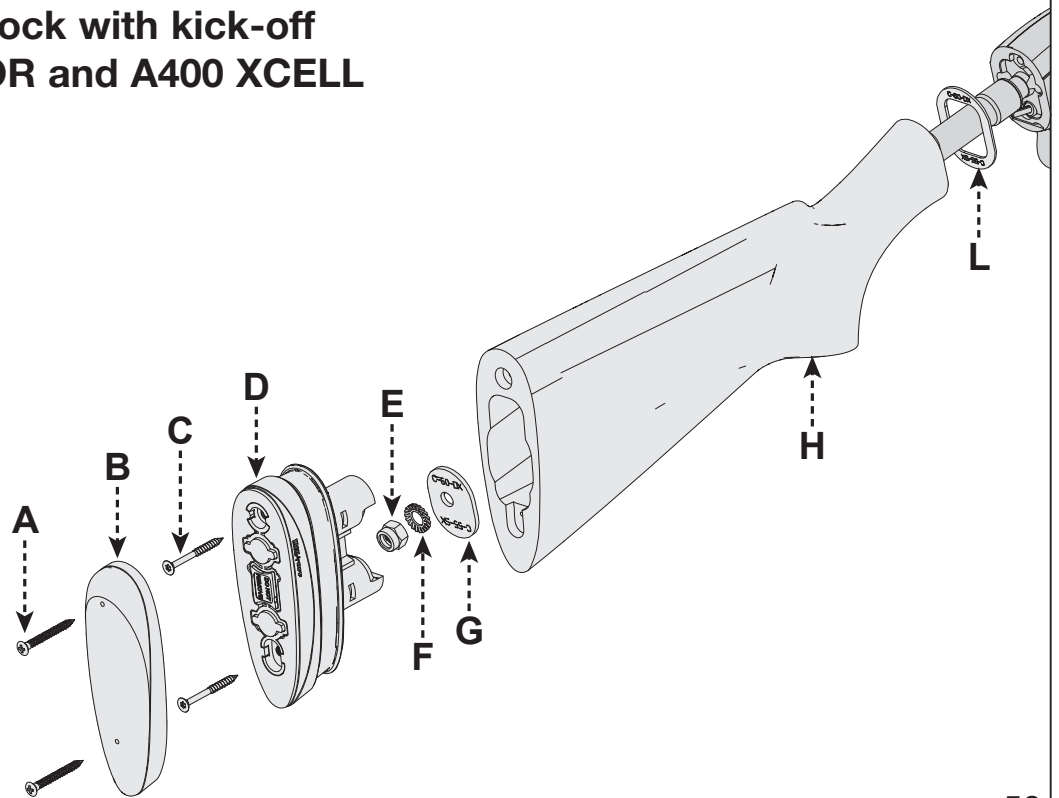

52

### STRIPPING

- Use the Phillips screwdriver to remove the two screws (A) sunk into the recoil pad.
- Remove the recoil pad (B).
- Use the T15 torx screwdriver to remove the 2 screws (C) connecting the kick-off to the surface of the stock.

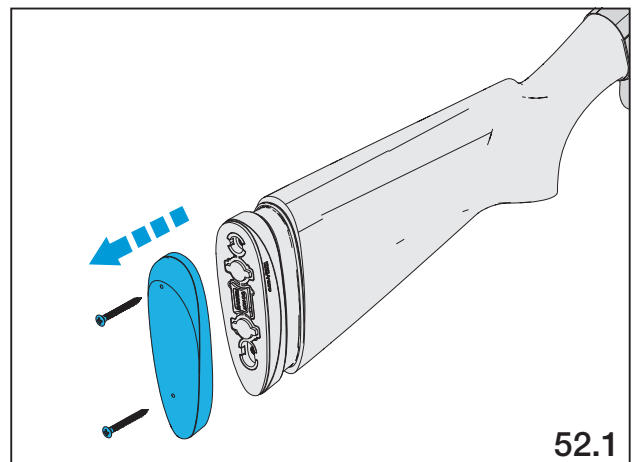

52.1

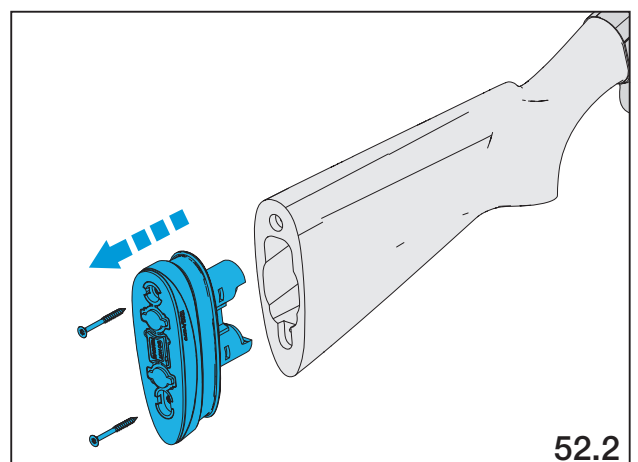

52.2

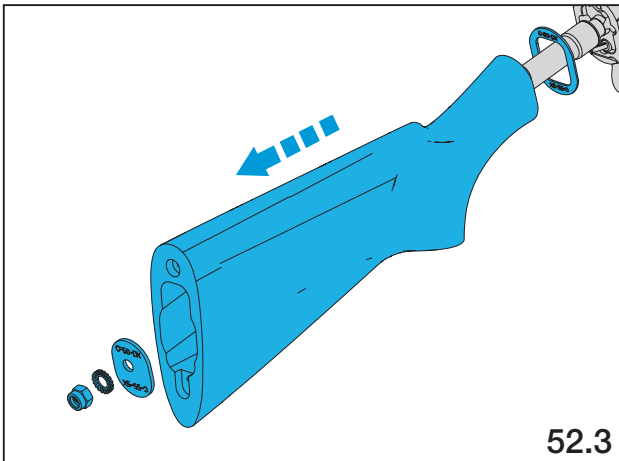

- Use the 13-mm tube wrench to completely unscrew the retaining nut of the stock and remove the inside nut (E) and the inside spring washer (F).
- Separate the stock (H) from the receiver and remove the front spacer (L) and the rear one (G) from the seat inside the stock.

### REASSEMBLY

- Carry out the above procedures in reverse order.

## Plastic stock with kick-off A350 and 1301 TACTICAL

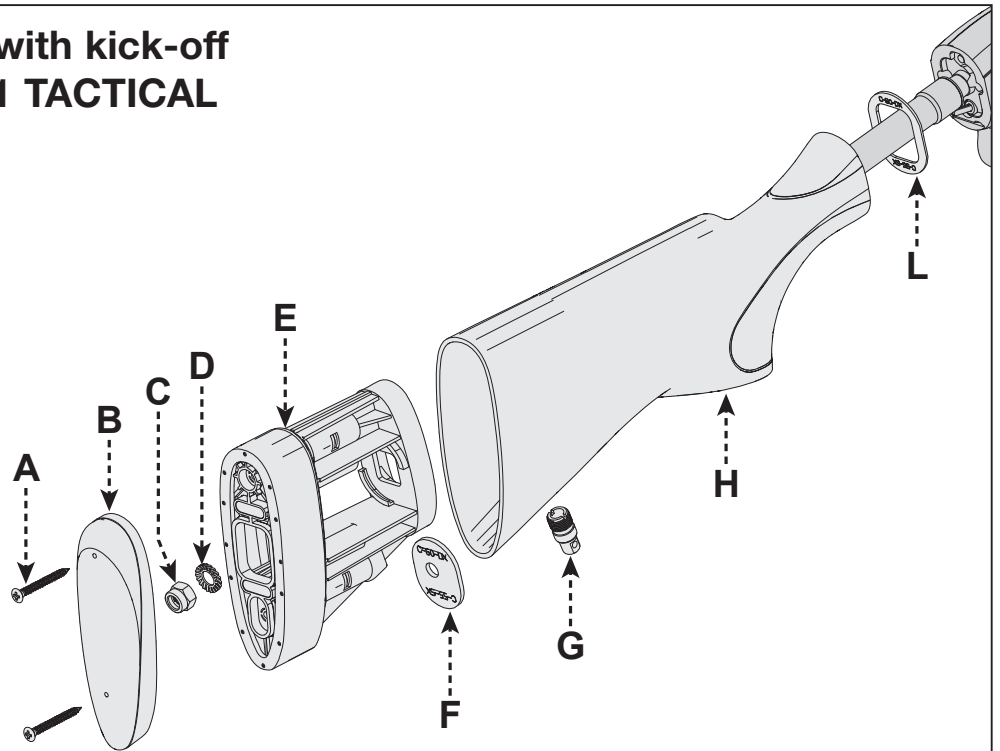

53

### STRIPPING

- Use the Phillips screwdriver to remove the two screws (A) sunk into the recoil pad.
- Remove the recoil pad (B).
- Use the 13-mm tube spanner to completely unscrew the retaining nut of the stock and remove the nut (C) and spring washer (D) inside.

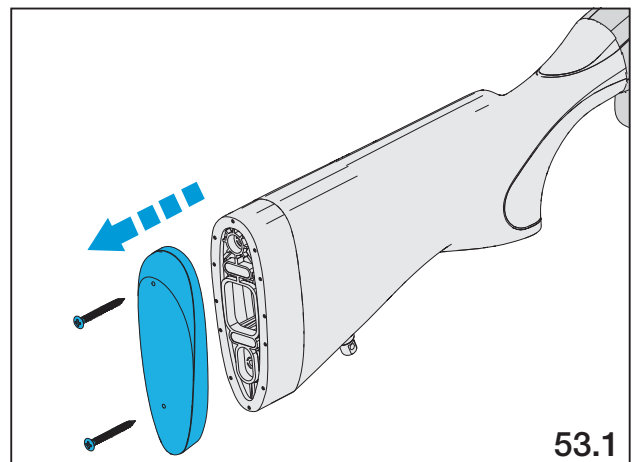

53.1

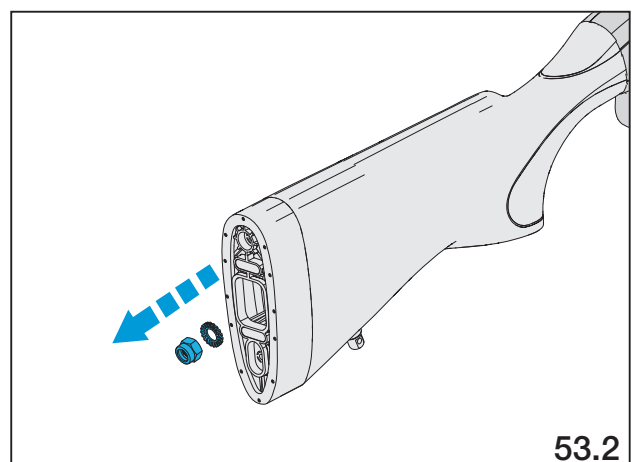

53.2

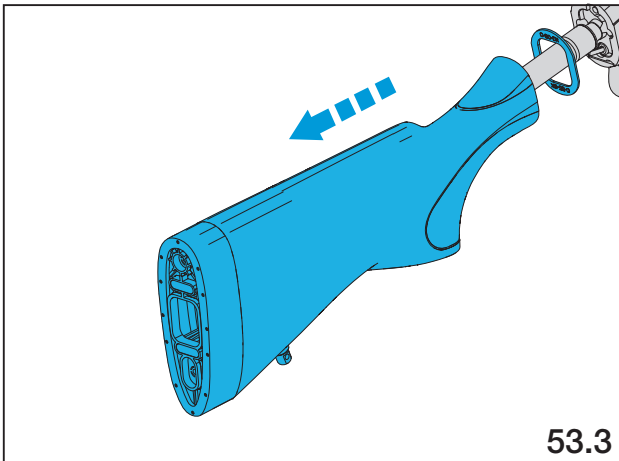

- Separate the stock (H) from the receiver and remove the front spacer (L).
- Unscrew the sling mount (G).
- Push the kick-off (E) out from the stock surface (H).
- Remove the spacer (F), turning it until it comes free of its seat.

### REASSEMBLY

- Carry out the above procedures in reverse order.

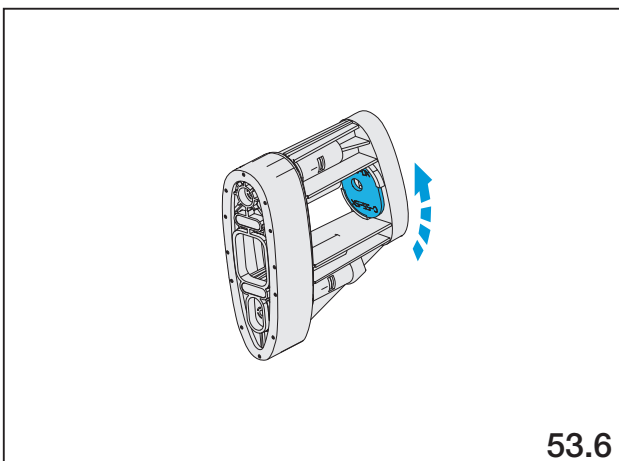
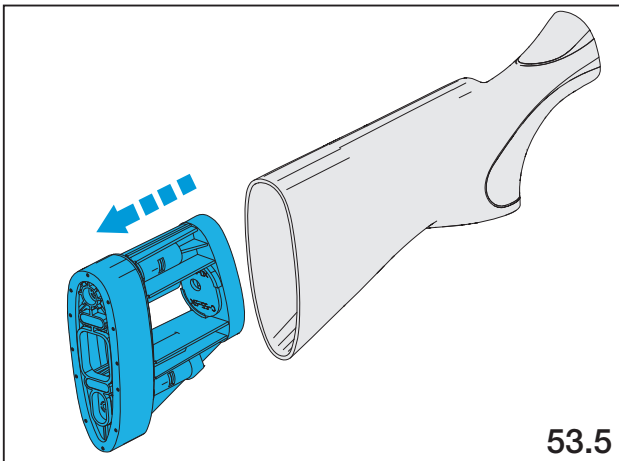
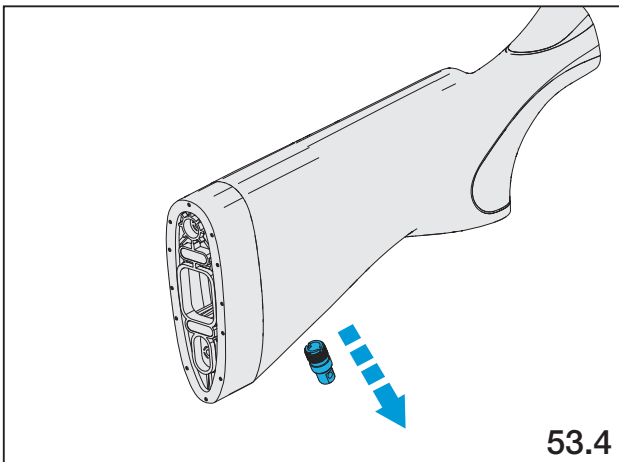

## Plastic stock without kick-off A350 and 1301 TACTICAL

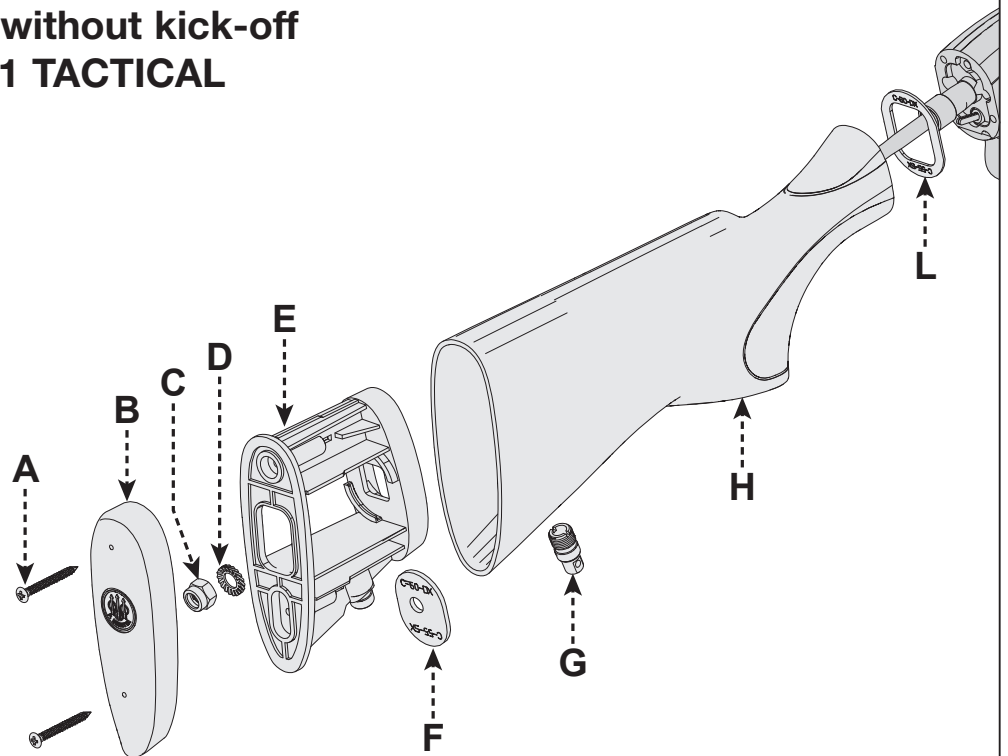

54

### STRIPPING

- Use the Phillips screwdriver to remove the two screws (A) sunk into the recoil pad.
- Remove the recoil pad (B).
- Use the 13-mm tube wrench to completely unscrew the retaining nut of the stock and remove the nut (C) and spring washer (D) inside.

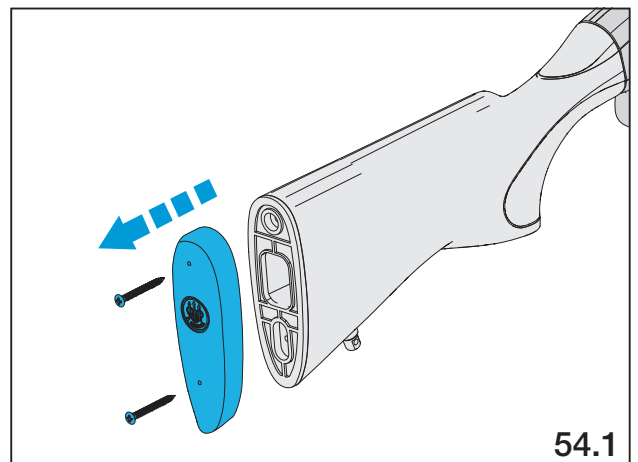

54.1

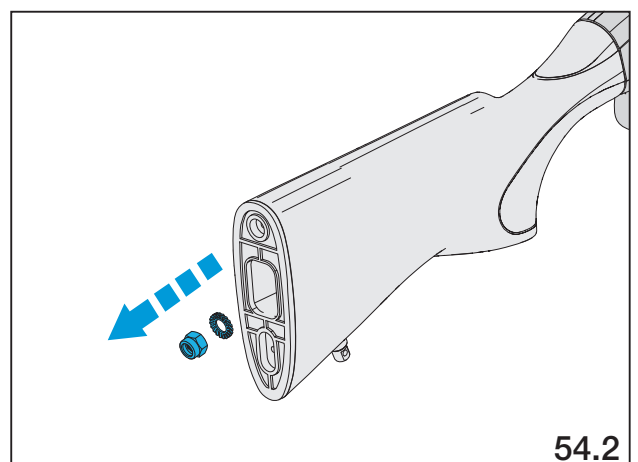

54.2

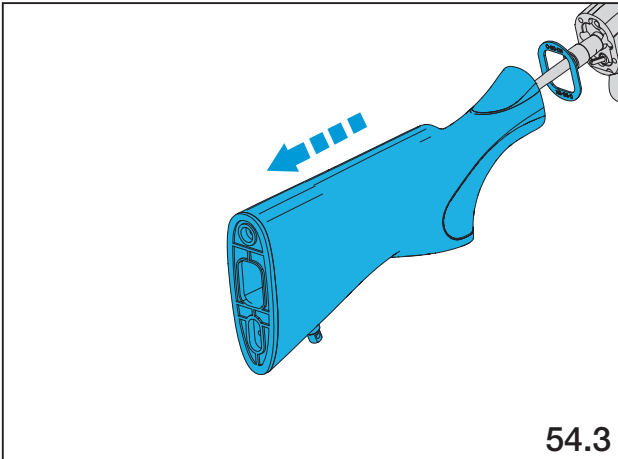

- Separate the stock (H) from the receiver and remove the front spacer (L).
- Unscrew the sling mount (G).
- Push out the insert (E) from the stock surface (H).
- Remove the spacer (F), turning it until it comes free of its seat.

### REASSEMBLY

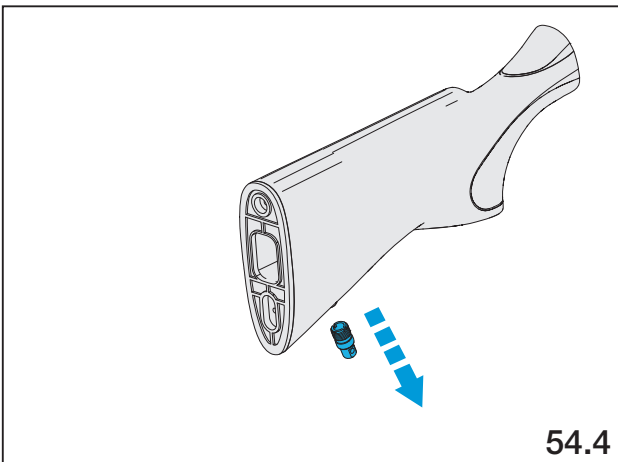

- Carry out the above procedures in reverse order.

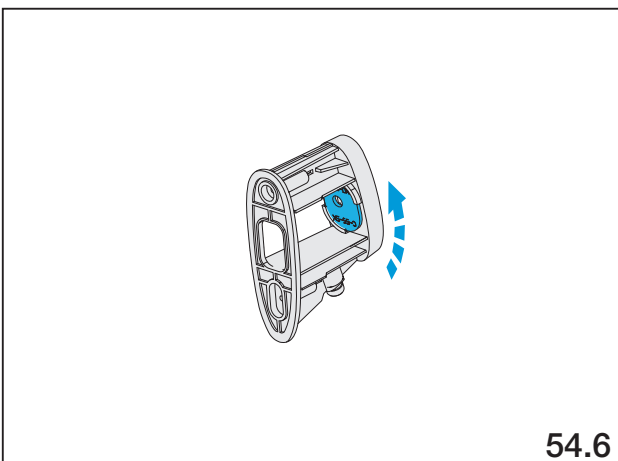
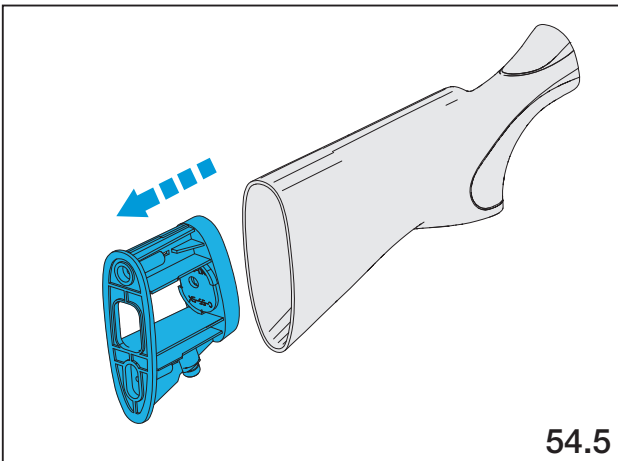

## Wooden stock without kick-off A300 OUTLANDER

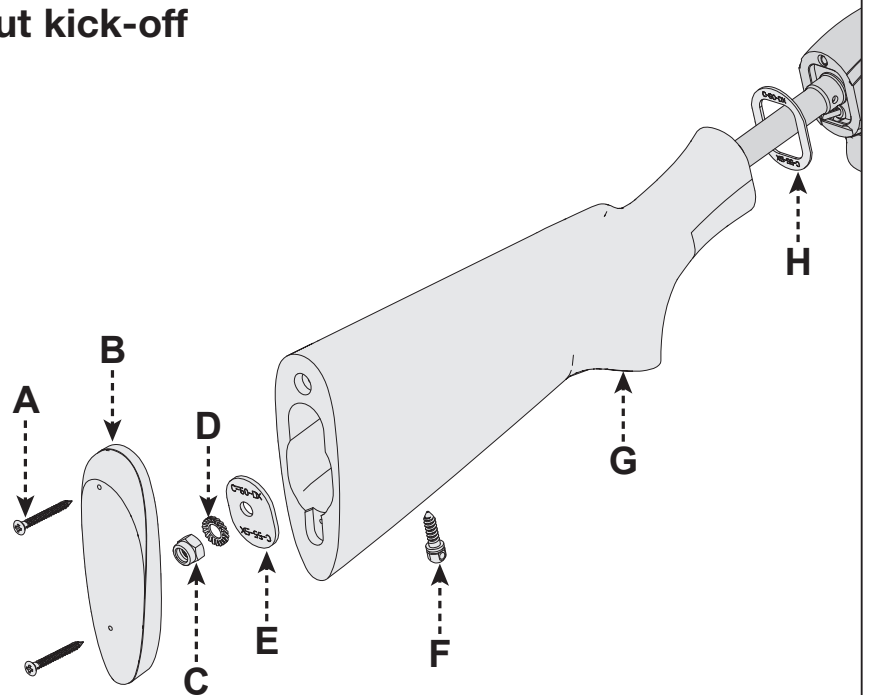

55

### STRIPPING

- Use the Phillips screwdriver to remove the two screws (A) sunk into the recoil pad.
- Remove the recoil pad (B).
- Use the 13-mm tube spanner to completely unscrew the retaining nut of the stock and remove the nut (C), the spring washer (D) inside and the rear spacer (E).
- Separate the stock (G) from the receiver and remove the front spacer (H).

### REASSEMBLY

- Carry out the above procedures in reverse order.

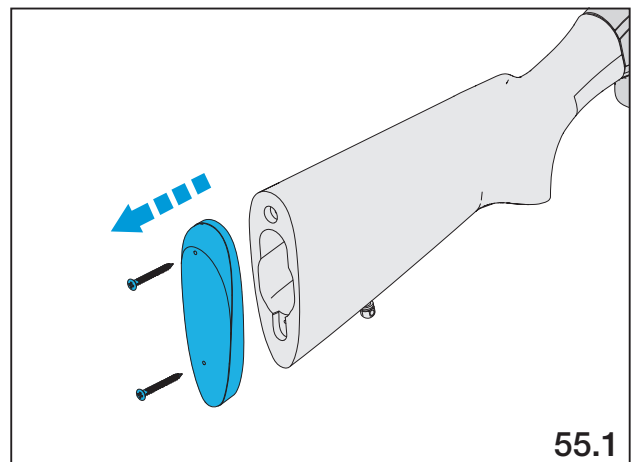

55.1

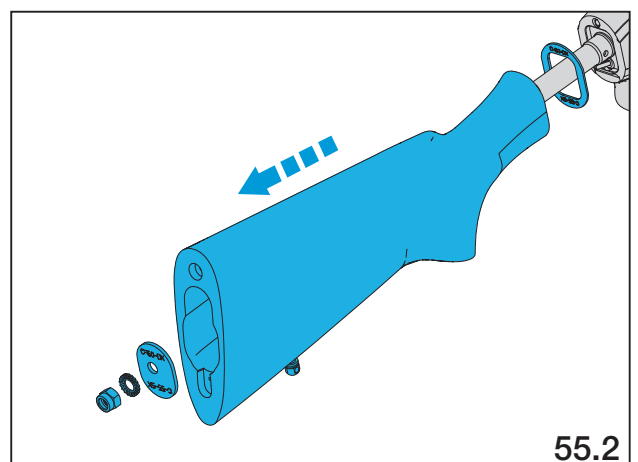

55.2

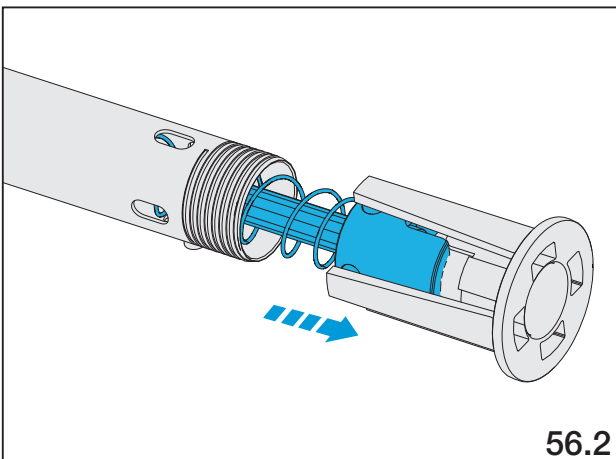
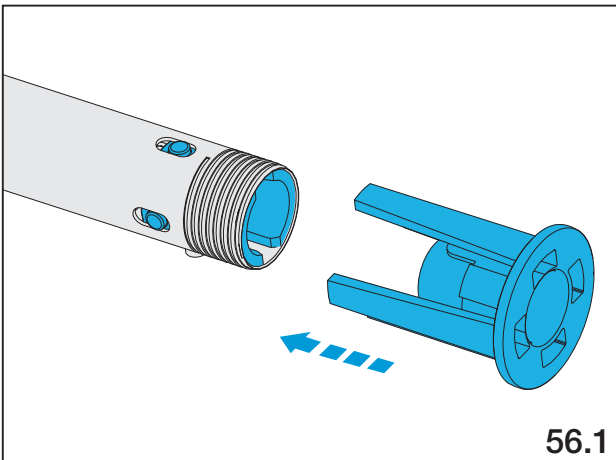
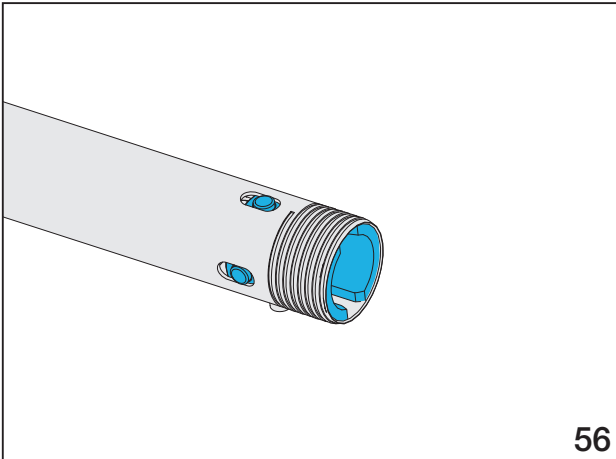

## MAGAZINE CAP FOR MODELS WITH B-LOCK CAP

### REMOVAL

- Remove the barrel (see "Barrel removal" on page 33).

### Notice

For these models, there is a specific tool to make it easier to remove the magazine tube cap. Proceed as follows:

- place the tool on the magazine tube so that the lugs meet the retaining slots in the cap (fig. 56.1);
- compress the lugs to release the cap retaining teeth.

### WARNING

**THE MAGAZINE TUBE CAP IS UNDER THE THRUST OF THE MAGAZINE TUBE SPRING: HOLD THE "TOOL-CAP" UNIT TOGETHER TO PREVENT IT COMING OUT SUDDENLY.**

**SLIDE THE TOOL OUT OF THE MAGAZINE TUBE, TOGETHER WITH THE CAP AND SPRING (FIG. 56.2).**



**INSTALLATION**

- Slide the magazine tube cap, complete with spring, into the magazine tube (fig. 56.3).
- Make sure the retaining teeth slot into the openings in the magazine tube (fig. 56.4).
- Continue to fit the barrel (see “Barrel reassembly” on page 42).

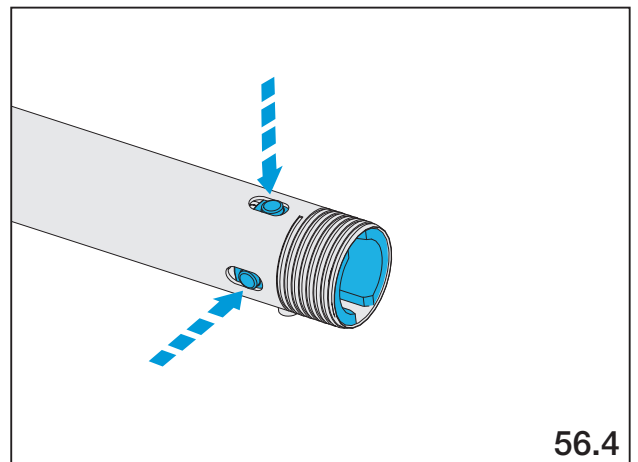
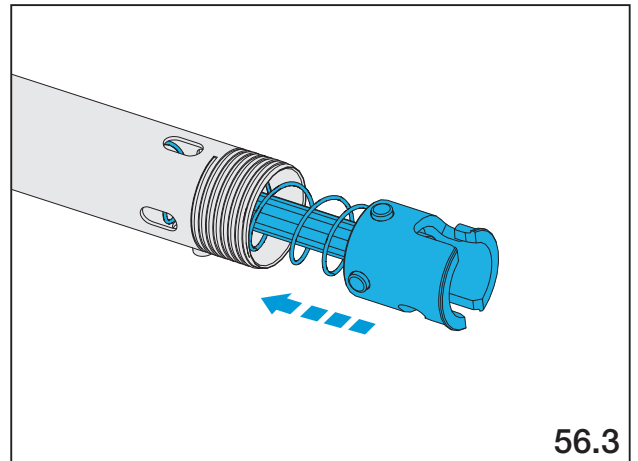

## B-FAST RIB ADJUSTMENT - FIG. 57

Some competition shotguns have an adjustable B-Fast rib to modify the point of impact on the target and alter the height of the rib.

The B-Fast rib has:

“a” retaining mechanism on the adjustment dial

“b” front adjustment mechanism

“c” rear adjustment mechanism (only for certain models)

- adjustment dial “D”
- adjustment dial stop “E”
- dial retaining screw “F”
- rib adjustment block “G”
- rib retaining screw “H”
- wrench (supplied) “L”
- screwdriver (supplied) “M”

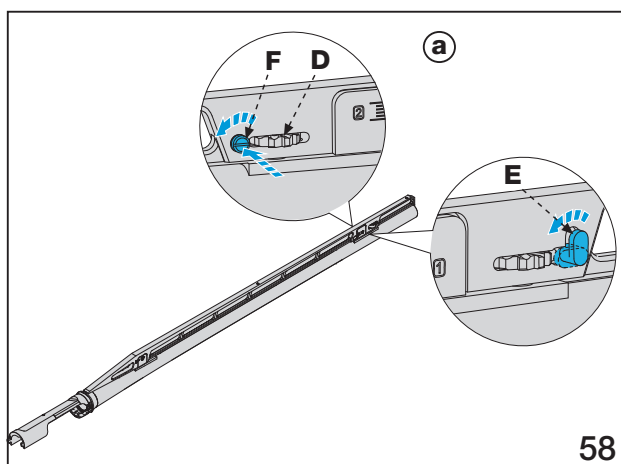
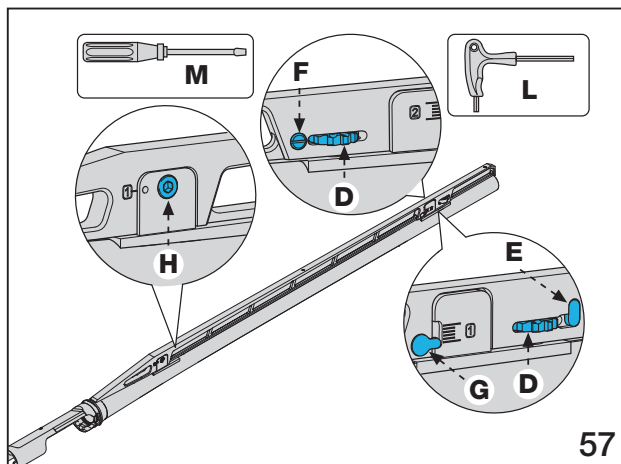

## Adjustment dial lock (a-fig. 58)

- Turn the screw “F” on the adjustment dial stop “E” and push it until the stop “E” is free to turn in its seat.
- Turn the stop “E” 90° and push it into the horizontal seat.
- Tighten the screw “F” all the way.

## Front mechanism (b-fig. 59)

The front mechanism “b” serves to adjust the impact point on the target with great precision. It has two graded scales:

- the scale “1”, located on the right side of the rib support, must be used when the rear mechanism “c” is in position 1;
- the scale “2” (only for certain models), located on the left side of the rib support, must be used when the rear mechanism “c” is in position 2.

The front mechanism also has an adjustment dial “D” to regulate the impact point on the target with great precision, lifting or lowering the front of the rib.

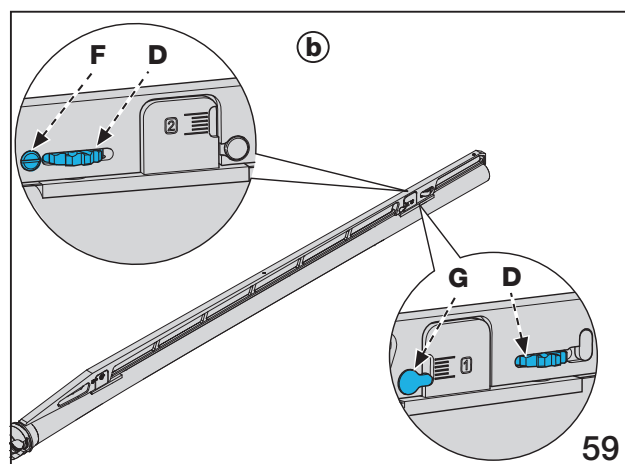

## CAUTION

Never turn the adjustment dial “D” without first loosening the retaining screw “F”.

## CAUTION

The rib adjustment block “G” must always be within the limits of the graded scale.

Exceeding these limits could provoke an annoying resonance effect when the gun is fired.

### Rear mechanism (c - fig. 60) (only on certain models)

The rear mechanism “c” serves to adjust the height of the rib with a choice of two positions:

- position “1” (written on the right side of the rib support) corresponds to a rib elevation of 25 mm;
- position “2” (written on the left side of the rib support) corresponds to a rib elevation of 30 mm.

### Rib elevation adjustment (models with rear adjustment only)

The shotgun is supplied with the rib in position 1, corresponding to 25 mm.

To increase the elevation to 30 mm, proceed as follows.

- Using the wrench (supplied) “L”, loosen the rear retaining screw of the rib “H”.
- Turn the adjustment dial “D” as far as the last notch at the top, taking care not to turn it too much.
- Loosen and remove the screw “H” (fig. 61).
- Raise the rib in correspondence with position 2 (written on the left side of the rib support).
- Insert the rib retaining screw “H” into its seat without tightening.
- Remove the adjustment block “G” (use the wrench “L” to simplify the procedure) (fig. 62).

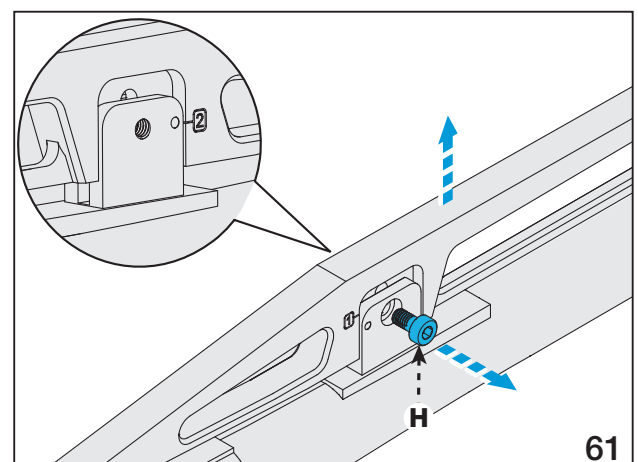
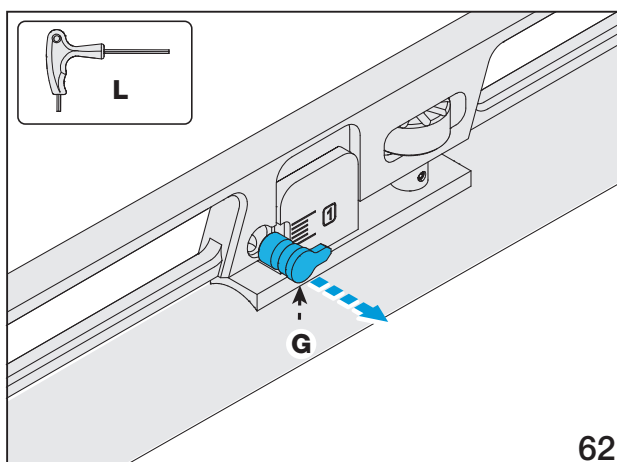
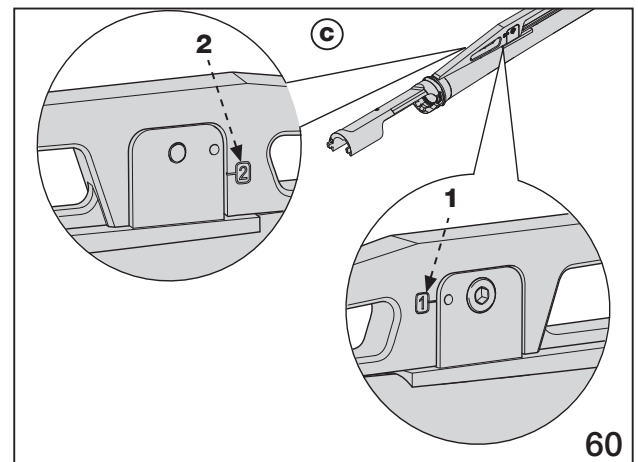

- Invert the position of the adjustment block “G”, inserting it into the seat on the left side (fig. 63).
- Tighten the retaining screw for the rib “H” completely (fig. 64).

### To modify the impact point on a target

- Using the wrench (supplied) “L”, loosen the rear retaining screw of the rib “H”, turning it anticlockwise by about 1 turn.
- Turn the adjustment dial “D” clockwise or anticlockwise until the required point of impact has been achieved.
- Turning the dial clockwise will raise the impact point, while turning it anticlockwise will lower the impact point.
- Once this adjustment is complete, tighten the retaining screw “H”, by turning it clockwise.

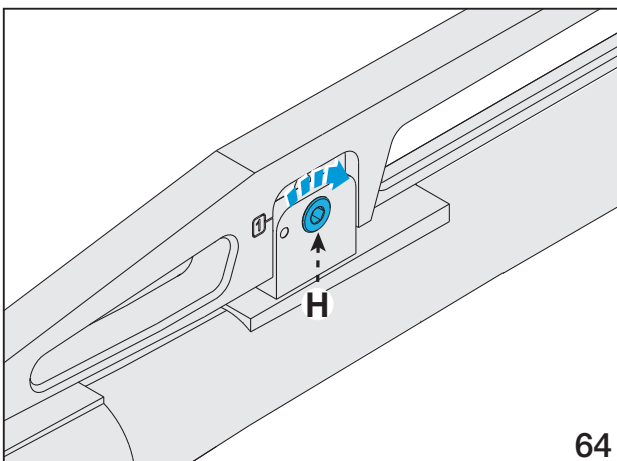
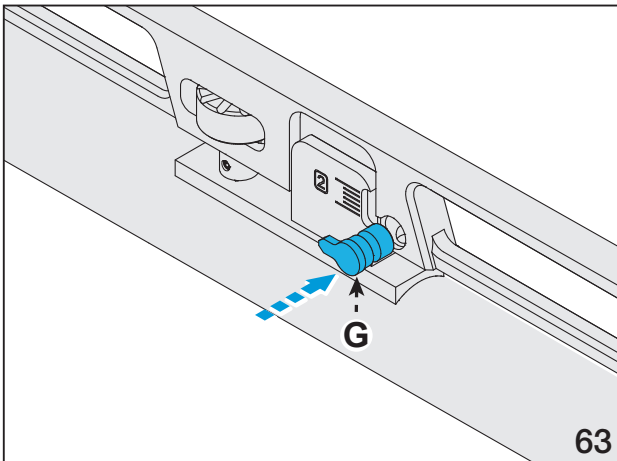

## STORAGE

### **WARNING**

**STORE YOUR SHOTGUN SO THAT CHILDREN CANNOT GAIN ACCESS TO IT. TO REDUCE THE RISK OF ACCIDENTS INVOLVING CHILDREN, UNLOAD YOUR SHOTGUN, LOCK IT AWAY AND STORE THE AMMUNITION IN A SEPARATE LOCKED LOCATION.**

### **CAUTION**

**Store the shotgun disassembled (barrels/fore-end and receiver/stock) in the supplied case. Before storage, always check the conditions of the shotgun and its case. Make sure that they are perfectly dry. Moisture and water drops could cause damage to the shotgun.**

### **CAUTION**

**Do not store the firearm in a leather, canvas or fabric case. These materials attract moisture, even though they may appear to be perfectly dry.**

## WARRANTY

### **CAUTION**

The Warranty and extension of the warranty period is packed with your shotgun Beretta. Please refer to the **WARRANTY** and the related instructions should a repair service be required under the warranty period.

### **Notice**

Wholesalers, dealers or gunsmiths are not authorized to carry out any Warranty repair or adjustment on behalf of the Manufacturer (unless they are a Repair Point authorized by the Manufacturer and/or by its Local Official Distributors).

### **Notice**

The warranty is only valid for the original purchaser.





SEMI-AUTO  
SHOTGUN  
USER MANUAL



FABBRICA D'ARMI P. BERETTA S.P.A.  
VIA PIETRO BERETTA, 18  
I 25063 GARDONE VAL TROMPIA, BRESCIA, ITALY

[BERETTA.COM](http://BERETTA.COM)