



OWNERS MANUAL

FOR 500[®], 505[™], 510[™], 535[™],
590[®] AND 835[®]

PUMP ACTION SHOTGUNS

IMPORTANT "SAFETY WARNINGS" - NOTE THE SYMBOL 

THESE SAFETY WARNINGS ARE FOR YOUR PROTECTION AS WELL AS THE SAFETY OF OTHERS. DISREGARDING INFORMATION IN THIS MANUAL COULD CAUSE SERIOUS INJURY OR DEATH TO YOU OR THOSE AROUND YOU.



Be certain this owner's manual is available for reference and is kept with this firearm if transferred to another party. If this manual is lost or misplaced, contact the Product Service Center for a free replacement copy or visit www.mossberg.com.



After performing any work on your firearm such as cleaning, adjustments, disassembly or installation of any accessory, the firearm should be rechecked for proper functioning before firing live ammunition.



Firearms are complex mechanisms. Any modification, alteration, or improper fitting of parts may result in a dangerous malfunction, damage to the firearm, and could cause serious injury or death to you or those around you. The firearm's owner must accept full responsibility for the correct reassembly and functioning of the firearm after any disassembly or replacement of parts.



If you do not understand any of the material in this manual or have any questions, contact the Product Service Center or a qualified gunsmith.



Do not attempt to load, handle or use your firearm until you read and understand the information contained in this owner's manual. Before handling your firearm, you should learn how it operates and how to maintain it. This includes knowing its basic parts, how the manual safety and other safety features operate, how to safely open and close the action and how to safely load and unload ammunition from the firearm. Improper use and handling is dangerous and could cause serious injury or death to you or those around you. All users of the firearm must become thoroughly familiar with the instructions in this manual.

O.F. MOSSBERG & SONS, INC.

P.O. BOX 497 • 7 GRASSO AVENUE, NORTH HAVEN, CONNECTICUT 06473
PHONE (800) 363-3555
www.mossberg.com

Safety and safe firearms handling is everyone's responsibility.



As the owner of a firearm, you must undertake the full-time responsibility of safe firearms handling for your own safety and the safety of those around you:

- Keep all firearms and ammunition out of the reach of children.
- Store your firearms and ammunition separately.
- Never store a loaded firearm.
- Never leave a loaded firearm unattended.
- Never transport a loaded firearm in a vehicle.
- Unload your firearm when you have stopped shooting and when you have to climb a tree, fence, cross a slippery surface or have to transport it in a vehicle.
- The safety should remain fully in the “ON” (SAFE) position and the firearm unloaded at all times until you are in a place where it is safe to shoot, keeping your finger off the trigger and outside of the trigger guard until you are aiming at the intended target and have decided to fire.
- Never shoot at water, rocks or any hard surface. Shots may glance off such surfaces and cause injuries.
- Do not use alcohol or drugs before or while handling firearms.
- Do not touch the trigger while the safety is being engaged or disengaged.



Always point the muzzle of your firearm in a safe direction, regardless of whether the firearm is loaded or unloaded. You should become thoroughly familiar with the function and operation of this firearm and the instructions supplied with it.



Always treat every firearm as if it is loaded. Give your firearm to someone with the action open (bolt fully rearward), and the safety fully in the “ON” (SAFE) position, after you verify the firearm is unloaded. Insist on the same procedure when receiving a firearm from someone else. Learn the location of all the safety features of your firearm and how they operate.



Always wear eye and ear protection when shooting. Shooting without proper ear protection can cause hearing damage. The use of eye protection during any type of shooting is important to protect your vision.



When using a firearm with mounted optics, maintain an adequate distance between the rear of the scope and your face at all times. Be certain the scope installation does not interfere with access to, or the proper functioning of the safety.



We specifically disclaim any responsibility for damage or injury whatsoever occurring in connection with, or as a result of, the use of faulty, or non-SAAMI standard, or “remanufactured”, or hand-loaded (reloaded) ammunition. Additionally, we disclaim any responsibility for damage or injury which results from any modifications or changes that are not a part of the firearm as delivered from the factory.



Learn to clean your firearm thoroughly and make certain no oil, grease or other materials are blocking the barrel. Obstructions of any kind can cause damage to the firearm and could cause serious injury or death to you or those around you.

Practice proper firearm maintenance and safety. Make sure all exposed metal surfaces are coated with a thin film of oil, especially after being exposed to damp weather. (See “Cleaning and Lubrication” section of this manual) Do not plug the barrel or store in a fabric-lined case, which will absorb lubricants from the firearm. Before using after storage, follow complete instructions stated in this manual for re-familiarization with the firearm. A thorough inspection and function test should be performed before going into the field. Have your firearm periodically checked by a qualified gunsmith.



A note about the warnings and information contained in this manual:

We strongly suggest that you check with your local licensed retailer or state police for additional information concerning firearms ownership, or hunting or target shooting rules that may be required by local law or regulation. Since such rules and regulations are subject to change, local authorities are in the best position to advise you on such matters.

TABLE OF CONTENTS

	Page
GENERAL INFORMATION AND MECHANICAL CHARACTERISTICS.....	4
MECHANICAL SAFETY.....	5
ACTION RELEASE CONTROL.....	6
BARREL ASSEMBLY.....	6-7
MAGAZINE CAPACITY.....	8
LOADING.....	8-9
FIRING.....	10
UNLOADING.....	10-11
DISASSEMBLY.....	11-14
CLEANING AND LUBRICATION.....	14-15
ASSEMBLY.....	15-17
FUNCTION TESTING.....	18
LIGHTNING PUMP ACTION™ TRIGGER SYSTEM ADJUSTMENTS.....	18-20
SIGHT ADJUSTMENTS.....	20
ACCESSORY BARRELS.....	21
PISTOL GRIP INSTALLATION.....	21
+4 SHELL HOLDER STOCK.....	22
6-POSITION ADJUSTABLE TACTICAL STOCK.....	23-26
HEAT SHIELD.....	27-28
DUAL-COMB® TROPHY STOCK.....	28
ACCU-CHOKE™ AND ACCU-MAG CHOKE™ TUBES.....	28-31
MUZZLELOADER CONVERSION BARREL.....	31
SERVICE INSTRUCTIONS.....	32
WARRANTY INFORMATION.....	33
PARTS LIST.....	34
EXPLODED VIEW.....	35
NOTES.....	36-37
THE BASIC RULES OF FIREARM HANDLING.....	BACK COVER



WARNING: This product can expose you to chemicals, including lead, which are known to the State of California to cause cancer and birth defects or other reproductive harm. For more information go to www.P65Warnings.ca.gov.

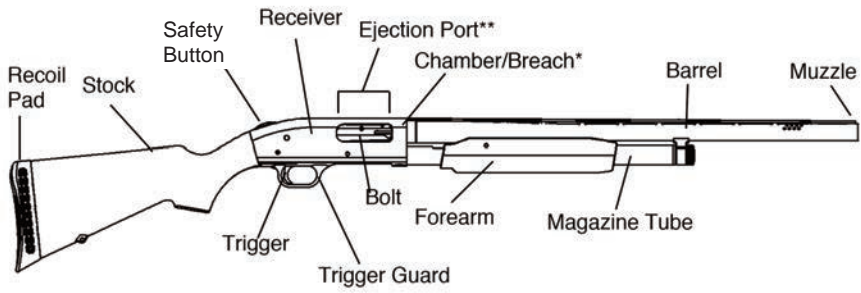

GENERAL INFORMATION AND MECHANICAL CHARACTERISTICS**Fig. 1**

*The chamber is the rearmost part of the inside of the barrel. The breach is the rear face of the barrel. They can only be seen when the bolt is in the "open" position.

**On left hand models the ejection port is on the opposite side of the receiver.



Read and understand this entire manual and its safety warnings before firing the firearm.

MECHANICAL SAFETY

The safety button is located on the top rear portion of the receiver (Fig. 2) and must be manually moved to the desired position by the shooter.



Remember, a firearm's manual safety is a mechanical device which can never replace safe firearm handling practices.



Because any mechanical device can fail, never rely on any mechanism or safety device to prevent the dangers of careless handling or pointing a firearm in an unsafe direction.

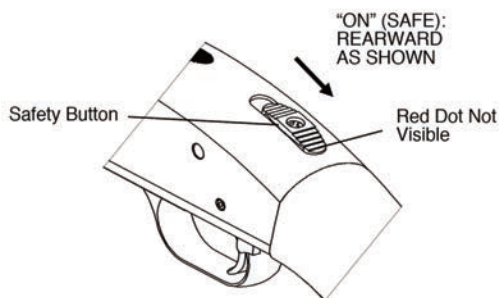

Fig. 2

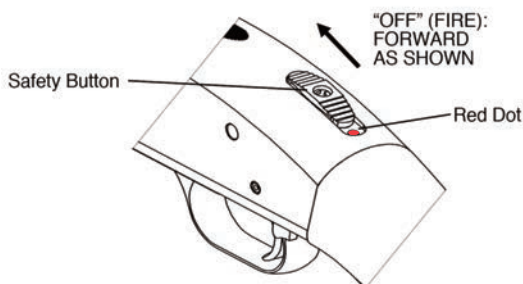

Fig. 3



The safety is set in the "ON" (SAFE) position by moving the safety button fully rearward into the safety detent. The button will now cover the red dot (Fig. 2). The red dot is a training aid used only to show the direction of the "ON" (SAFE) position and should not be used as an indicator that the safety is "ON" or "OFF."



The safety is set in the "OFF" (FIRE) position by moving the safety button to the forward position. The red dot will now be visible (Fig. 3).



The safety should remain fully rearward in the "ON" (SAFE) position and the firearm unloaded at all times until you are in a place where it is safe to shoot, keeping your finger off the trigger and outside of the trigger guard until you are aiming at the intended target and have decided to fire.



ACTION RELEASE CONTROL

The action lock lever is located on the left side of the trigger housing just rearward of the trigger guard. The action lock lever allows the action to be unlocked and opened for inspection of the chamber and action or unloading without pulling the trigger. The action may be opened by depressing the lever and pulling the forearm rearward (Fig. 4).

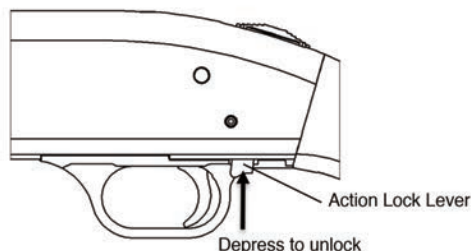

Fig. 4

BARREL ASSEMBLY



Barrels are **not** interchangeable between model numbers, gauge, or capacity. **500**[®], **505**[™], **510**[™], **535**[™], **590**[®] and **835**[®] barrels are interchangeable only with barrels of the same model, gauge and capacity. Right and left hand model barrels are not interchangeable.

CAUTION: Never close the action or pull the trigger while the barrel is removed as damage could result to the firearm.

To facilitate shipping, some models are packaged with the barrel removed. A front swivel stud and washer are also shipped separately on some models (see items 35 and 36 in exploded view). To install the barrel in the receiver, proceed as follows:



Visually and physically inspect the chamber and bore of the barrel to make certain it is unloaded and that it is free of any obstructions, excessive oil or grease. If you are unable to remove all obstructions, bring the firearm to a qualified gunsmith or send it to the authorized Product Service Center. Obstructions of any kind can cause damage to the firearm and could cause serious injury to you or those around you.



Move the safety button fully rearward to the “ON” (SAFE) position.

CAUTION: Wear eye protection to protect your eyes from spring loaded components.

All Models: Depress the action lever and move the forearm rearward until the front of the bolt is in the middle of the ejection port (Fig. 5).

590[®] and 835[®] Models: Unscrew the magazine cap by turning it counterclockwise.

Slide the barrel takedown mount ring over the magazine tube while guiding the barrel into the receiver (Fig. 5).

Gently rotate the barrel back and forth while pushing the barrel into the receiver.



Slide the barrel into the receiver and tighten the magazine cap, finger tight only. DO NOT use pliers or a wrench to tighten magazine cap.

If your 590/835 shotgun is equipped with a magazine spring retainer, prior to putting on the magazine cap, assemble the magazine spring retainer over the protruding magazine spring. Push the retainer downward inside of the magazine tube so that the spring retainer is flush with the magazine tube end.

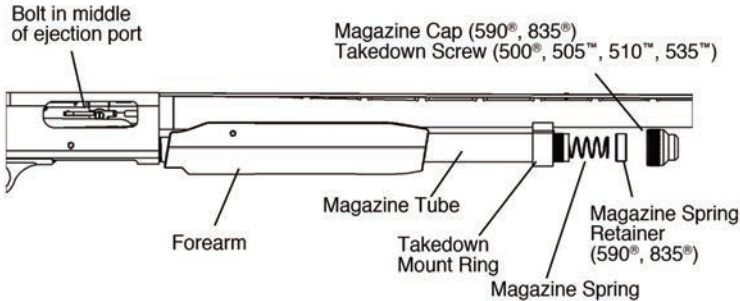

Fig. 5

**500®, 505™,
510™, and
535™
Models:**

Slide the barrel into the receiver and tighten the takedown screw, finger tight only. DO NOT use pliers or a wrench to tighten the takedown screw. A little space between the magazine tube and the takedown mount is normal.



WARNING (All Models): Check to be certain that the barrel is fully seated into the receiver by looking through the ejection port. The barrel extension must rest firmly against the corresponding cut in the top of the receiver (Fig. 6).

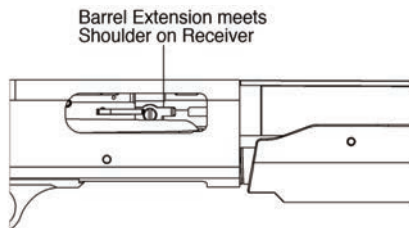

Fig. 6

**Swivel Stud
Installation:**

Place the washer over the swivel stud thread. Screw the stud into the magazine cap or takedown screw (depending on model) and tighten, making sure the through-hole is oriented horizontally. Use caution not to over-tighten the stud as this may strip the threads in the magazine cap or takedown screw.



MAGAZINE CAPACITY

- 835® Models:** Total ammunition capacity (including one in the chamber) is six (6) 2-3/4" or 3" shotshells or five (5) 3-1/2" shotshells.
- 535™ Models:** Total ammunition capacity (including one in the chamber) is five (5) 2-3/4" or 3" shotshells or four (4) 3-1/2" shotshells. Depending upon tolerance variations, total capacity may be reduced by one shotshell when using 3" shotshells.
- 500® Models:** Total ammunition capacity (including one in the chamber) is six (6) 2-3/4" shotshells or eight (8) 2-3/4" shotshells depending on item number. Depending upon ammunition tolerance variations, total capacity may be reduced by one shotshell when using 3" shotshells.
- 505™ and 510™ Models:** Total ammunition capacity (including one in the chamber) is four (4) or five (5) 2-3/4" or 3" shotshells or five (5) 2-1/2" shotshells depending on item number. Depending upon ammunition tolerance variations, total capacity may be reduced by one shotshell when using 3" shotshells.
- 590® Models:** Total ammunition capacity (including one in the chamber) is six (6) 2-3/4" shotshells or nine (9) 2-3/4" shotshells depending on item number. Depending upon ammunition tolerance variations, total capacity may be reduced by one shotshell when using 3" shotshells.

NOTE: To comply with U.S. migratory bird laws, all four, five and six shot models are shipped with a wooden dowel inserted in the magazine tube which limits magazine capacity to two (2) shotshells.

To remove the dowel: First remove the barrel per the instructions in the "Disassembly" section of this manual. Point the shotgun downward and shake it back and forth lightly until the dowel protrudes from the takedown screw hole at the end of the magazine tube. A rubber "O" ring on the dowel prevents it from falling out accidentally. Grasp the dowel and pull it out completely.

To change back to a 2-shot magazine capacity insert the dowel through the center of the magazine spring so that it is positioned inside the coils of the spring.

500® Bantam™, Super Bantam, 505™, and 510™ Models: These Models are supplied as a single shot. An extra-long wooden dowel blocks magazine loading. After proper firearm training the dowel can be removed to be cut to 9" to comply with appropriate laws.

LOADING



Before loading, move the safety button fully rearward to the "ON" (SAFE) position.



During loading, never allow fingers or any objects to contact the trigger. Keep the muzzle pointed in a safe direction at all times.

Depress the action lock lever and open the action by pulling the forearm completely rearward.



Do not load firearm until ready to use! Unload firearm when shooting has been completed! The safety button should always be fully rearward in the "ON" (SAFE) position whether or not the firearm is loaded.





Inspect the chamber and bore of the barrel for any obstruction, excessive oil or grease. (The chamber is the rear portion of the barrel which contains the shotshell.) Obstructions of any kind can cause damage to the firearm and may result in serious personal injury to the shooter and/or others nearby.



Check to be certain that the ammunition selected is the same type of shotshell as designated on the left side of the barrel.

835[®] Models are designed for factory loaded 12 gauge 2-3/4", 3", and 3-1/2" shotshells. Do not fire slugs of any type (single projectile ammunition) through the overbored 835[®] Accu-Mag[™] barrel. This barrel is designed to shoot lead or steel pellet shot loads only. Use only 835[®] barrels designated specifically for slug shooting.

535[™] Models are designed for factory loaded 12 gauge 2-3/4", 3", and 3-1/2" shotshells.

590[®] Models are designed for factory loaded 12 gauge 2-3/4" and 3" shotshells.

500[®], 505[™], and 510[™] Models are designed for factory loaded 12, 20 gauge or .410 (depending on item number) 2-3/4" and 3" shotshells (2-1/2" .410 bore).

Fully rifled barrels deliver best accuracy with sabot style slugs. "Rifled" slugs and shotshells are not recommended for use in rifled barrels.

If you wish to load the firearm with the maximum number of shotshells, or fire single shots, load the first shotshell through the ejection port (Fig. 7). The shotshell can be inserted directly into the chamber or placed on top of the elevator. Close the action by moving the forearm completely forward. Be sure to leave the safety button fully rearward in the "ON" (SAFE) position until you are ready to shoot.

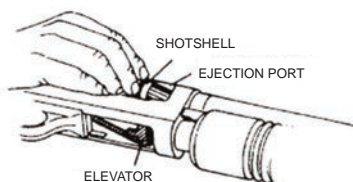

Fig. 7



The firearm is now loaded and will fire if the safety button is moved to the "OFF" (FIRE) position and the trigger is pulled. Keep the muzzle pointed in a safe direction at all times.

LOADING THE MAGAZINE

Load the magazine tube by turning the shotgun so that the trigger guard is facing up and the action is closed. Push the front end of the shotshell into the magazine tube until the rim of the shotshell snaps past the cartridge stop (Fig. 8). Never attempt to exceed the magazine capacity.

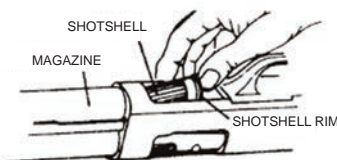

Fig. 8



FIRING



Use of this product, including discharging firearms in poorly ventilated areas, cleaning firearms, or handling ammunition can result in exposure to chemicals, including lead, which are known to the state of California to cause serious physical injury, including cancer, birth defects or other reproductive harm. For more information, go to www.P65Warnings.ca.gov.

Have adequate ventilation at all times and wash hands thoroughly after exposure.

With the firearm pointed in a safe direction and held in the proper firing position, move the safety button fully forward to the “OFF” (FIRE) position. Pulling the trigger through its full travel to the rear will cause the firearm to fire. Ensure muzzle is pointed in a safe direction before placing finger on trigger.



Should any shotshell fail to fire, keep the muzzle pointed in a safe direction for at least thirty (30) seconds in case the shotshell is a “hangfire” (delayed firing of the shotshell after being struck by the firing pin.) Move the safety button fully rearward to the “ON” (SAFE) position. Pull the forearm fully rearward so that the action is in the open position extracting and ejecting the misfired shotshell. Segregate the misfired shotshell from other ammunition. Do not attempt to refire a misfired shotshell.



If at any time during firing, the sound of any shotshell is noticeably louder or softer than previous shotshells fired, STOP! Do not load or fire additional shotshells. Move the safety button fully rearward to the “ON” (SAFE) position. Keep the muzzle pointed in a safe direction and, while keeping the ejection port and loading port opening of the firearm turned away from your face (to protect your eyes in the event a defective shotshell explodes), visually and physically verify that the chamber is empty. Safely unload your firearm and inspect it for possible damage or obstructions in the chamber or bore. Firing the firearm with a bore obstruction can cause damage to the firearm and may result in serious personal injury to the shooter and/or others nearby.

CYCLING THE ACTION

To eject a shotshell case, pull the forearm completely rearward. The spent case or unfired shotshell will eject out of the receiver through the ejection port.



Be sure that all observers are clear of the path of ejection. Empty cases are thrown out with significant force and could cause injury.

To chamber a live shotshell from the magazine, push the forearm fully forward.



Remember: when the magazine tube is loaded and the action is cycled, a live shotshell will be chambered! Always keep the safety button fully rearward in the “ON” (SAFE) position until you have actually decided to fire.

UNLOADING



Move the safety button fully rearward to the “ON” (SAFE) position and keep the muzzle pointed in a safe direction while unloading the firearm.

Depress the action lock lever and pull the forearm rearward, slowly, until the live shotshell is completely withdrawn and visible in the ejection port. Remove shotshell by hand.

Pull forearm completely rearward to release the next shotshell onto the elevator.



Turn the shotgun so that the ejection port faces downward to allow the released shotshell to drop out through the ejection port.

Push the forearm completely forward, closing the bolt **without** a shotshell being chambered.

Turn the shotgun over so that the trigger guard is positioned upward and the shotgun remains pointed in a safe direction.

Insert your thumb into the opening in the bottom of the receiver and depress the cartridge stop on the right side to release shotshells one at a time (Fig. 9). Repeat until all shotshells are removed from the magazine tube. On left hand models the cartridge stop is in the same location as shown below.

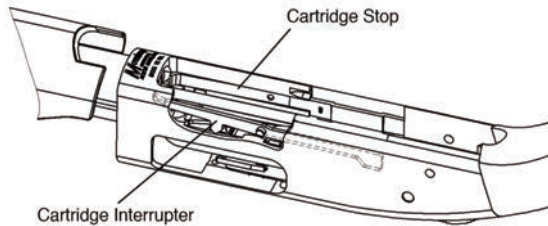

Fig. 9



Depress the action lock lever and pull the forearm completely rearward. Visually and physically inspect chamber, elevator and magazine tube to be certain the shotgun is completely unloaded.

Leave the action in the open, rearward position and the safety button fully rearward in the "ON" (SAFE) position.

DISASSEMBLY



Move the safety button fully rearward to the "ON" (SAFE) position and visually and physically check the chamber, elevator, and magazine tube to be certain the shotgun is unloaded before disassembling the firearm. Wear eye protection during disassembly and cleaning to protect your eyes from oil splatter or spring loaded components.

Depress the action lock lever and open the action by sliding the forearm fully rearward.

Move the forearm slowly forward from the fully rearward position until the front of the bolt is in the middle of the ejection port.

590® and 835® Models: Unscrew the magazine cap by turning it counterclockwise (Fig. 10).

CAUTION: The **590® and 835® Model** magazine spring retainers and springs are under significant spring pressure. Use caution to prevent injury to yourself or others around you.

500®, 505™, 510™, and 535™ Models:

Loosen the takedown screw by turning it counterclockwise until the screw threads are completely disengaged from the end of the magazine tube (Fig. 10).

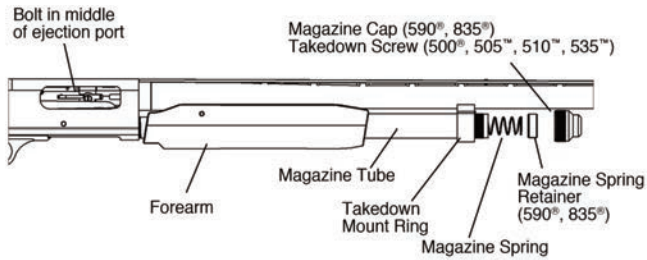

Fig. 10

Remove the barrel from the receiver with a gentle back-and-forth rotational movement while pulling the barrel out of the receiver assembly.

TRIGGER HOUSING ASSEMBLY REMOVAL

Position the shotgun on a clean surface with the trigger guard upward. With a punch (no greater than 3/16" [4.76 mm] diameter), push out the small diameter trigger housing retainer pin located on the side of the receiver, approximately a 1/2" (12.7 mm) below the rear of the trigger guard (Fig. 11).

Remove the trigger housing assembly by lifting the rear portion upward first.

The trigger housing assembly is a complex assembly and must not be disassembled. Disassembly should only be performed at an authorized Product Service Center or by a qualified gunsmith.

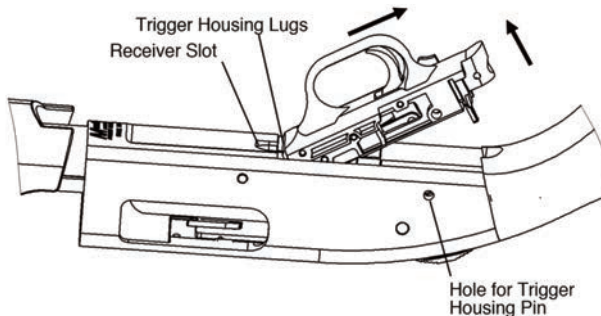

Fig. 11



Do not pull the trigger and allow the hammer to fall when the trigger housing assembly is removed from the receiver. To do so may result in personal injury and/or damage to the assembly.

CAUTION: Before performing any further disassembly, take time to study how the internal components are arranged inside the receiver.

DISASSEMBLY OF INTERNAL RECEIVER COMPONENTS

CAUTION: Pay special attention to the position of the bolt, bolt slide and action slide bar assembly during this portion of the disassembly, as the parts must be in the same relationship during reassembly.

Remove the cartridge interrupter and cartridge stop from the receiver. (It may be necessary to tap the sides of the receiver lightly to release these parts) (Fig. 12).

On left hand models the positions of the cartridge stop and cartridge interrupter remain the same as shown but the ejection port is on the opposite side.

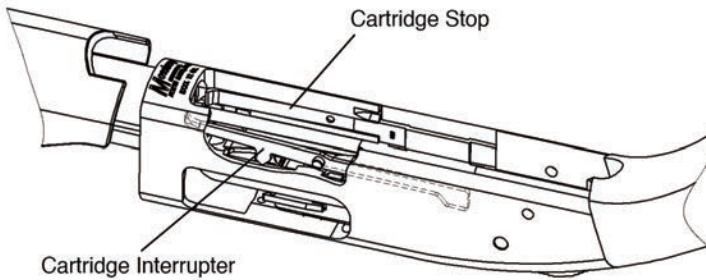

Fig. 12

Move the forearm/action slide assembly rearward so that the bolt assembly and bolt slide are three quarters of the way rearward. When the bottom of the bolt slide is aligned with the clearance cuts in the sides of the receiver, lift the bolt slide upward and out of the receiver (Fig. 13).

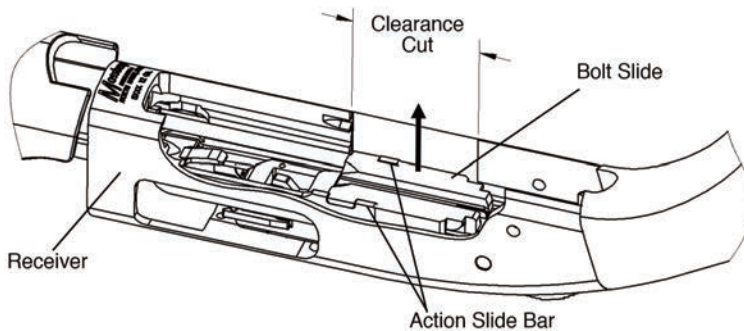

Fig. 13

Remove the bolt assembly by sliding it forward and out of the receiver assembly through the barrel opening at the front of the receiver (Fig. 14-A).

NOTE: The safety button must be fully rearward in the “ON” (SAFE) position to remove the elevator assembly.

Pivot the front portion of the elevator upward out of the receiver (Fig. 14-B). Squeeze the two arms which form the open end of the elevator assembly together sufficiently to disengage and remove the elevator from the receiver (Fig. 14-C).

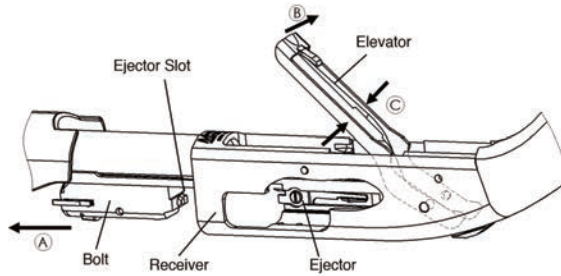

Fig. 14

Remove the forearm/action slide assembly by sliding it forward and off the magazine tube.



CAUTION: Field disassembly is now complete! The shotgun should not be disassembled further for routine cleaning or maintenance. Further disassembly should only be performed by an Authorized Product Service Center or by a qualified gunsmith.

CLEANING AND LUBRICATION

With proper maintenance and care, your Mossberg® firearm will provide you with years of dependable service. Your firearm should be inspected and cleaned periodically to ensure that it remains in good condition. Clean your firearm as soon as possible after use. This is especially important if your firearm has been exposed to moisture. For maximum performance and continued satisfaction with your firearm, periodic cleaning and lubrication are essential.

Follow the instructions and equipment provided with a quality gun cleaning kit.



Always be sure that the safety button is fully rearward in the “ON” (SAFE) position and that the firearm is unloaded by visually and physically checking the chamber, elevator, and magazine tube before cleaning your firearm. Wear eye protection during cleaning to protect your eyes from oil splatter and spring loaded components.

Normal use requires only that the mechanisms be free of excessive shooting residue. Very little lubrication other than a light oiling of internal and external surfaces to prevent rust is needed.

To ensure optimum performance, Mossberg® recommends thorough cleaning of your firearm after every 200 shotshells. However, unusually dusty, dirty, or harsh weather conditions, or use of ammunition which leaves significant powder residue may require more frequent cleaning.

If the firearm is to be stored for a long period of time, it should be thoroughly cleaned and oiled. Do not plug the barrel or store in a fabric-lined case that will absorb lubricant from the firearm, as this may result in corrosion to the unprotected metal surfaces.

Over-lubrication should be avoided during below freezing conditions. Many lubricants thicken in low temperatures which could affect the operation of the firearm. Exposure to unfavorable weather or moisture from condensation requires additional care to prevent corrosion to the firearm.

BARREL CLEANING

Scrub bore and chamber with solvent and follow with cleaning patches until barrel is clean. A final pass with a lightly oiled patch will provide a protective coating. A stiff brass bristle brush is useful for removing stubborn deposits.



Be sure not to leave cleaning patches or excessive oil or grease in the bore as they can create dangerous obstructions. Obstructions of any kind can cause damage to the firearm and could cause in serious injury or death to you or those around you.

ACTION CLEANING

Clean all components of the action including the bolt, bolt slide and action slide bars to remove accumulated residue. An evaporating solvent should be used. Action parts will remain cleaner longer if lubrication is used sparingly.

RECEIVER CLEANING

Clean the inside of receiver with a rag or soft brush, giving special attention to the tracks which guide the bolt and bolt slide. Place a few drops of light oil in these tracks when clean. Care should be taken when cleaning the exterior surfaces of the receiver to prevent cosmetic damage. Never use a brush with metal bristles, as this could remove the protective coating on the receiver.

TRIGGER HOUSING CLEANING

Brush loose residue from trigger housing with a soft bristle brush. Never use a brush with metal bristles, as this could remove the protective coating on the trigger housing.



Never pull the trigger while the trigger housing is removed from the receiver, as damage to the trigger housing and/or personal injury may result.

ASSEMBLY

ASSEMBLY OF INTERNAL RECEIVER COMPONENTS

Place the receiver with the trigger housing opening upward on a clean surface.

Check to be certain that the safety button on the top rear of the receiver is fully rearward in the "ON" (SAFE) position. Slide the forearm assembly onto the magazine tube while guiding the action slide bars into the corresponding cuts in the front of the receiver (Fig. 15).

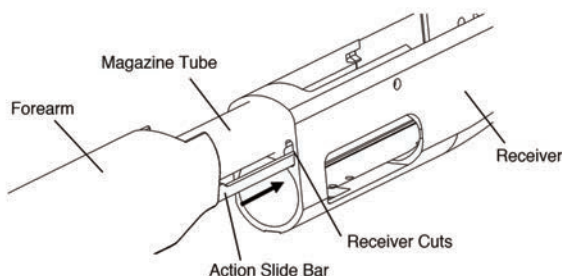

Fig. 15

Assemble the elevator by squeezing the arms together sufficiently to position them in the receiver so that the studs on the elevator fit into the corresponding (1/4" [6.4 mm]) diameter holes in the receiver (Fig. 16).

Pivot the elevator so that the forward portion of the elevator is even with the outside edge of the cavity in the receiver.

Insert the rear of the bolt assembly, with its bolt lock downwards toward the front inside top of the receiver, into the barrel opening of the receiver. Depress the ejector (located in the side of the receiver opposite the ejection port) to allow the bolt assembly to slide fully rearward into the receiver.

The ejector must fit into the corresponding slot in the bolt (Fig. 16).

On left hand models the ejector slot on the bolt as well as the ejector and ejection port on the receiver are on the opposite sides of what is shown below.

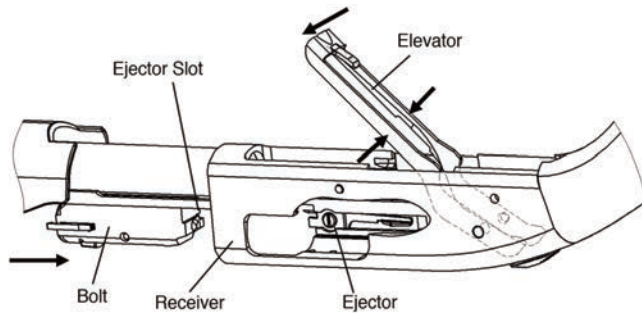

Fig. 16

Position action slide bars so the notch on the bar is even with the cuts on the inside receiver walls (Fig. 17-A).

Push the elevator down until it rests against the bolt. Position the rear of the bolt assembly even with the rear of the clearance cuts in the sides of the receiver (Fig. 17-B).

The bolt slide should be positioned with the slotted side facing up, with notch to the rear (Fig. 17).

Assemble the bolt slide, lowering the front of the bolt slide first. The bolt slide protrusion fits into the corresponding cut on the bottom of the bolt lock, while the two protrusions on each side of the bolt slide fit into each action slide bar slot (Fig. 17-C).

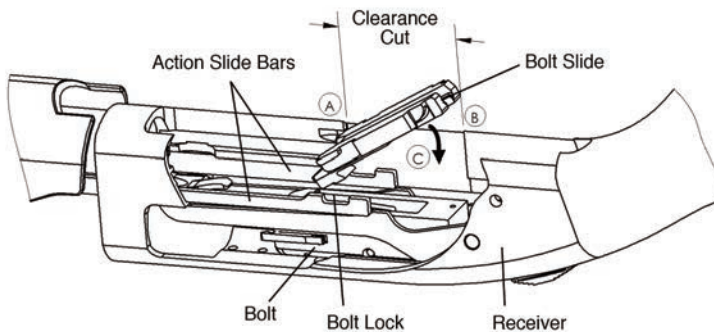

Fig. 17

Position the cartridge stop and cartridge interrupter in their proper places on the inside walls of the receiver (Fig. 18).

On left hand models the positions of the cartridge stop and cartridge interrupter remain in the same as shown but the ejection port is on the opposite side.

The hooks must face inward toward the center of the cavity away from the receiver walls.

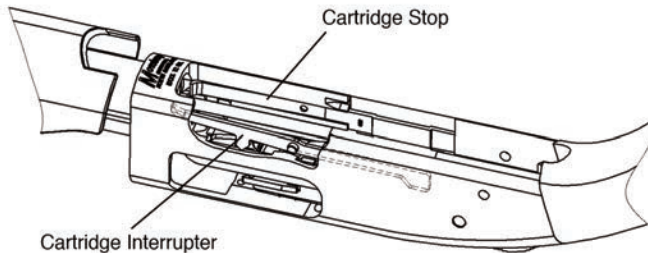

Fig. 18

TRIGGER HOUSING ASSEMBLY INSTALLATION

NOTE: Hammer must be in the fully-cocked position to allow the trigger housing to be inserted in the receiver.

Hold the cartridge stop and cartridge interrupter in place firmly against the receiver walls with one hand and grasp the trigger housing assembly with the other.

Insert the lugs on each side of the front corner of the trigger housing into the slots on each side of the receiver, then ease the rear of the housing assembly down and into position (Fig. 19). **DO NOT FORCE!**

Align the trigger pin hole in the housing assembly with those in the receiver. Insert the trigger housing pin and push in fully until flush with the side of the receiver (Fig. 19).

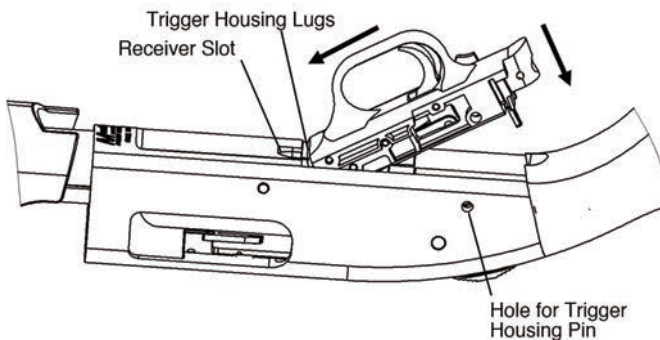

Fig. 19

NOTE: If the trigger housing does not fit into place easily, check that all internal trigger housing pins are flush with the side of the housing and that the cartridge interrupter and cartridge stop are positioned properly.

Reattach the barrel per the instructions in the "Barrel Assembly" section of this manual.



FUNCTION TESTING



AFTER PERFORMING ANY WORK ON YOUR FIREARM SUCH AS CLEANING, DISASSEMBLY OR INSTALLATION OF ANY ACCESSORY, CHECK YOUR FIREARM FOR PROPER FUNCTIONING BEFORE FIRING ANY LIVE AMMUNITION.

- a. Move the safety button fully rearward to the “ON” (SAFE) position and keep muzzle pointed in a safe direction.
- b. Open the action, visually and physically check chamber, elevator and magazine tube to be certain the firearm is unloaded.



KEEP THE MUZZLE POINTED IN A SAFE DIRECTION AT ALL TIMES THROUGHOUT THE FOLLOWING STEPS! FAILURE TO DO SO COULD RESULT IN SERIOUS INJURY OR DEATH IF THE FIREARM HAS NOT BEEN PROPERLY UNLOADED AND FIRES WHILE YOU ARE TESTING ITS FUNCTION!

Depress and hold the action lock lever. Open and close the action several times to check for free movement of the action assembly.

Close the action by moving the forearm fully forward and leave the safety button in the “ON” (SAFE) position. Pull the trigger rearward fully. The hammer should not fall (No Fire).

Remove your finger from the trigger. Move the safety button to the “OFF” (FIRE) position. The hammer should not fall (No Fire).

Leave the safety button in the “OFF” (FIRE) position.

Pull the trigger rearward. The hammer should fall (Fire).

Open the action by moving the forearm fully rearward. Move the safety button fully rearward to the “ON” (SAFE) position.



IF YOUR FIREARM DOES NOT PERFORM AS DESCRIBED IN ANY OF THE ABOVE STEPS, CONTACT THE FACTORY AUTHORIZED PRODUCT SERVICE CENTER IMMEDIATELY. DO NOT ATTEMPT TO USE THE FIREARM.



Firearms are complicated mechanisms. Any modification, alteration, or improper fitting of parts may result in a dangerous malfunction, damage to the firearm and could cause serious injury or death to you or those around you. The firearm’s owner must accept full responsibility for the correct reassembly and functioning of the firearm after any disassembly or replacement of parts.

LIGHTNING PUMP ACTION™ TRIGGER SYSTEM ADJUSTMENTS

Your firearm may be equipped with Mossberg’s revolutionary “Lightning Pump Action” Trigger System (US Patent 8,220,193), an adjustable trigger system that allows you to safely adjust the trigger pull of your firearm from 3 pounds to 6 pounds (approximately). You can adjust the trigger pull by turning the Trigger Pull Adjusting Screw (See Fig. 20 & Fig. 21) clockwise (to increase trigger pull) or counterclockwise (to decrease trigger pull).



BEFORE ANY ATTEMPT IS MADE TO ADJUST YOUR TRIGGER PULL, VISUALLY AND PHYSICALLY INSPECT THE CHAMBER, ELEVATOR AND MAGAZINE TUBE TO MAKE SURE THAT YOUR FIREARM IS UNLOADED. KEEP THE MUZZLE POINTED IN A SAFE DIRECTION AT ALL TIMES!



TO ADJUST YOUR TRIGGER PULL

Remove the Trigger Housing Assembly from the firearm: Using the instructions provided in the “Disassembly” section of this manual, remove the Trigger Housing Assembly from the firearm.

Adjust the Trigger Pull: The Trigger Pull Adjusting Screw is located in the rear of the trigger housing (Fig. 20). Using a 3/32” hex wrench, turn the Trigger Pull Adjusting Screw clockwise to increase the trigger pull, or counterclockwise to decrease the trigger pull (Fig. 21). The Trigger Pull Adjusting Screw incorporates a nylon patch that provides resistance while turning the screw for adjustment, this is normal and to be expected. To set the trigger pull to the minimum setting, back the Trigger Pull Adjusting Screw out until it is approximately flush with the bottom surface of the trigger housing counterbore (Fig. 20). **Do not remove the Trigger Pull Adjusting Screw, spring and follower from the trigger housing. The components may get lost and trigger pull adjustment will not be possible.**

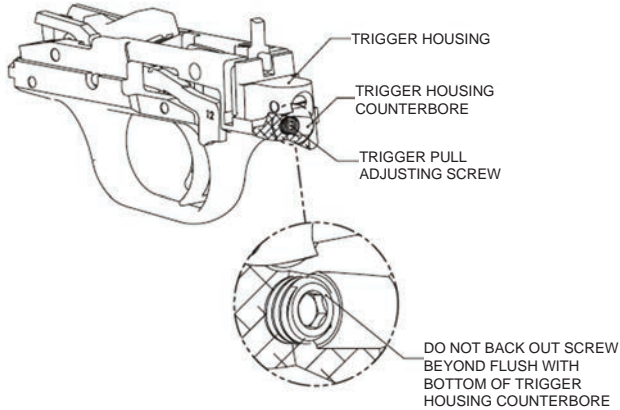

Fig. 20

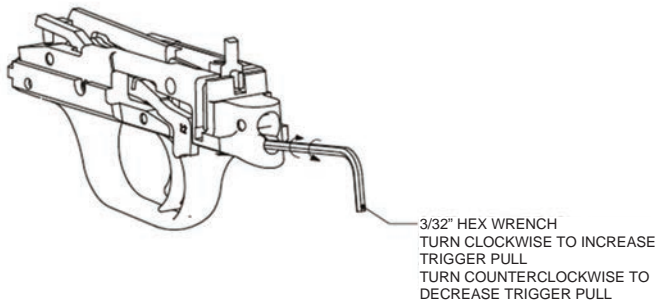

Fig. 21

Reinstall the Trigger Housing Assembly: Using the instructions provided in the “Reassembly” section of this manual, re-install the Trigger Housing Assembly.

Function Test: With your firearm pointed in a safe direction, visually and physically inspect the chamber, elevator and magazine tube to make sure that your firearm is unloaded. Then using the instructions provided in the “Function Testing” section of this manual, perform a complete function test.

If the trigger pull is not to your satisfaction, repeat the above procedure until satisfactory results are obtained.



IF YOUR FIREARM DOES NOT PERFORM AS DESCRIBED IN ANY OF THE PREVIOUS STEPS, CONTACT THE FACTORY AUTHORIZED PRODUCT SERVICE CENTER IMMEDIATELY. DO NOT ATTEMPT TO USE THE FIREARM.



No other trigger adjustments are provided. In order to avoid serious personal injury to you or those around you, no other changes, alterations, or adjustments should be made to the trigger system.



Firearms are complicated mechanisms. Any modification, alteration, or improper fitting of parts may result in a dangerous malfunction, damage to the firearm and could cause serious injury or death to you or those around you. The firearm's owner must accept full responsibility for the correct reassembly and functioning of the firearm after any disassembly or replacement of parts.

SIGHT ADJUSTMENTS



BEFORE MAKING ANY SIGHT ADJUSTMENTS:

- a. Move the safety button fully rearward to the "ON" (SAFE) position and keep muzzle pointed in a safe direction.
- b. Open the action, visually and physically check chamber, elevator and magazine tube to be certain the firearm is unloaded.

RIFLE SIGHT ADJUSTMENTS

Williams Style Rear Sight:

Elevation may be adjusted by loosening the side screw on the rear sight leaf base. This will allow the sight leaf base to be raised or lowered by sliding the base up or down the rear sight ramp. Tighten screw after adjustment.

Windage may be adjusted by loosening the top screw and sliding the sight leaf left or right in the sight leaf base. Tighten screw after adjustment.

Remember: Move the rear sight in the same direction you would like the shot to move. For example, if the point of impact is low and left of the point of aim, move the rear sight upward and to the right.

GHOST RING™ SIGHT ADJUSTMENTS

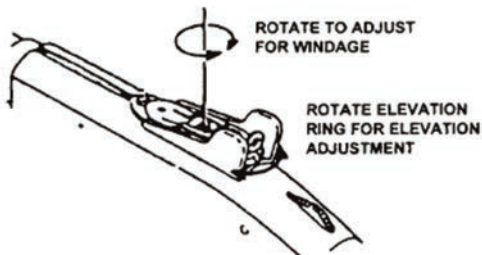

Fig. 22



ACCESSORY BARRELS



Accessory barrels are interchangeable only within specific model, gauge and magazine capacity. Right and left hand model barrels are not interchangeable.

500® Models: HS410™ barrels are not interchangeable with standard 500® .410 bore sporting barrels.

PISTOL GRIP INSTALLATION



BEFORE PERFORMING ANY DISASSEMBLY OR ASSEMBLY PROCEDURE:

- a. Move the safety button fully rearward to the “ON” (SAFE) position and keep muzzle pointed in a safe direction.
- b. Open the action, visually and physically check chamber, elevator and magazine tube to be certain the firearm is unloaded.

To Remove Buttstock:

Loosen the top screw holding the recoil pad on stock. Note: Use cross recess screw driver (“Phillips”-style).

Loosen and remove the bottom recoil pad screw.

Swing the recoil pad around the top screw which will allow access to the stock bolt through the stock bolt hole.

Check stock bolt head configuration. Some models use a slotted head, others use a 1/2 in. hex head.

Loosen and remove stock bolt by turning it counterclockwise. The stock may now be removed from the receiver.

Installation of Pistol Grip:

Align mounting hole in pistol grip with threaded hole in rear of the receiver.

Slip washers on bolt. Insert bolt through pistol grip into hole in receiver. Finger tighten bolt to ensure threads are properly engaged. If you encounter difficulty, unscrew bolt and repeat procedure.

Using hex wrench supplied, tighten bolt snugly.

To install the swivel stud, screw it into the hole on the left hand side of the pistol grip until tight. The swivel stud is self-tapping. Align the swivel stud through-hole to the desired position. Use caution not to over-tighten the swivel stud as this may strip the threads in the pistol grip.

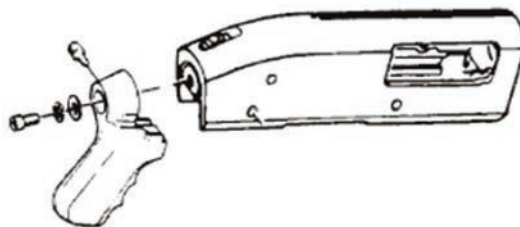

Fig. 23





Upon firing, recoil force will cause the firearm to move rearward and upward. Never hold the firearm at eye level and attempt to sight down the barrel. To avoid possible injury, grip the firearm securely with one hand on the forearm and one hand on the pistol grip. Pistol grip models are designed to be held at waist level when firing.

+4 SHELL HOLDER STOCK



BEFORE CLEANING OR REMOVING THE +4 SHELL HOLDER STOCK:

- a. Move the safety button fully rearward to the "ON" (SAFE) position and keep muzzle pointed in a safe direction.
- b. Open the action, visually and physically check chamber, elevator and magazine tube to be certain the firearm is unloaded.

The stock springs and followers should be removed periodically and the tubes and parts cleaned to remove debris. Do not lubricate these parts.



The recoil pad on the +4 Shell Holder Stock is under spring pressure. Remove shotshells from storage tubes to minimize the spring pressure. Use caution when removing recoil pad screws to prevent injury to yourself or others around you.

Loosen and remove the two recoil pad screws by turning them counterclockwise. Remove the recoil pad, springs and plastic followers. Place on a clean dry surface.

To Reassemble:

Insert one plastic follower into each magazine tube in the stock. Orientate the top follower with "T" on top and the bottom follower with "B" on top (Fig. 24). Be sure the hollow portion of the follower is facing toward the rear of the stock.

Insert one spring in each of the two magazine tubes. The springs will fit inside the cupped end of the followers inserted in the previous step.

Screw the recoil pad screws into the recoil pad until the screw points come through the opposite side about 1/8 of an inch. Place the pad against the springs so that the end of each spring rests against the recessed area on the pad.

Compress the springs into the magazine tubes by pushing the pad flush against the stock. Adjust the pad until you feel the points of the screws fit into the pre-drilled holes in the stock.

While maintaining pressure on the pad, tighten the recoil pad screws securely. Do not overtighten screws.

Check for free movement of the followers by pushing them into the magazine tube with your finger and allowing them to snap back into position under spring pressure.

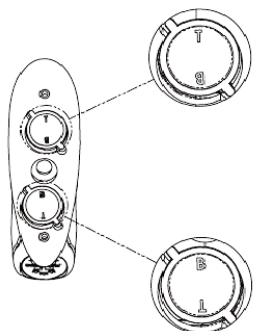

FOLLOWER ORIENTATION DETAIL

TOP FOLLOWER, "T" ON TOP
BOTTOM FOLLOWER, "B" ON TOP

Fig. 24



6-POSITION ADJUSTABLE TACTICAL STOCK

The Model 500 Tactical Model comes equipped with a 6-Position Adjustable Tactical Synthetic Stock with a detachable comb and recoil pad.

TO ADJUST 6-POSITION BUTTSTOCK



Before making any stock adjustments, move the safety button fully rearward to the "ON" (SAFE) position and visually and physically check the chamber, elevator, and magazine tube to be certain the firearm is unloaded. Also, be sure to keep the action open and the muzzle pointed in a safe direction.

The adjustable tactical stock (Fig. 25) has 6 positions to adjust length of pull. To adjust length of pull, squeeze latch and slide stock in or out to the desired position. Release latch and push inward on rear of stock until the stock locks into place. Tap or push on rear of stock to verify stock is locked into place and perform a function test per instructions in the "FUNCTION TESTING" section of this owner's manual.

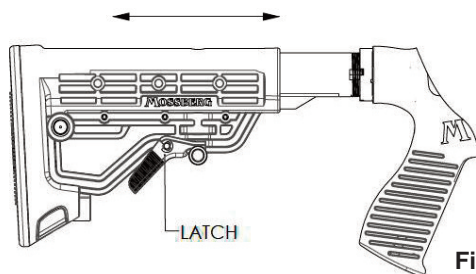

Fig. 25



To avoid damage to the stock and to prevent possible personal injury, before firing live ammunition verify the stock is locked into place by tapping on rear of stock and performing a function test per instructions in the "FUNCTION TESTING" section of this owner's manual.

COMB REMOVAL AND ATTACHMENT



BEFORE PERFORMING ANY WORK ON YOUR FIREARM SUCH AS DISASSEMBLY OR INSTALLATION OF AN ACCESSORY:

- a. Move the safety button fully rearward to the "ON" (SAFE) position and keep the muzzle pointed in a safe direction.
- b. Open the action and visually and physically inspect the chamber, elevator and magazine tube to be certain the firearm is unloaded.

To remove the comb, hold the firearm firmly with one hand, grasp the front edge of the comb with the other hand and pull up (Fig. 26).



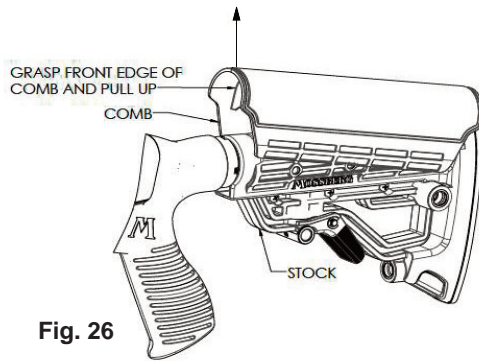

Fig. 26

To attach the comb on the stock, align the vertical ribs on the comb with the vertical ribs on the stock (Fig. 27). Push down on the comb until the locking buttons on the comb (3 per side) snap into mating locking rings on the stock (Figs. 27 and 28). Push forward and back on the comb and try to rotate. It should remain firmly in place.



Failure to properly engage the locking buttons with the locking rings will cause the comb to be attached incorrectly, allowing the comb to shift forward and backward when firing the firearm. To avoid damage to the stock and prevent possible personal injury, make sure the ribs are aligned and the comb locks into place securely before attempting to use your firearm.

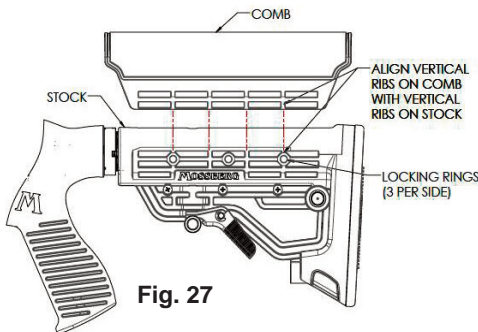

Fig. 27

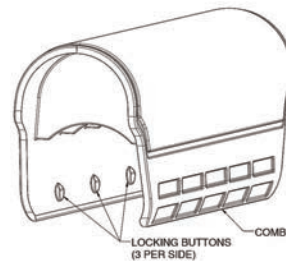

Fig. 28

SHELL HOLDER REMOVAL AND ATTACHMENT

The Model 500 Tactical Model comes equipped with a 6-Position Adjustable Tactical Synthetic Stock with a detachable Shell Holder.



BEFORE PERFORMING ANY WORK ON YOUR FIREARM SUCH AS DISASSEMBLY OR INSTALLATION OF AN ACCESSORY:

- a. Move the safety button fully rearward to the "ON" (SAFE) position and keep the muzzle pointed in a safe direction.
- b. Open the action and visually and physically inspect the chamber, elevator and magazine tube to be certain the firearm is unloaded.

Using a phillips head screwdriver remove the (3) screws on the stock and pull the shell holder off the stock (Fig. 29 and 30).

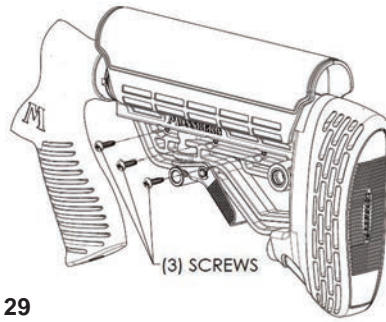

Fig. 29

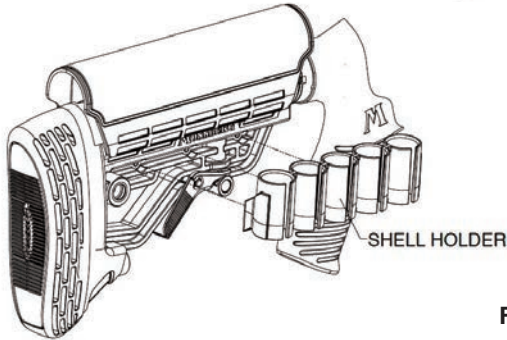

Fig. 30

To attach the shell holder on the stock, engage the three bosses (Fig. 31a) on the shell holder with the three mating recessed holes in the stock (Fig. 31). This will align the three screw holes in the shell holder with the through holes in the stock. Holding the shell holder against the stock, screw the (3) screws into the shell holder to hold it in place. Torque the screws to 12 in lbs (Figs. 31 and 32). When the shell holder is attached correctly it will not move. The shell holder is designed to be used for a left or right handed shooter. It can be attached to either side of the stock.

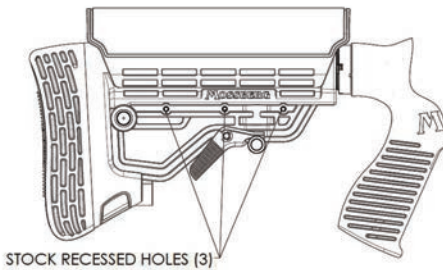

Fig. 31

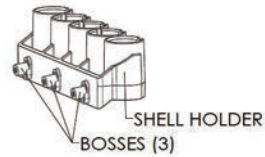

Fig. 31a

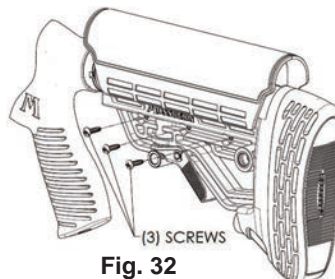
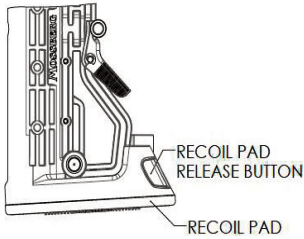
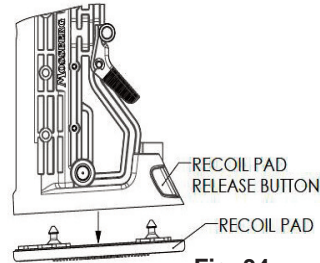

Fig. 32

TO REMOVE RECOIL PAD

Before making any recoil pad changes, move the safety button fully rearward to the "ON" (SAFE) position and visually and physically check the chamber, elevator, and magazine tube to be certain the firearm is unloaded. Also, be sure to keep the action open and the muzzle pointed in a safe direction.

To remove recoil pad, fully depress the recoil pad release button (Fig. 33) while pulling the recoil pad away from the buttstock until it comes free (Fig. 34).

**Fig. 33****Fig. 34****TO ATTACH RECOIL PAD**

Before making any recoil pad changes, move the safety button fully rearward to the "ON" (SAFE) position and visually and physically check the chamber, elevator, and magazine tube to be certain the firearm is unloaded. Also, be sure to keep the action open and the muzzle pointed in a safe direction.

Identify the bosses on the recoil pad (Fig. 35) and the pear-shaped holes in the recoil pad release lever (Fig. 36).

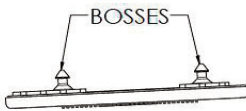
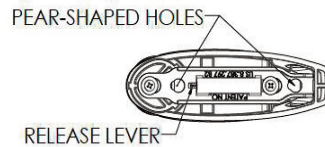
**Fig. 35****Fig. 36**

Push bosses on recoil pad through the pear-shaped holes in recoil pad release lever (Figs. 37 & 38). Push the pad towards the top of the stock and in until the release lever audibly clicks into place. Tug and twist the pad to ensure it is properly seated and perform a function test per instructions in the "FUNCTION TESTING" section of this owner's manual.

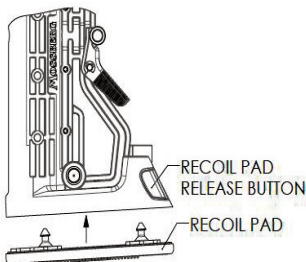
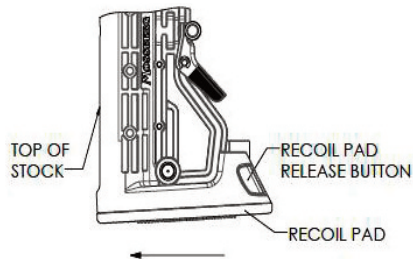
**Fig. 37****Fig. 38**



HEAT SHIELD



BEFORE PERFORMING ANY DISASSEMBLY OR ASSEMBLY PROCEDURE:

- a. Move the safety button fully rearward to the “ON” (SAFE) position and keep muzzle pointed in a safe direction.
- b. Open the action, visually and physically check chamber, elevator and magazine tube to be certain the firearm is unloaded.

NOTE: Ghost Ring sight models come from the factory with the heatshield installed. It is not recommended that the heatshield be removed.

Heat Shield Disassembly (Bead Sight):

Follow barrel removal procedures as described in the “Disassembly” section of this manual.

Carefully remove front sight by turning it counterclockwise. Take precautions to ensure you do not damage the barrel finish or front sight.

Using a 7/64” hex key wrench and a 5/16” open end or box wrench, remove the clamp screws holding the heat shield in place.

Slide the heat shield off the barrel from the muzzle end.

Reinstall front sight.

Follow barrel assembly procedures as described in the “Reassembly” section of this manual.

Heat Shield Assembly (Bead Sight):

Follow barrel removal procedures as described in the “Disassembly” section of this manual.

Carefully remove front sight by turning it counterclockwise. Take precautions to insure you do not damage the barrel finish or front sight.

Slide heat shield onto barrel from the muzzle end. The large ring on heat shield must be positioned towards the rear of barrel.

With the heat shield on the barrel, use a small padded “C” clamp or a vise, to close the forward clamp of the heat shield.

Position the plastic spacer between the forward clamp. Insert the two screws and start the two hex nuts on the screws using a 7/64” hex key wrench and a 5/16” open end or box wrench. DO NOT FULLY TIGHTEN THE TWO SCREWS YET.

Follow barrel assembly procedures as described in the “Reassembly” section of this manual.



When securing heat shield, the barrel must be attached to the shotgun. Barrels with heat shield secured are not interchangeable without proper refitting of the heat shield to firearm as described in the above procedure.

Make sure the takedown screw or magazine cap is secure and the barrel is fully seated before proceeding to the next step.

Position heat shield so that the rear (large ring) butts up against the front of the receiver.





Using a 7/64" hex key wrench and a 5/16" open end or box wrench, tighten the clamp screws to securely hold the heat shield in place. **DO NOT OVERTIGHTEN THE SCREWS.**

Reinstall front sight.



Whenever the heat shield barrel is installed on the shotgun, repeat the above steps to ensure that the shield is not preventing the barrel from being seated fully.

DUAL-COMB® TROPHY STOCK



BEFORE PERFORMING ANY DISASSEMBLY OR ASSEMBLY PROCEDURE:

- a. Move the safety button fully rearward to the "ON" (SAFE) position and keep muzzle pointed in a safe direction.
- b. Open the action, visually and physically check chamber, elevator and magazine tube to be certain the firearm is unloaded.

To Change Removable Combs:

Using a 3/16 inch hex key wrench (supplied) unscrew and remove the comb retaining screw found at the top center of the removable comb.

Place the desired comb into position. Insert the comb retaining screw and snug-tighten. Do not overtighten as this will damage the internal assembly components.

ACCU-CHOKE™ AND ACCU-MAG CHOKE™ TUBES



BEFORE REMOVING OR INSTALLING ANY CHOKE TUBE:

- a. Move the safety button fully rearward to the "ON" (SAFE) position and keep muzzle pointed in a safe direction.
- b. Open the action, visually and physically check chamber, elevator and magazine tube to be certain the firearm is unloaded.



Do not use bent or deformed choke tubes as these may result in tube or barrel damage upon firing which may cause serious personal injury. Inspect choke tubes periodically to insure they are properly installed and in good condition. Pay special attention to the threaded end of the choke tube to be certain it is not deformed or dented.



Never fire this firearm without a choke tube properly installed. Failure to do so will damage the precision threads on the inside of the barrel. Firing this firearm with loose choke tubes may lead to damage to the choke tube and barrel, as well as serious personal injury.

CARE & CLEANING: The precision threads on your choke tube should be kept clean and lightly oiled at all times.



During cleaning of the barrel, be certain a choke tube is properly installed. This will avoid residue build-up on threads.

Extra-Full choke tubes are not recommended for use with buckshot or slugs.

The "Improved Cylinder" choke tube will usually produce the best accuracy with most slugs.

ACCU-CHOKE™ TUBES

ACCU-CHOKE™ TUBES are designed for use with LEAD or STEEL shot. Each durable choke tube is clearly marked, as a guide, with the pattern it will produce.



Do not shoot steel shot through the X-Full and XX-Full Turkey Tubes as barrel damage and/or personal injury may result.

TO REMOVE CHOKE TUBE: Loosen with choke wrench provided, turning it counterclockwise. When the choke tube is loosened, remove it completely with your fingers. Place choke tube on a clean, dry surface.

TO INSTALL CHOKE TUBE: Screw the tube clockwise into barrel by hand and then tighten the tube until snug with the choke wrench. Flush fitting tubes fit completely inside the barrel when properly installed. Do not use excessive force when installing.



Tube tightness should be checked periodically.

ACCU-CHOKE™ TUBES

GAUGE	ITEM #	LEAD SHOT PATTERN*	Extended Or Flush Fitting
12	95235	Skeet	Flush
12	95200	Improved Cylinder	Flush
12	95170	Improved Cylinder	Extended, Ported
12	95195	Modified	Flush
12	95180	Modified	Extended, Ported
12	95245	Improved Modified	Flush
12	95190	Full	Flush
12	95240	X-Full	Flush
12	95268	XX-Full Turkey (Lead Only)	Extended, Ported
12	95267	XX-Full Turkey (Lead Only)	Extended
20	95225	Improved Cylinder	Flush
20	95220	Modified	Flush
20	95215	Full	Flush
20	95230	X-Full Turkey (Lead Only)	Flush
20	95231	X-Full Turkey (Lead Only)	Extended, Ported

* Lead, steel, and other non-toxic shot patterns will vary substantially depending on shotshell length, shot size, brand of ammunition, and the individual barrel. The shooter is urged to conduct pattern tests before field use.



X-Full Turkey and XX-Full Turkey tubes are designed for lead pellet shot loads only. We specifically disclaim any responsibility for damage or injury resulting from firing slugs (single projectile ammunition) or steel shot through X-Full and XX-Full Turkey Tubes.

ACCU-MAG™ CHOKE TUBES (835 MODELS ONLY)

ACCU-MAG™ choke tubes are internal, flush fitting or extended choke tubes designed for use with LEAD or STEEL shot. Each durable tube is clearly marked, as a guide, with the lead and the steel shot pattern it will produce.



Do not use steel shot through the XX-Full Turkey or the Ulti-Full Turkey Tubes as barrel damage and/or personal injury may result.

TO REMOVE CHOKE TUBE: Loosen with choke wrench provided, turning it counterclockwise. When the choke tube is loosened, remove it completely with your fingers. Place choke tube on a clean, dry surface.

TO INSTALL CHOKE TUBE: Screw the tube clockwise into barrel by hand and then tighten the tube until snug with the choke wrench. Flush fitting tubes fit completely inside the barrel when properly installed. Do not use excessive force when installing.



Tube tightness should be checked periodically.

ACCU-MAG™ CHOKE TUBES

ITEM #	LEAD SHOT PATTERN*	STEEL SHOT PATTERN*	Extended Or Flush Fitting
95256	Skeet	Skeet	Flush
95252	Improved Cylinder	Mod. T & F	Flush
95270	Full	Mod. T & F	Ext. Port.
95253	Modified	Mod. #2 and BB	Flush
95280	Modified	Mod. #2 and BB	Ext. Port.
95254	Full	Full #2 and BB	Flush
95290	Improved Cylinder	Full #2 and BB	Ext. Port.
95255	X-Full (Steel)	X-Full (Steel)	Flush
95251	XX-Full Turkey (Lead Only)	Do Not Use	Flush
95258	Ulti-Full Turkey	Do Not Use	Ext. Port.
95257	Ulti-Full Turkey	Do Not Use	Ext.

* Lead, steel, and other non-toxic shot patterns will vary substantially depending on shotshell length, shot size, brand of ammunition, and the individual barrel. The shooter is urged to conduct pattern tests before field use.



SLUGS: Overbored 835® Model Accu-Mag™ barrels are designed for lead or steel pellet shot loads only. We specifically disclaim any responsibility for damage or injury resulting from firing slugs (single projectile ammunition) through overbored barrels. Use only 835® Model barrels designed specifically for slug shooting.



ACCU-MAG™ ULTI-FULL™ TURKEY TUBE

The NATIONAL WILD TURKEY FEDERATION has determined that the average distance at which turkeys are most effectively taken, under average environmental conditions and surroundings is 30 yards.

Subsequently, Mossberg® designed and manufactures highly specialized choke tubes for #4 or #6 lead shot to yield a high shot concentration and pellet count in a 20 inch circle at 30 yards. Shot patterns at distances greater than 30 yards will be less dense.

These special purpose “Turkey Tubes” are specifically designed for use with lead shot loads only



Do not shoot steel shot through Extra or Ulti-Full turkey tubes as it may result in barrel damage and/or personal injury may result.

Test results are averages and individual shotgun performance may vary. Mossberg recommends pattern testing with several brands of ammunition and at various distances to familiarize yourself with your shotgun’s performance.

MUZZLELOADER CONVERSION BARREL



Do not attempt to assemble, load or use the Muzzleloading barrel until you thoroughly read and understand the information contained in this shotgun Owner’s Manual and the contents of the Muzzleloading Barrel Owner’s Manual.



You have a responsibility to obtain proper training on how to use and maintain your firearm. Certified and reputable instructions are offered by the National Rifle Association, The National Muzzleloading Rifle Association, Black Powder Association as well as state and local organizations. Seek guidance from an instructor who is qualified by one of these organizations.



Be certain the shotgun Owner’s Manual and the Muzzleloading Barrel Owner’s Manual are available for reference and supplied with the shotgun and/or the Muzzleloading Barrel if transferred to another party.



If either manual is lost or misplaced, request a free replacement copy from the Product Service Center or download from Mossberg.com.

Consult your local Department of Natural Resources and Wildlife for guidelines to confirm that this muzzleloading product will conform to local seasonal and legal requirements.



SERVICE INSTRUCTIONS

Should your firearm or any component of your firearm require service, ship your entire firearm (please do not send components only), via your chosen carrier, postage paid (we do not accept C.O.D. shipments), following these instructions:

Repairs in the U.S.

For faster repair service, please start the process by filling out our Service Request Form online at <http://www.mossberg.com/service> prior to shipping your firearm.



- **Make absolutely certain your firearm is unloaded.**
- **Do not send ammunition with your firearm.**
- Remove all accessories from your firearm such as scopes, slings, scope mounts, etc.
- Ship your firearm in a suitable container, packaging it securely to prevent parts from shifting and/or damage during shipping.
- Include a note with a clear description of the service you wish us to perform, your complete return shipping address (no P.O. boxes please), your daytime telephone number and your e-mail address (if available).
- It is advisable to place your correspondence inside your shipping container when shipping.

SHIPPING ADDRESS

Mossberg Product Service Center
1001 Industrial Blvd.
Eagle Pass, TX 78852

If you have any service related questions, please contact the Product Service Center at (800) 363-3555 or service@mossberg.com

TO ORDER PARTS

To order parts from the Product Service Center, you can fax, phone, email, or mail your order to one of the below numbers/addresses.

Fax Number: (203) 230-5420

Phone Number: (800) 363-3555

E-mail Address: service@mossberg.com

Mailing Address: Mossberg Product Service Center
1001 Industrial Blvd.
Eagle Pass, TX 78852
Attn: Order Department

Please provide your name, address, city, state, zip, your daytime phone number and e-mail (if available). The Product Service Center will need the Model Number, Serial Number, Gauge/Caliber, Finish, Item Number, and Part Name. There is a \$7.50 (U.S.) minimum parts order charge. Most major credit cards, money orders, and bank drafts are accepted.

Service outside of the U.S.A.

For Mossberg firearm parts and service requirements outside of the United States, customers are requested to contact the closest Mossberg stocking dealer/distributor.

MOSSBERG® WARRANTY
MOSSBERG 500®, 505™, 510™, 535™, 590® AND 835®
TEN (10) YEAR LIMITED WARRANTY

Limited Warranty: O.F. Mossberg & Sons, Inc. ("Mossberg") warrants to you, the original retail purchaser of a new Mossberg 500®, 505™, 510™, 535™, 590® AND 835® Shotgun (the "Mossberg firearm"), that the Mossberg firearm will be free of defects in material or manufacture for a period of ten (10) years from the date of your purchase of the new Mossberg firearm (the "Warranty Period") in the United States or Canada. This is the only express warranty on the Mossberg firearm. MOSSBERG MAKES NO OTHER WARRANTIES OF ANY KIND OR CONDITIONS, INCLUDING, BUT NOT LIMITED TO ANY IMPLIED WARRANTY OF MERCHANTABILITY OR FITNESS FOR A PARTICULAR PURPOSE. This Limited Warranty gives you specific legal rights, and you may have other rights that vary from State to State.

Purchaser's Remedy: During the Warranty Period, Mossberg will, at its sole option, (1) repair the Mossberg firearm or any part thereof that, upon examination and testing by Mossberg, does not conform to the Limited Warranty without charge to you for parts or labor, or (2) replace the Mossberg firearm with a new or similar model. THIS REMEDY SHALL BE YOUR EXCLUSIVE AND SOLE REMEDY FOR ANY BREACH OF WARRANTY. MOSSBERG SHALL NOT BE RESPONSIBLE FOR ANY OTHER EXPENSES, LOSSES OR INCONVENIENCE THAT YOU MAY SUSTAIN AS A RESULT OF THE PURCHASE, USE, MALFUNCTION OR DEFECTIVE CONDITION OF THE MOSSBERG FIREARM. Mossberg reserves the right to inspect, examine and/or test the Mossberg firearm to assess any claim made under the Limited Warranty.

EXCLUSIONS: THIS WARRANTY DOES NOT COVER THE COSMETIC APPEARANCE OF THE MOSSBERG FIREARM OR ANY DAMAGE CAUSED BY:

- (1) NORMAL WEAR AND TEAR;
- (2) FAILURE TO PERFORM PROPER CARE AND MAINTENANCE;
- (3) ACCIDENTS, ABUSE OR NEGLIGENCE;
- (4) BARREL OR BORE OBSTRUCTIONS;
- (5) FAILURE TO FOLLOW THE INSTRUCTIONS AND WARNINGS THAT ACCOMPANY THE MOSSBERG FIREARM; OR
- (6) THE USE OF DEFECTIVE, NON-SAAMI STANDARD, REMANUFACTURED, HANDLOADED, AND/OR RELOADED AMMUNITION.

IN ADDITION, ANY UNAUTHORIZED REPAIRS, ALTERATIONS OR MODIFICATIONS TO THE MOSSBERG FIREARM WILL AUTOMATICALLY VOID THE LIMITED WARRANTY.

LIMITATION OF DAMAGES: EXCEPT WHERE PROHIBITED BY LAW, MOSSBERG WILL NOT BE LIABLE FOR ANY LOSS OR DAMAGE WHATSOEVER ARISING FROM THE USE OF THIS MOSSBERG FIREARM, WHETHER DIRECT, INDIRECT, SPECIAL, INCIDENTAL, CONSEQUENTIAL OR PUNITIVE, REGARDLESS OF THE LEGAL THEORY ASSERTED, INCLUDING CONTRACT, WARRANTY, NEGLIGENCE, OR STRICT LIABILITY. SOME JURISDICTIONS DO NOT ALLOW LIMITATIONS ON HOW LONG AN IMPLIED WARRANTY LASTS, OR THE EXCLUSION OF INCIDENTAL OR CONSEQUENTIAL DAMAGES, SO THE ABOVE LIMITATIONS MAY NOT APPLY TO YOU.

Warranty Service: To obtain service under this Limited Warranty, you must follow the instructions found in the "Service Instructions" section of the Owner's Manual and return the Mossberg firearm to the authorized Product Service Center. You are responsible for all shipping costs to the Product Service Center. Mossberg will not accept COD shipments of any Mossberg firearm for service. After repair or replacement, the Mossberg firearm or a similar model will be returned to you, return postage paid by Mossberg. If we replace the Mossberg firearm, we will keep the firearm that you returned to Mossberg.

Modification of Warranty: No agent, representative, distributor, or authorized dealer of Mossberg firearms has any authority to modify the terms or conditions of the Limited Warranty in any way. The Limited Warranty may only be modified in writing by an authorized officer of Mossberg.

THIS LIMITED WARRANTY IS EFFECTIVE JANUARY 1, 2003.

PARTS LIST

ITEM NO.	DESCRIPTION	ITEM NO.	DESCRIPTION
1.	Barrel Assembly	27.	Magazine tube
2.	Mid-point bead	28.	Action slide assembly
3.	Front Sight	29.	Forearm
4.	Takedown screw (model 500®/ 505™/535™)	30.	Action slide tube nut
5.	Choke tube	31.	Rifled barrel
* 6.	Receiver	32.	Front sight assembly
7.	Scope mount dummy screws	33.	Rear rifle sight assembly
8.	Ejector	34.	Magazine cap (model 590®/835®)
9.	Ejector Screw	35.	Retaining washer
10.	Elevator	36.	Front swivel stud
11.	Cartridge stop	37.	Heat shield
12.	Cartridge interrupter	38.	Heat shield spacer
* 13.	Bolt assembly	39.	Heat shield screw/nuts
* 14.	Bolt Slide	40.	+4 Shell Holder Stock
* 15.	Trigger housing assembly	41.	+4 Shell Holder recoil pad
16.	Trigger housing pin	42.	+4 Shell Holder recoil pad screws
17.	Stock	43.	+4 Shell Holder Stock bolt
18.	Recoil Pad	44.	Lock washer
19.	Spacer	45.	Flat washer
20.	Recoil pad screw	46.	Stock swivel Q.D. post
21.	Stock bolt	47.	+4 Shell Holder followers
22.	Lock washer	48.	+4 Shell Holder springs
23.	Ejector follower	** 49.	Recoil pad, adjustable stock
24.	Magazine spring	50.	6-Position adjustable stock
25.	Limiting plug	51.	Pistol grip
26.	Retaining 'O' ring		

* Restricted Item

** See exploded view for recoil pad sizes.

EXPLODED VIEW

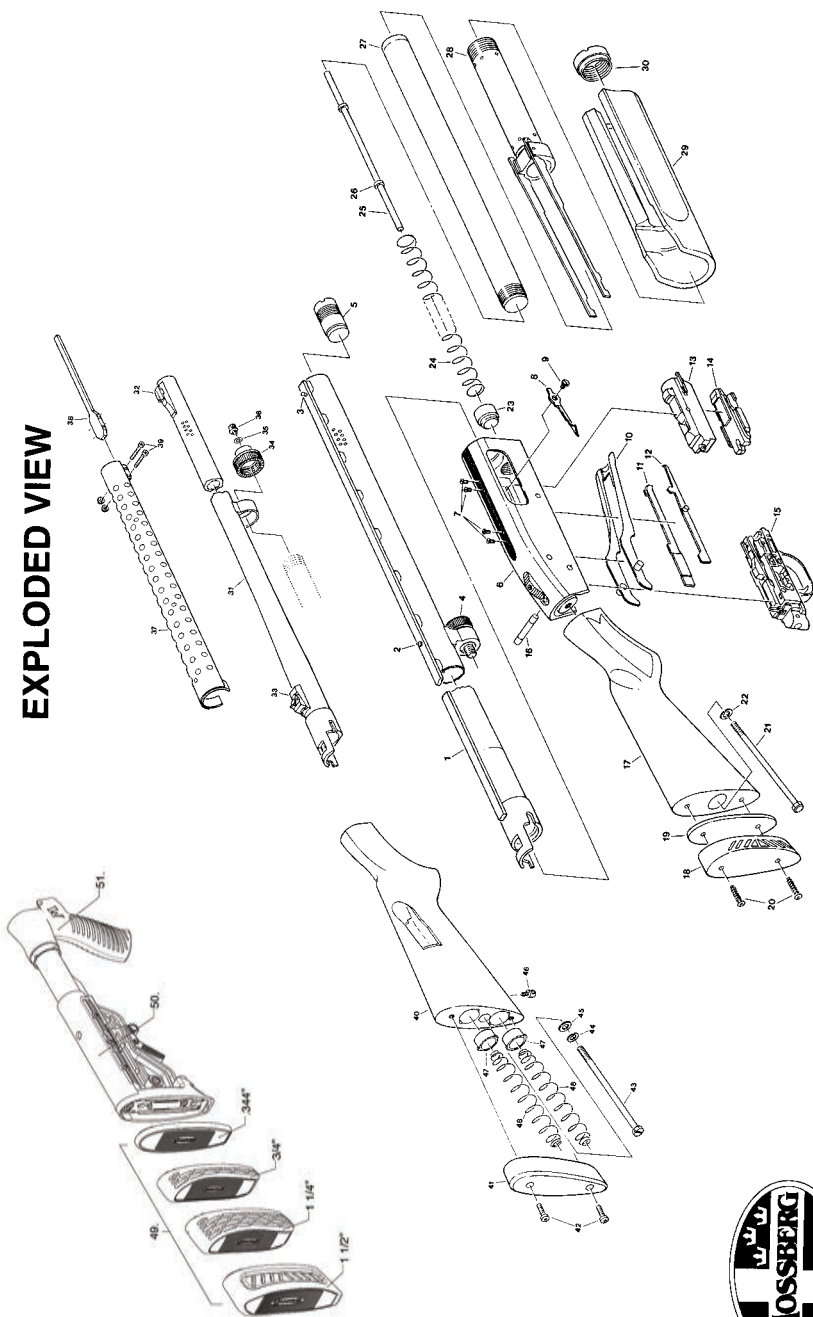

NOTES

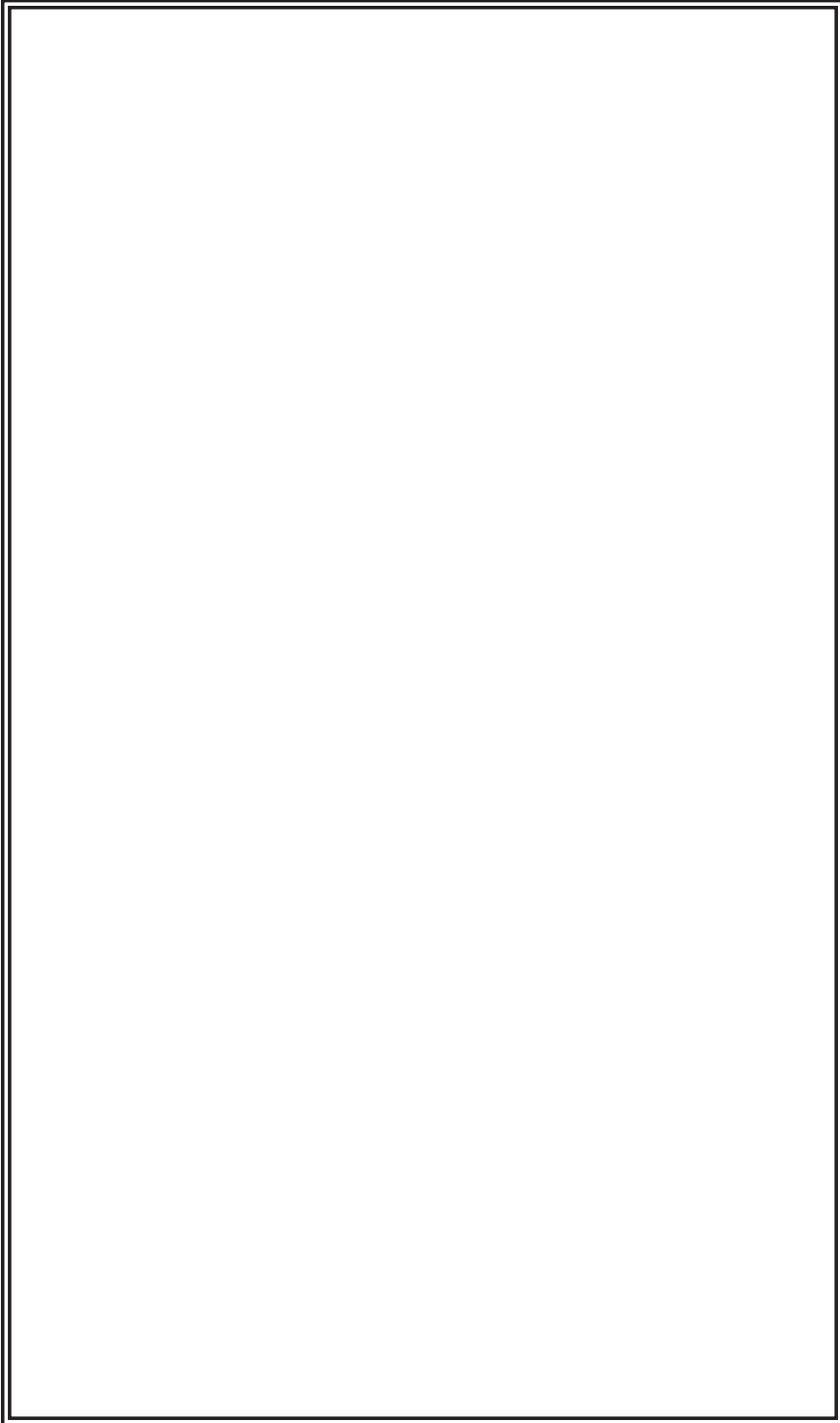

NOTES

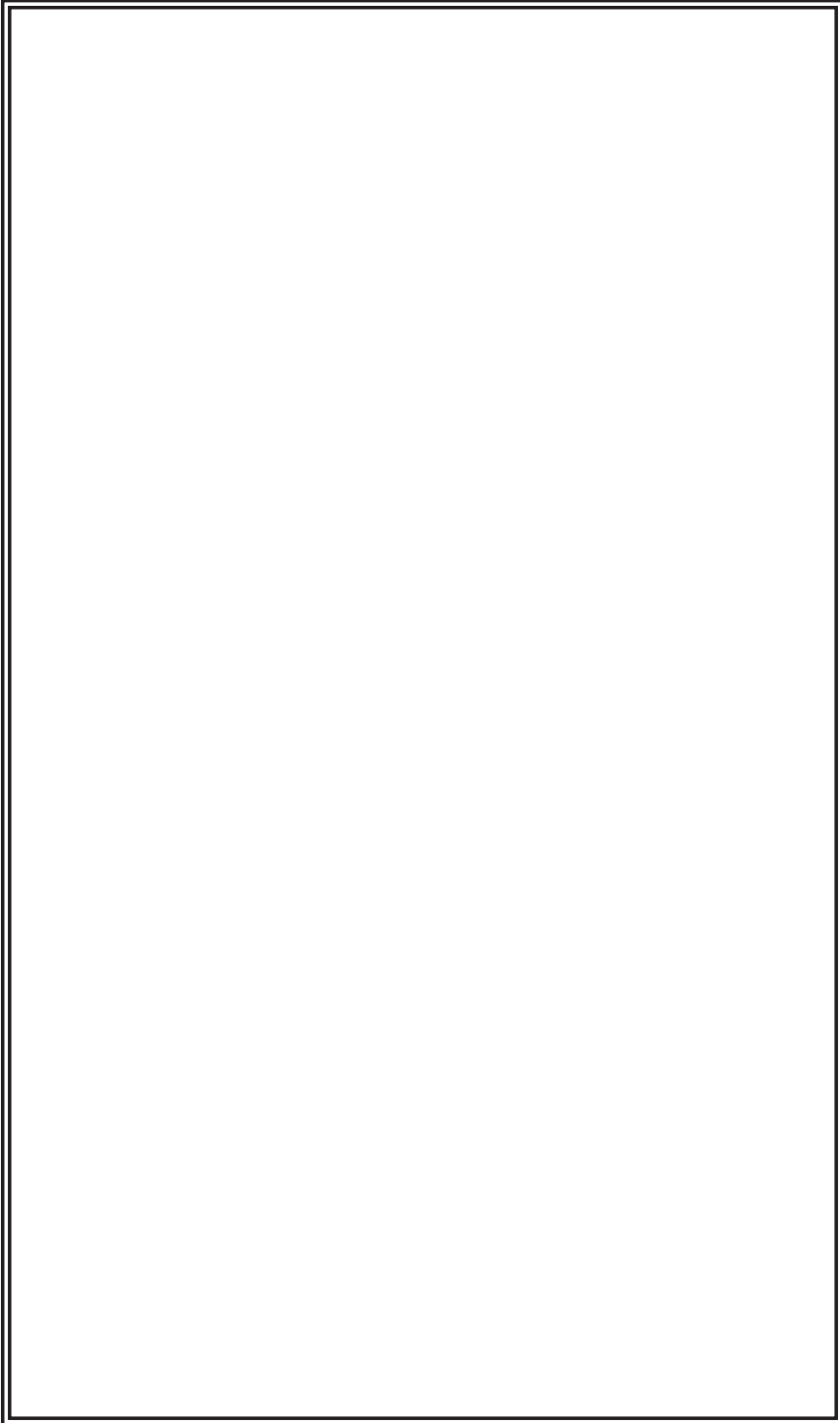

FIREARMS SAFETY DEPENDS ON YOU. MAKE NO MISTAKE ABOUT IT!

From the time an individual picks up a firearm, that individual shooter becomes a part of a system over which he or she has complete control. He or she is the only part of the system that can make a gun safe – or unsafe. Hunting and target shooting are among the safest of all sports. This booklet is intended to make them even safer – by re-emphasizing and reaffirming the basics of safe gun handling and storage and by reminding each individual shooter that he or she is the key to firearms safety. You can help meet this responsibility by enrolling in hunter safety or shooting safety courses. You must constantly stress safety when handling firearms, especially to children and non-shooters. Newcomers in particular must be closely supervised when handling firearms with which they may not be acquainted. Don't be timid when it comes to gun safety. If you observe anyone violating any safety precautions, you have an obligation to suggest safer handling practices, such as those in this booklet. Please read these rules carefully and follow the safety procedures outlined. Firearms safety is up to you. Make no mistake about it.

- 1. ALWAYS KEEP THE MUZZLE POINTED IN A SAFE DIRECTION**
- 2. FIREARMS SHOULD BE UNLOADED WHEN NOT ACTUALLY IN USE**
- 3. DON'T RELY ON YOUR GUN'S "SAFETY"**
- 4. BE SURE OF YOUR TARGET AND WHAT'S BEYOND IT**
- 5. USE CORRECT AMMUNITION**
- 6. IF YOUR GUN FAILS TO FIRE WHEN THE TRIGGER IS PULLED, HANDLE WITH CARE**
- 7. ALWAYS WEAR EYE AND EAR PROTECTION WHEN SHOOTING**
- 8. BE SURE THE BARREL IS CLEAR OF OBSTRUCTIONS BEFORE SHOOTING**
- 9. DO NOT ALTER OR MODIFY YOUR GUN, AND HAVE GUNS SERVICED REGULARLY**
- 10. LEARN THE MECHANICAL AND HANDLING CHARACTERISTICS OF THE FIREARM YOU ARE USING**

*Courtesy of
Sporting Arms and Ammunition Manufacturers' Institute, Inc.*